

DATA SHEET

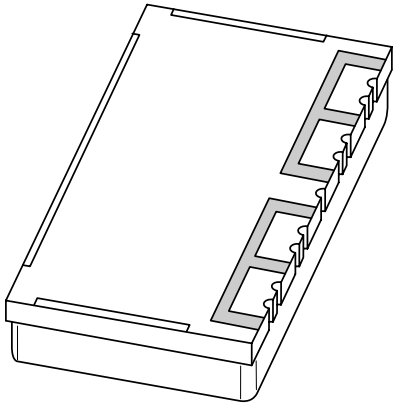

BGY120A; BGY120B UHF amplifier modules

Objective specification

1997 Nov 11

UHF amplifier modules

BGY120A; BGY120B

FEATURES

- Single 3.5 V nominal supply voltage
- 1 W output power
- Easy control of output power by DC voltage
- Very high efficiency (typ. 60%)
- Silicon bipolar technology
- Standby current less than 10 μ A.

APPLICATIONS

- Hand-held transmitting equipment operating in the 824 to 849 MHz and 872 to 905 MHz frequency ranges.

DESCRIPTION

The BGY120A and BGY120B are two-stage UHF amplifier modules in a SOT482B package with plastic cover. Each module consists of two NPN silicon planar transistor dies mounted together with a matching and bias circuit components on a metallized ceramic substrate. These modules produce an output power of 1 W into a load of 50 Ω with an RF drive power of 5 mW.

PINNING - SOT482B

PIN	DESCRIPTION
1	RF input
2	V_C
3	V_S
4	RF output
5	flange connected to ground

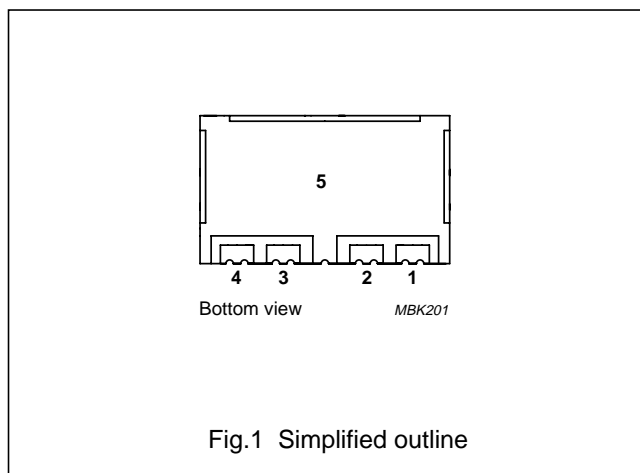

QUICK REFERENCE DATA

RF performance at $T_{mb} = 25$ °C.

TYPE	MODE OF OPERATION	f (MHz)	V_S (V)	P_L (W)	G_p (dB)	η (%)	$Z_S; Z_L$ (Ω)
BGY120A	CW	824 to 849	3.5	1	≥ 23	typ. 60	50
BGY120B	CW	872 to 905	3.5	1	≥ 23	typ. 60	50

UHF amplifier modules

BGY120A; BGY120B

LIMITING VALUES

In accordance with the Absolute Maximum Rating System (IEC 134).

SYMBOL	PARAMETER	MIN.	MAX.	UNIT
V_S	DC supply voltage	–	5	V
V_C	DC control voltage	–	2.9	V
P_D	input drive power	–	10	mW
P_L	load power	–	1.4	W
T_{stg}	storage temperature	–40	+100	°C
T_{mb}	operating mounting-base temperature	–30	+100	°C

CHARACTERISTICS $Z_S = Z_L = 50 \Omega$; $P_D = 5 \text{ mW}$; $V_S = 3.5 \text{ V}$; $V_C \leq 2.5 \text{ V}$; $T_{mb} = 25 \text{ °C}$; unless otherwise specified.

SYMBOL	PARAMETER	CONDITIONS	MIN.	TYP.	MAX.	UNIT
f	frequency range					
	BGY120A		824	–	849	MHz
	BGY120B		872	–	905	MHz
I_Q	total leakage current	$V_C = 0.3 \text{ V}$; $P_D < -60 \text{ dBm}$	–	–	10	μA
I_C	control current		–	–	10	mA
P_L	load power	$V_C = 2.5 \text{ V}$	1	–	–	W
		$V_S = 3.2 \text{ V}$; $T_{mb} = 85 \text{ °C}$	0.71	–	–	W
G_p	power gain	adjust V_C for $P_L = 1 \text{ W}$	23	–	–	dB
η	efficiency	$V_S = 3.2 \text{ V}$; adjust V_C for $P_L = 0.9 \text{ W}$	55	60	–	%
H_2	second harmonic	adjust V_C for $P_L = 0.9 \text{ W}$	–	–	–35	dBc
H_3	third harmonic	adjust V_C for $P_L = 0.9 \text{ W}$	–	–	–40	dBc
$V_{SWR_{in}}$	input VSWR	adjust V_C for $P_L = 0.9 \text{ W}$	–	–	2 : 1	
		$V_C \leq 0.5 \text{ V}$	–	–	4 : 1	
	stability	$P_L \leq 1.4 \text{ W}$; $V_C = 0 \text{ to } 2.9 \text{ V}$; $V_S = 2.8 \text{ to } 5 \text{ V}$; $P_D = 4 \text{ to } 10 \text{ dBm}$; $V_{SWR} \leq 6 : 1$ through all phases	–	–	–60	dBc
	isolation	$V_C \leq 0.5 \text{ V}$	–	–40	–	dBm
P_n	noise power	adjust V_C for $P_L = 1 \text{ W}$; bandwidth = 30 kHz; $f_n = f_o + 45 \text{ MHz}$	–	–	–90	dBm
d_{im}	reverse intermodulation	$P_{Tx} = 0.9 \text{ W}$; $f_{int} = f_{Tx} - 45 \text{ MHz}$; $P_{int} = P_{Tx} - 30 \text{ dB}$; note 1	–	–	–8	dB
	ruggedness	$V_S = 5 \text{ V}$; adjust V_C for $P_L = 1.4 \text{ W}$; $V_{SWR} \leq 10 : 1$ through all phases	no degradation			

Note

1. With respect to P_{int} .

UHF amplifier modules

BGY120A; BGY120B

PACKAGE OUTLINE

PACKAGE
OUTLINE
NOT
RELEASED
FOR
GENERAL
PUBLICATION

UHF amplifier modules

BGY120A; BGY120B

DEFINITIONS

Data Sheet Status	
Objective specification	This data sheet contains target or goal specifications for product development.
Preliminary specification	This data sheet contains preliminary data; supplementary data may be published later.
Product specification	This data sheet contains final product specifications.
Limiting values	
Limiting values given are in accordance with the Absolute Maximum Rating System (IEC 134). Stress above one or more of the limiting values may cause permanent damage to the device. These are stress ratings only and operation of the device at these or at any other conditions above those given in the Characteristics sections of the specification is not implied. Exposure to limiting values for extended periods may affect device reliability.	
Application information	
Where application information is given, it is advisory and does not form part of the specification.	

LIFE SUPPORT APPLICATIONS

These products are not designed for use in life support appliances, devices, or systems where malfunction of these products can reasonably be expected to result in personal injury. Philips customers using or selling these products for use in such applications do so at their own risk and agree to fully indemnify Philips for any damages resulting from such improper use or sale.

UHF amplifier modules

BGY120A; BGY120B

NOTES

UHF amplifier modules

BGY120A; BGY120B

NOTES