



OC-12/3, STM-4/1 SONET/SDH CLOCK AND DATA RECOVERY IC

Features

Complete CDR solution includes the following:

- Supports OC-12/3, STM-4/1
- Low Power, 293 mW (TYP OC-12)
- Small Footprint: 4 mm x 4 mm
- DSPLL™ Eliminates External Loop Filter Components
- 3.3 V Tolerant Control Inputs
- Exceeds All SONET/SDH Jitter Specifications
- Jitter Generation 1.6 mUI_{RMS} (TYP)
- Device Power Down
- Loss-of-Lock Indicator
- Single 2.5 V Supply

Applications

- SONET/SDH/ATM Routers
- Add/Drop Multiplexers
- Digital Cross Connects
- Board Level Serial Links
- SONET/SDH Test Equipment
- Optical Transceiver Modules
- SONET/SDH Regenerators

Description

The Si5010 is a fully integrated low-power clock and data recovery (CDR) IC designed for high-speed serial communication systems. It extracts timing information and data from a serial input at OC-12/3 or STM-4/1 data rates. DSPLL™ technology eliminates sensitive noise entry points thus making the PLL less susceptible to board-level interaction and helping to ensure optimal jitter performance in the application.

The Si5010 represents an industry-leading combination of low jitter, low power, and small size for high speed CDRs. It operates from a single 2.5 V supply over the industrial temperature range (-40°C to 85°C).

Functional Block Diagram

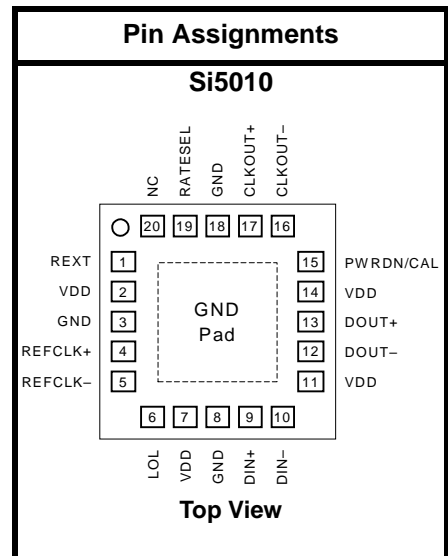
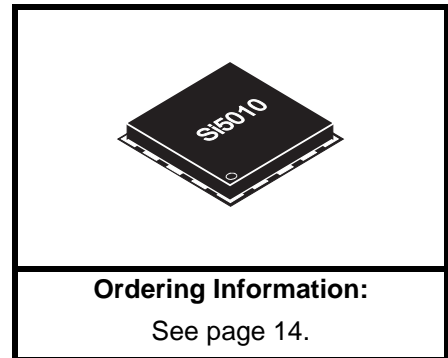
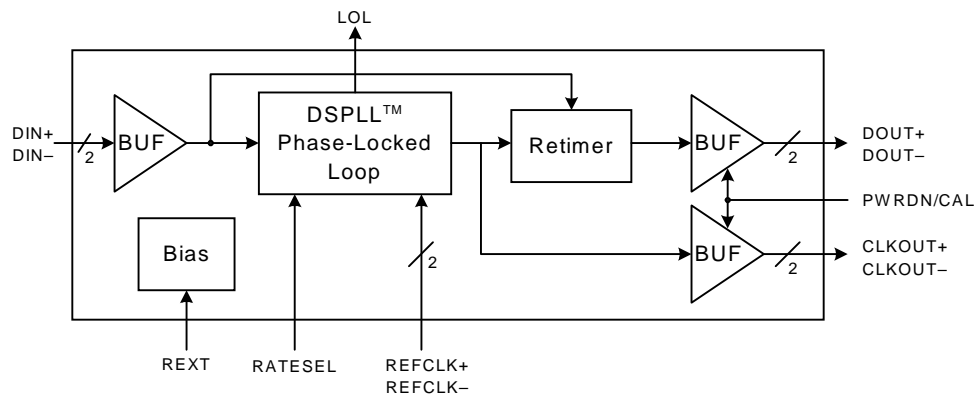

TABLE OF CONTENTS

<u>Section</u>	<u>Page</u>
Detailed Block Diagram	4
Electrical Specifications	5
Functional Description	9
DSPLL™	9
PLL Self-Calibration	9
Multi-Rate Operation	9
Reference Clock Detect	9
Lock Detect	9
Power Down	10
Device Grounding	10
Bias Generation Circuitry	10
Differential Input Circuitry	11
Differential Output Circuitry	11
Pin Descriptions: Si5010	12
Ordering Guide	14
Package Outline	15
Contact Information	16



Detailed Block Diagram

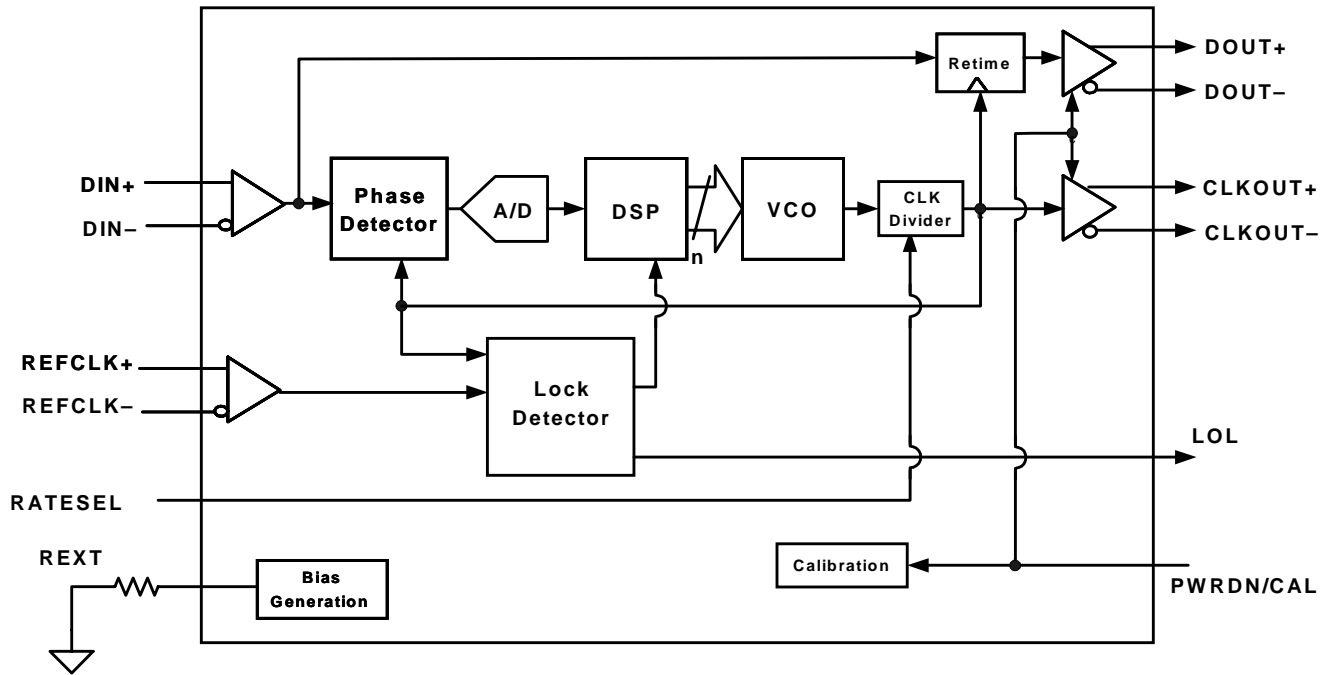

Figure 1. Detailed Block Diagram

Electrical Specifications

Table 1. Recommended Operating Conditions

Parameter	Symbol	Test Condition	Min ¹	Typ	Max ¹	Unit
Ambient Temperature	T_A		-40	25	85	°C
Si5010 Supply Voltage ²	V_{DD}		2.375	2.5	2.625	V

Notes:

1. All minimum and maximum specifications are guaranteed and apply across the recommended operating conditions. Typical values apply at nominal supply voltages and an operating temperature of 25°C unless otherwise stated.
2. The Si5010 specifications are guaranteed when using the recommended application circuit (including component tolerance) of Figure 5 on page 8.

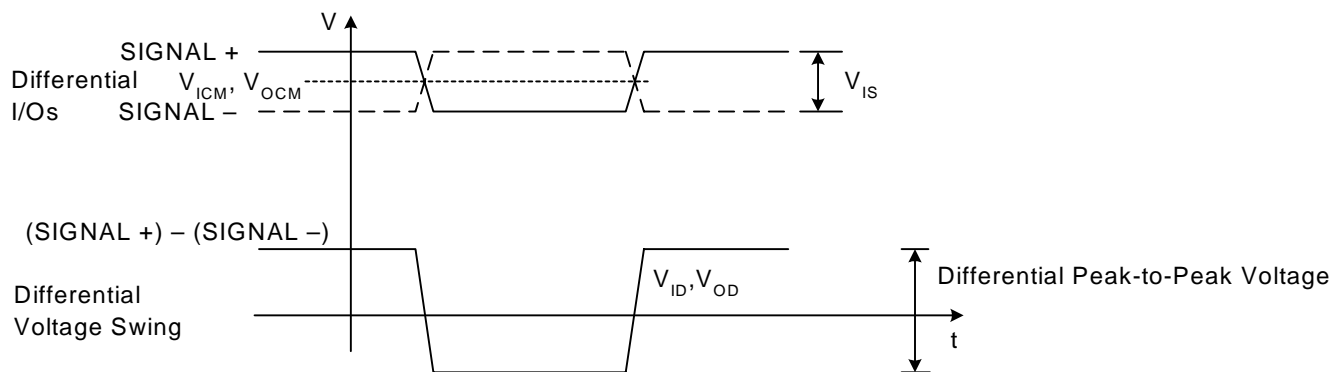

Figure 2. Differential Voltage Measurement

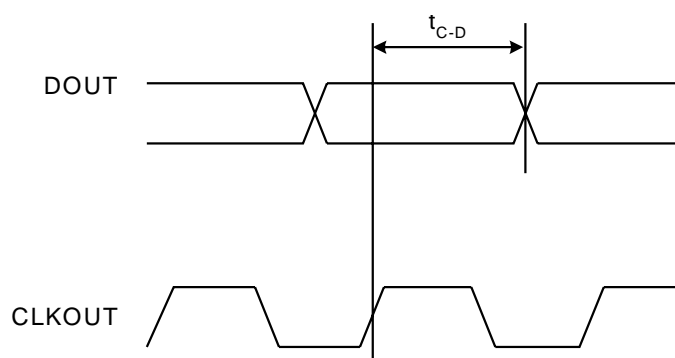

Figure 3. Clock to Data Timing

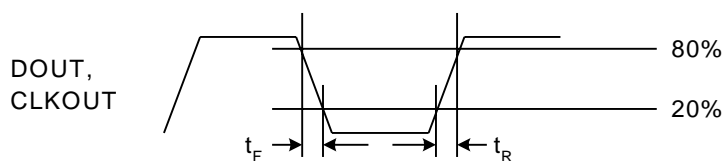

Figure 4. DOUT and CLKOUT Rise/Fall Times

Table 2. DC Characteristics
 $(V_{DD} = 2.5\text{ V} \pm 5\%, T_A = -40^\circ\text{C to } 85^\circ\text{C})$

Parameter	Symbol	Test Condition	Min	Typ	Max	Unit
Supply Current	I_{DD}					
OC-12			—	117	127	mA
OC-3			—	124	134	
Power Dissipation	P_D					
OC-12			—	293	333	mW
OC-3			—	310	352	
Common Mode Input Voltage (DIN, REFCLK)	V_{ICM}	varies with V_{DD}	—	$.80 \cdot V_{DD}$	—	V
Input Voltage Range* (DIN+, DIN-, REFCLK+, REFCLK-)	V_{IS}	See Figure 2	—	—	750	mV
Differential Input Voltage Swing* (DIN, REFCLK)	V_{ID}	See Figure 2	200	—	1500	mV (pk-pk)
Input Impedance (DIN, REFCLK)	R_{IN}	Line-to-Line	84	100	116	Ω
Differential Output Voltage Swing (DOUT)	V_{OD}	100 Ω Load Line-to-Line	TBD	940	TBD	mV (pk-pk)
Differential Output Voltage Swing (CLKOUT)	V_{OD}	100 Ω Load Line-to-Line	TBD	900	TBD	mV (pk-pk)
Output Common Mode Voltage (DOUT,CLKOUT)	V_{OCM}	100 Ω Load Line-to-Line	—	$V_{DD} - 0.7$	—	V
Output Impedance (DOUT,CLKOUT)	R_{OUT}	Single-ended	84	100	116	Ω
Output Short to GND (DOUT,CLKOUT)	$I_{SC(-)}$		—	25	TBD	mA
Output Short to V_{DD} (DOUT,CLKOUT)	$I_{SC(+)}$		TBD	-15	—	mA
Input Voltage Low (LVTTTL Inputs)	V_{IL}		—	—	.8	V
Input Voltage High (LVTTTL Inputs)	V_{IH}		2.0	—	—	V
Input Low Current (LVTTTL Inputs)	I_{IL}		—	—	10	μA
Input High Current (LVTTTL Inputs)	I_{IH}		—	—	10	μA
Output Voltage Low (LVTTTL Outputs)	V_{OL}	$I_O = 2\text{ mA}$	—	—	0.4	V
Output Voltage High (LVTTTL Outputs)	V_{OH}	$I_O = 2\text{ mA}$	2.0	—	—	V
Input Impedance (LVTTTL Inputs)	R_{IN}		10	—	—	k Ω
PWRDN/CAL Leakage Current	I_{PWRDN}	$V_{PWRDN} \geq 0.8\text{ V}$	TBD	25	TBD	μA

***Note:** The DIN and REFCLK inputs may be driven differentially or single-endedly. When driving single-endedly, the voltage swing of the signal applied to the active input must exceed the specified minimum Differential Input Voltage Swing (V_{ID} min) and the unused input must be tied to ground. When driving differentially, the difference between the positive and negative input signals must exceed V_{ID} min. (Each individual input signal needs to swing only half of this range.) In either case, the voltage applied to any individual pin (DIN+, DIN-, REFCLK+, or REFCLK-) must not exceed the specified maximum Input Voltage Range (V_{IS} max).

Table 3. AC Characteristics (Clock & Data) $(V_A = 2.5\text{ V} \pm 5\%, T_A = -40^\circ\text{C to } 85^\circ\text{C})$

Parameter	Symbol	Test Condition	Min	Typ	Max	Unit
Output Clock Rate	f_{CLK}		.15	—	666	MHz
Output Rise Time	t_R	Figure 4	—	100	TBD	ps
Output Fall Time	t_F	Figure 4	—	100	TBD	ps
Clock to Data Delay	$t_{(c-d)}$	Figure 3				
OC-12			—	890	TBD	ps
OC-3			—	4100	TBD	ps
Input Return Loss		100 kHz–622 MHz	18.7	—	—	dB

Table 4. AC Characteristics (PLL Characteristics) $(V_{\text{DD}} = 2.5\text{ V} \pm 5\%, T_A = -40^\circ\text{C to } 85^\circ\text{C})$

Parameter	Symbol	Test Condition	Min	Typ	Max	Unit
Jitter Tolerance (OC-12 Mode)*	$J_{\text{TOL(PP)}}$	$f = 30\text{ Hz}$	40	TBD	—	U_{Ipp}
		$f = 300\text{ Hz}$	4	TBD	—	U_{Ipp}
		$f = 25\text{ kHz}$	4	TBD	—	U_{Ipp}
		$f = 250\text{ kHz}$	0.4	TBD	—	U_{Ipp}
Jitter Tolerance (OC-3 Mode)*	$J_{\text{TOL(PP)}}$	$f = 30\text{ Hz}$	40	TBD	—	U_{Ipp}
		$f = 300\text{ Hz}$	4	TBD	—	U_{Ipp}
		$f = 6.5\text{ kHz}$	4	TBD	—	U_{Ipp}
		$f = 65\text{ kHz}$	0.4	TBD	—	U_{Ipp}
RMS Jitter Generation*	$J_{\text{GEN(RMS)}}$	with no jitter on serial data	—	1.6	3.0	mUI
Peak-to-Peak Jitter Generation	$J_{\text{GEN(PP)}}$	with no jitter on serial data	—	25	55	mUI
Jitter Transfer Bandwidth*	J_{BW}	OC-12 Mode	—	—	500	kHz
		OC-3 Mode	—	—	130	kHz
Jitter Transfer Peaking*	J_P	$f < 2\text{ MHz}$	—	.03	0.1	dB
Acquisition Time	T_{AQ}	After falling edge of PWRDN/CAL	1.45	1.5	1.7	ms
		From the return of valid data	40	60	150	μs
Input Reference Clock Duty Cycle	C_{DUTY}		40	50	60	%
Reference Clock Range			19.44		155.52	MHz
Input Reference Clock Frequency Tolerance	C_{TOL}		-100	—	100	ppm
Frequency Difference at which Receive PLL goes out of Lock (REFCLK compared to the divided down VCO clock)	LOL		TBD	600	TBD	ppm
Frequency Difference at which Receive PLL goes into Lock (REFCLK compared to the divided down VCO clock)	LOCK		TBD	300	TBD	ppm

*Note: Bellcore specifications: GR-253-CORE, Issue 2, December 1995. Using PRBS $2^{23}-1$ data pattern.



Si5010

Table 5. Absolute Maximum Ratings

Parameter	Symbol	Value	Unit
DC Supply Voltage	V_{DD}	-0.5 to 2.8	V
LVTTL Input Voltage	V_{DIG}	-0.3 to 3.6	V
Differential Input Voltages	V_{DIF}	-0.3 to ($V_{DD} + 0.3$)	V
Maximum Current any output PIN		± 50	mA
Operating Junction Temperature	T_{JCT}	-55 to 150	$^{\circ}C$
Storage Temperature Range	T_{STG}	-55 to 150	$^{\circ}C$
Lead Temperature (soldering 10 seconds)		300	$^{\circ}C$
ESD HBM Tolerance (100 pf, 1.5 k Ω)		1	kV

Note: Permanent device damage may occur if the above Absolute Maximum Ratings are exceeded. Functional operation should be restricted to the conditions as specified in the operational sections of this data sheet. Exposure to absolute maximum rating conditions for extended periods may affect device reliability.

Table 6. Thermal Characteristics

Parameter	Symbol	Test Condition	Value	Unit
Thermal Resistance Junction to Ambient	Φ_{JA}	Still Air	38	$^{\circ}C/W$

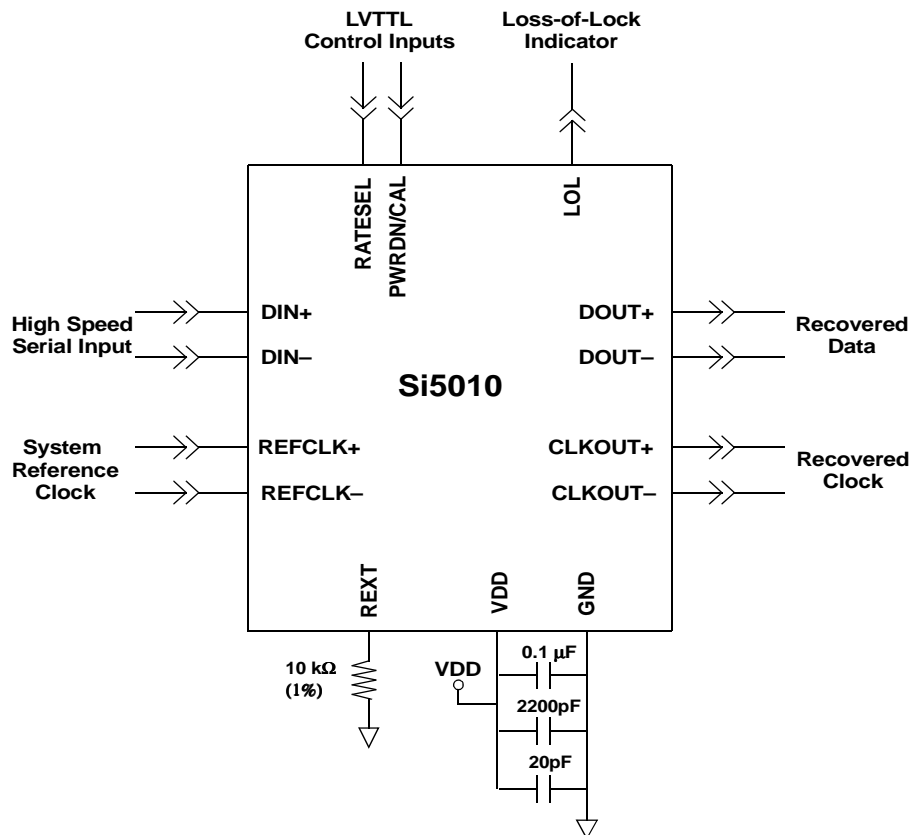

Figure 5. Si5010 Typical Application Circuit

Functional Description

The Si5010 utilizes a phase-locked loop (PLL) to recover a clock synchronous to the input data stream. This clock is used to retiming the data, and both the recovered clock and data are output synchronously via current mode logic (CML) drivers. Optimal jitter performance is obtained by using Silicon Laboratories' DSPLL™ technology to eliminate the noise entry points caused by external PLL loop filter components.

DSPLL™

The phase-locked loop structure (shown in Figure 1 on page 4) utilizes Silicon Laboratories' DSPLL technology to eliminate the need for external loop filter components found in traditional PLL implementations. This is achieved by using a digital signal processing (DSP) algorithm to replace the loop filter commonly found in analog PLL designs. This algorithm processes the phase detector error term and generates a digital control value to adjust the frequency of the voltage controlled oscillator (VCO). Because external loop filter components are not required, sensitive noise entry points are eliminated thus making the DSPLL less susceptible to board-level noise sources that make SONET/SDH jitter compliance difficult to attain.

PLL Self-Calibration

The Si5020 achieves optimal jitter performance by using self-calibration circuitry to set the loop gain parameters within the DSPLL. For the self-calibration circuitry to operate correctly, the power supply voltage must exceed 2.25 V when calibration occurs. For best performance, the user should force a self-calibration once the supply has stabilized on power-up.

A self-calibration can be initiated by forcing a high-to-low transition on the power-down control input, PWRDN/CAL, while a valid reference clock is supplied to the REFCLK input. The PWRDN/CAL input should be held high at least 1 μ S before transitioning low to guarantee a self-calibration. Several application circuits that could be used to initiate a power-on self-calibration are provided in Silicon Laboratories application note AN42.

Multi-Rate Operation

The Si5010 supports clock and data recovery for OC-12/3 and STM-4/1 data streams.

Multi-rate operation is achieved by configuring the device to divide down the output of the VCO to the desired data rate. The RATESEL configuration and associated data rates are given in Table 7.

Table 7. Data-Rate Configuration

RATESEL	SONET/SDH
0	622.08 Mbps
1	155.52 Mbps

Reference Clock Detect

The Si5020 uses the reference clock to center the VCO operating frequency so that clock and data can be recovered from the input data stream. The VCO operates at an integer multiple of the REFCLK frequency. (See "Lock Detect" section.) The device will self configure for operation with one of three reference clock frequencies. This eliminates the need to externally configure the device to operate with a particular reference clock. The REFCLK frequency should be 19.44 MHz, 77.76 MHz, or 155.52 MHz with a frequency accuracy of ± 100 ppm.

Lock Detect

The Si5010 provides lock-detect circuitry that indicates whether the DSPLL has frequency locked with the incoming data signal (DIN). The circuit compares the frequency of a divided down version of the CLKOUT output with the frequency of the supplied reference clock. If the divided CLKOUT frequency deviates from that of the reference clock by the amount specified in Table 4 on page 7, the PLL is declared out of lock, and the loss-of-lock (LOL) pin is asserted.

While out of lock, the DSPLL will try to reacquire lock with the input data. During reacquisition, the clock output (CLKOUT) will drift over a range of approximately 1% relative to the supplied reference clock. The LOL output will remain asserted until the divided clock output frequency differs from the REFCLK frequency by less than the amount specified in Table 4.

Note: LOL is not asserted during PWRDN/CAL.

PLL Performance

The PLL implementation used in the Si5010 is fully compliant with the jitter specifications proposed for SONET/SDH equipment by Bellcore GR-253-CORE, Issue 2, December 1995 and ITU-T G.958.

Jitter Tolerance

The Si5010's tolerance to input jitter exceeds that of the Bellcore/ITU mask shown in Figure 6. This mask defines the level of peak-to-peak sinusoid jitter that must be tolerated when applied to the differential data input of the device.



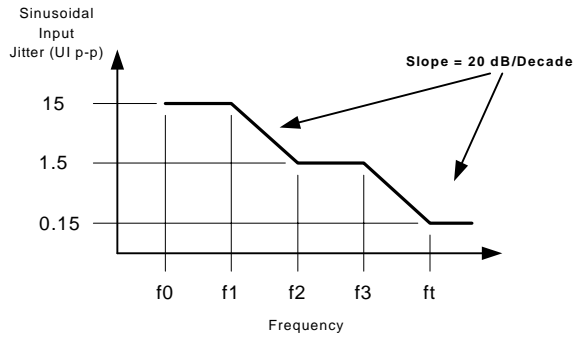

SONET Data Rate	F0 (Hz)	F1 (Hz)	F2 (Hz)	F3 (kHz)	Ft (kHz)
OC-12	10	30	300	25	250
OC-3	10	30	300	6.5	65

Figure 6. Jitter Tolerance Specification

Jitter Transfer

The Si5010 is fully compliant with the relevant Bellcore/ITU specifications related to SONET/SDH jitter transfer. Jitter transfer is defined as the ratio of output signal jitter to input signal jitter as a function of jitter frequency (see Figure 7). These measurements are made with an input test signal that is degraded with sinusoidal jitter whose magnitude is defined by the mask in Figure 6.

Jitter Generation

The Si5010 meets all relevant specifications for jitter generation proposed for SONET/SDH equipment. The jitter generation specification defines the amount of jitter that may be present on the recovered clock and data outputs when a jitter free input signal is provided. The Si5010 typically generates less than 1.6 mUI_{RMS} of jitter when presented with jitter-free input data.

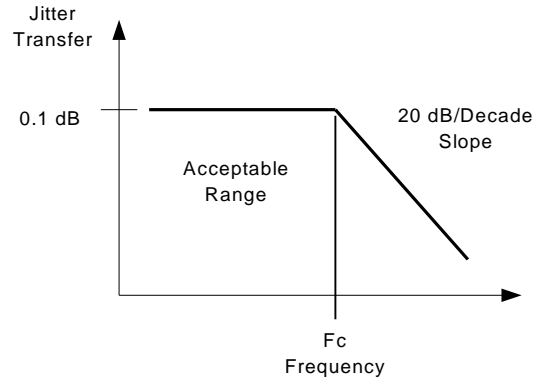

SONET Data Rate	Fc (kHz)
OC-12	500
OC-3	130

Figure 7. Jitter Transfer Specification

Power Down

The Si5010 provides a power down pin, PWRDN/CAL, that disables the device. When the PWRDN/CAL pin is driven “high”, the positive and negative terminals of CLKOUT and DOUT are each tied to VDD through 100 Ω on-chip resistors. This feature is useful in reducing power consumption in applications that employ redundant serial channels. When PWRDN/CAL is released (set to “low”) the digital logic resets to a known initial condition, recalibrates the DSPLL, and will begin to lock to the data stream.

Note: LOL is not asserted when the device is in the power down state.

Device Grounding

The Si5010 uses the GND pad on the bottom of the 20-pin micro leaded package (MLP) for device ground. This pad should be connected directly to the analog supply ground. See Figures 10 and 11 for the ground (GND) pad location.

Bias Generation Circuitry

The Si5010 makes use of an external resistor to set internal bias currents. The external resistor allows precise generation of bias currents which significantly reduces power consumption versus traditional implementations that use an internal resistor. The bias generation circuitry requires a 10 kΩ (1%) resistor connected between REXT and GND.

Differential Input Circuitry

The Si5010 provides differential inputs for both the high speed data (DIN) and the reference clock (REFCLK) inputs. An example termination for these inputs is shown in Figure 8. In applications where direct DC coupling is possible, the 0.1 μF capacitors may be omitted. The DIN and REFCLK input amplifiers require an input signal with a minimum differential peak-to-peak voltage listed in Table 2 on page 6.

Differential Output Circuitry

The Si5010 utilizes a current mode logic (CML) architecture to output both the recovered clock (CLKOUT) and data (DOUT). An example of output termination with AC coupling is shown in Figure 9. In applications in which direct DC coupling is possible, the 0.1 μF capacitors may be omitted. The differential peak-to-peak voltage swing of the CML architecture is listed in Table 2 on page 6.

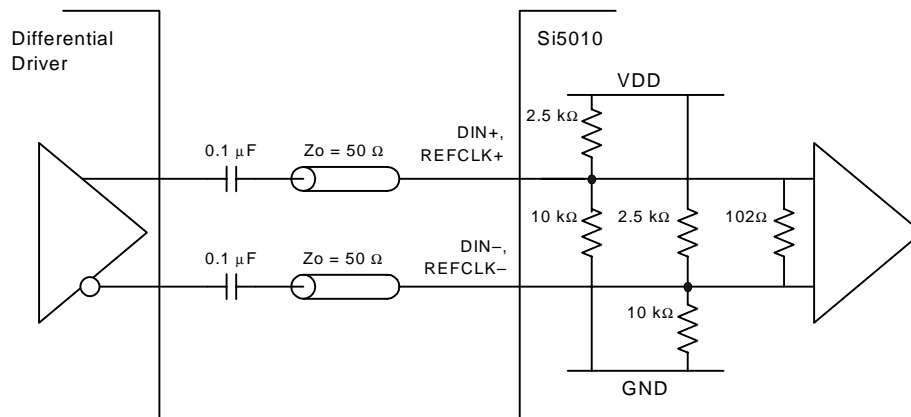

Figure 8. Input Termination for DIN and REFCLK (AC Coupled)

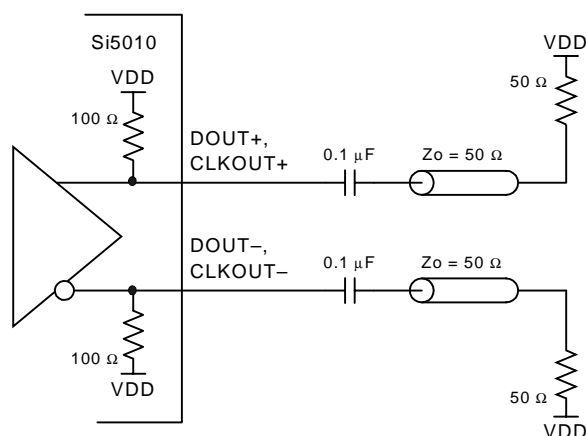

Figure 9. Output Termination for DOUT and CLKOUT (AC Coupled)

Si5010

Pin Descriptions: Si5010

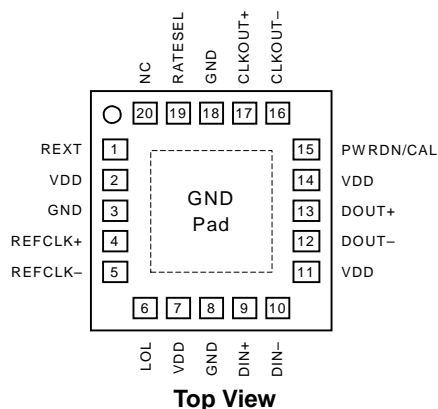

Figure 10. Si5010 Pin Configuration

Table 8. Si5010 Pin Descriptions

Pin #	Pin Name	I/O	Signal Level	Description
1	REXT			External Bias Resistor. This resistor is used by onboard circuitry to establish bias currents within the device. This pin must be connected to GND through a 10 k Ω (1%) resistor.
2, 7, 11, 14	VDD		2.5 V	Supply Voltage. Nominally 2.5 V.
3, 8, 18, and GND Pad	GND		GND	Supply Ground. Nominally 0.0 V. The GND pad found on the bottom of the 20-pin micro leaded package (see Figure 11) must be connected directly to supply ground.
4, 5	REFCLK+, REFCLK-	I	See Table 2	Differential Reference Clock. The reference clock sets the initial operating frequency used by the onboard PLL for clock and data recovery. Additionally, the reference clock is used to derive the clock output when no data is present.
6	LOL	O	LVTTTL	Loss of Lock. This output is driven high when the recovered clock frequency deviates from the reference clock by the amount specified in Table 4 on page 7.
9, 10	DIN+, DIN-	I	See Table 2	Differential Data Input. Clock and data are recovered from the differential signal present on these pins.

Table 8. Si5010 Pin Descriptions (Continued)

Pin #	Pin Name	I/O	Signal Level	Description
12, 13	DOUT–, DOUT+	O	CML	Differential Data Output. The data output signal is a retimed version of the data recovered from the signal present on DIN. It is phase aligned with CLKOUT and is updated on the rising edge of CLKOUT.
15	PWRDN/CAL	I	LVTTTL	Power Down. To shut down the high-speed outputs and reduce power consumption, hold this pin high. For normal operation, hold this pin low. Calibration. To initiate an internal self-calibration, force a high-to-low transition on this pin. (See "PLL Self-Calibration" on page 9.) Note: This input has a weak internal pulldown.
16, 17	CLKOUT–, CLKOUT+	O	CML	Differential Clock Output. The output clock is recovered from the data signal present on DIN. In the absence of data, the output clock is derived from REFCLK.
19	RATESEL	I	LVTTTL	Data Rate Select. This pin configures the onboard PLL for clock and data recovery at one of two user selectable data rates. See Table 7 for configuration settings. Note: This input has a weak internal pulldown.
20	NC			No Connect. This pin should be tied to ground.



Si5010

Ordering Guide

Table 9. Ordering Guide

Part Number	Package	Temperature
Si5010-BM	20-pin MLP	-40°C to 85°C

Package Outline

Figure 11 illustrates the package details for the Si5010. Table 10 lists the values for the dimensions shown in the illustration.

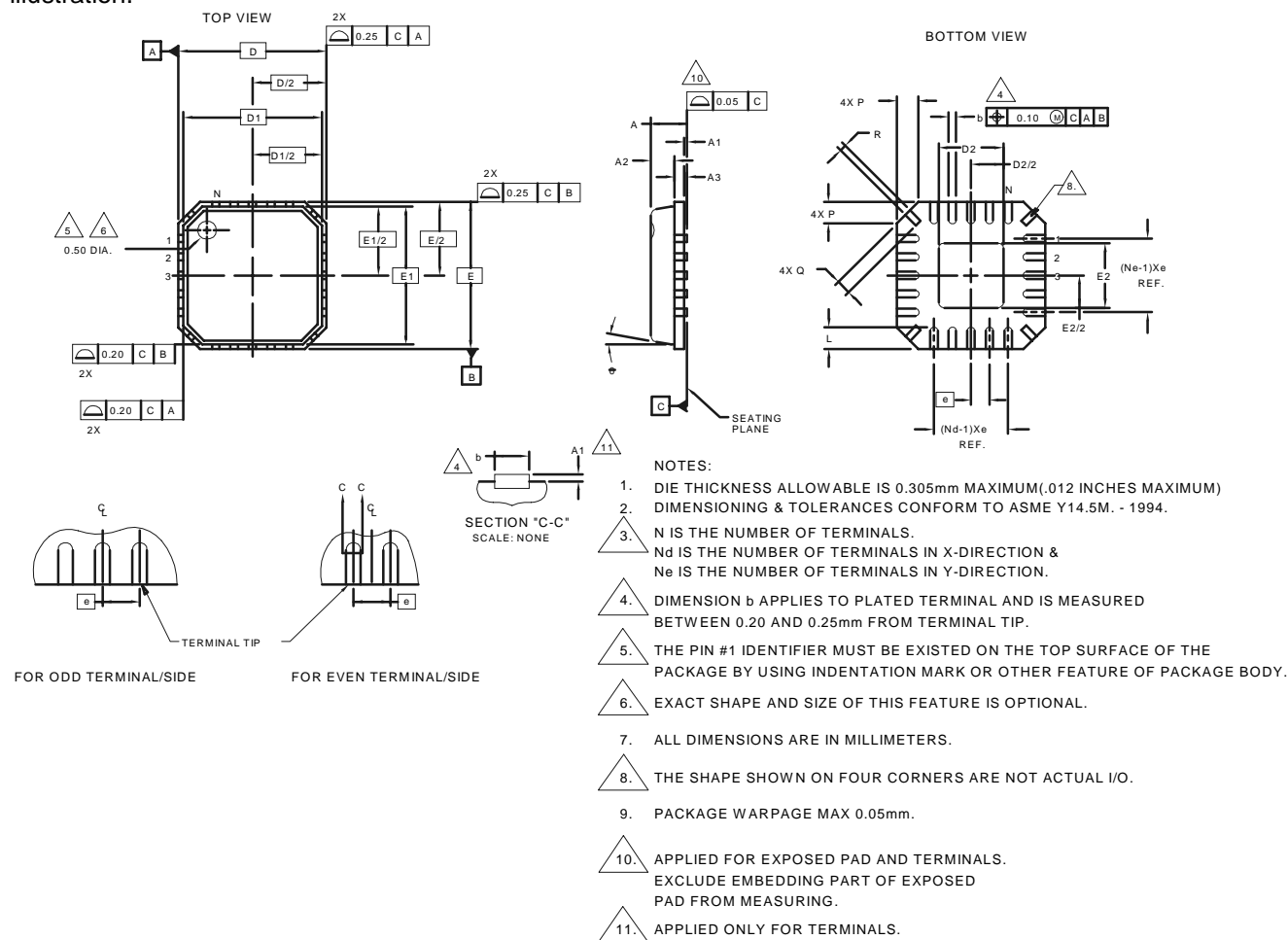

Figure 11. 20-pin Micro Leaded Package (MLP)

Table 10. Package Diagram Dimensions

Symbol	Millimeters		
	Min	Nom	Max
A	—	0.85	1.00
A1	0.00	0.01	0.05
A2	—	0.65	0.80
A3	0.20 REF		
b	0.23	0.28	0.35
D	4.00 BSC		
D1	3.75 BSC		
D2	1.95	2.10	2.25
e	0.50 BSC		
E	4.00 BSC		

Symbol	Millimeters		
	Min	Nom	Max
E1	3.75 BSC		
E2	1.95	2.10	2.25
N	20		
Nd	5		
Ne	5		
L	0.50	0.60	0.75
P	0.24	0.42	0.60
Q	0.30	0.40	0.65
R	0.13	0.17	0.23
θ	—	—	12°

Contact Information

Silicon Laboratories Inc.

4635 Boston Lane
Austin, TX 78735
Tel: 1+(512) 416-8500
Fax: 1+(512) 416-9669
Toll Free: 1+(877) 444-3032
Email: productinfo@silabs.com
Internet: www.silabs.com

The information in this document is believed to be accurate in all respects at the time of publication but is subject to change without notice. Silicon Laboratories assumes no responsibility for errors and omissions, and disclaims responsibility for any consequences resulting from the use of information included herein. Additionally, Silicon Laboratories assumes no responsibility for the functioning of undescribed features or parameters. Silicon Laboratories reserves the right to make changes without further notice. Silicon Laboratories makes no warranty, representation or guarantee regarding the suitability of its products for any particular purpose, nor does Silicon Laboratories assume any liability arising out of the application or use of any product or circuit, and specifically disclaims any and all liability, including without limitation consequential or incidental damages. Silicon Laboratories products are not designed, intended, or authorized for use in applications intended to support or sustain life, or for any other application in which the failure of the Silicon Laboratories product could create a situation where personal injury or death may occur. Should Buyer purchase or use Silicon Laboratories products for any such unintended or unauthorized application, Buyer shall indemnify and hold Silicon Laboratories harmless against all claims and damages.

Silicon Laboratories, Silicon Labs, and DSPLL are trademarks of Silicon Laboratories Inc.

Other products or brandnames mentioned herein are trademarks or registered trademarks of their respective holders.