

CD-ROM spindle motor driver

BA6855AFM

The BA6855AFM is a CD-ROM motor driver with a built-in motor power supply switching regulator. The switching regulator allows low-power designs, and reduced thermal dissipation from the IC. It is possible to select reverse brake and short brake modes.

●Applications

CD-ROM, CD-R, CD-RW, DVD-ROM, and DVD-RAM

●Features

- 1) Motor switching regulator on chip.
- 2) Selectable brake mode via BR pin.
- 3) FG signal output also possible at power save via FGS.

●Absolute maximum ratings (Ta = 25°C)

Parameter	Symbol	Limits	Unit
Applied voltage (power supply)	V _{CC}	7	V
Applied voltage (switching power supply)	V _R	15	V
Power dissipation	P _d	2200*1	mW
Operating temperature	T _{opr}	-20~+75	°C
Storage temperature	T _{stg}	-55~+150*2	°C
Junction temperature	T _{jmax}	150	°C
Output current	I _{OMAX}	1300*3	mA

*1 Reduced by 17.6mW for each increase in Ta of 1°C over 25°C (when mounted on a 70mm×70mm×1.6mm glass epoxy PCB).

*2 Do not exceed T_j=150°C.

*3 Should not exceed Pd or ASO values.

●Recommended operating conditions (Ta = 25°C)

Parameter	Symbol	Limits	Unit
Power supply voltage	V _{CC}	4.5~5.5	V
	V _M	3~14	V

● Block diagram

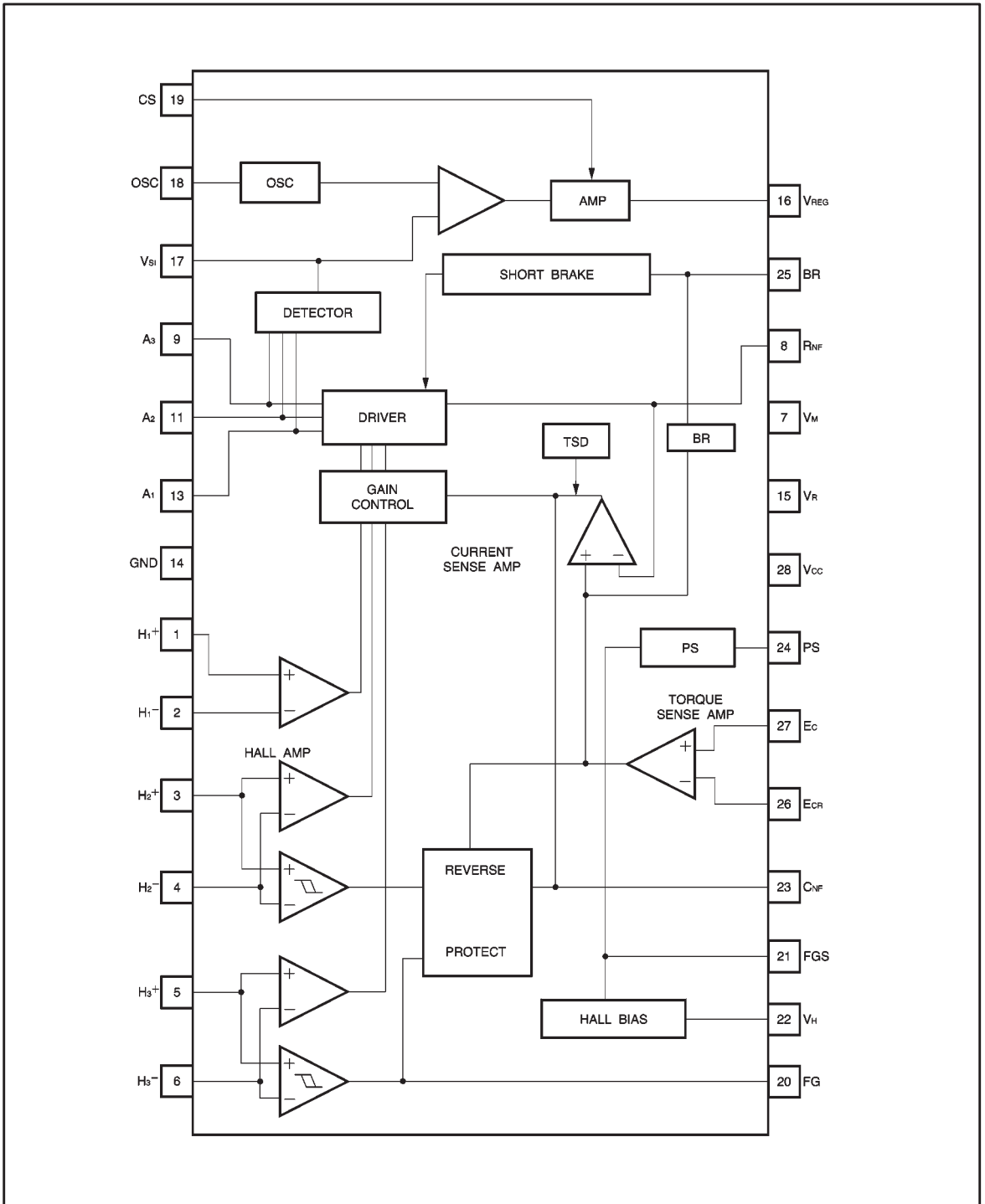

● Pin descriptions

Pin No.	Pin name	Function
1	H ₁ ⁺	Hall signal input
2	H ₁ ⁻	Hall signal input
3	H ₂ ⁺	Hall signal input
4	H ₂ ⁻	Hall signal input
5	H ₃ ⁺	Hall signal input
6	H ₃ ⁻	Hall signal input
7	V _M	Motor power supply
8	R _{NF}	For connection of resistor for output current detection
9	A ₃	Output
10	N.C.	—
11	A ₂	Output
12	N.C.	—
13	A ₁	Output
14	GND	GND
15	V _R	Switching power supply
16	V _{REG}	Switching regulator output (SINK output)
17	V _{SI}	Lower-side saturation detector output
18	OSC	Oscillator capacitor output
19	CS	Lower-side saturation voltage setting
20	FG	FG signal output
21	FGS	FG switch for PS
22	V _H	Hall bias
23	C _{NF}	For connection of phase compensation capacitor
24	PS	Power save
25	BR	Brake mode switch
26	E _{CR}	Torque control reference
27	E _C	Torque control
28	V _{CC}	Power supply
FIN	FIN	GND

* FIN must be connected to GND.

●Electrical characteristics (unless otherwise noted, $T_a = 25^\circ\text{C}$, $V_{CC} = 5\text{V}$, $V_R = 12\text{V}$, and $V_M = 12\text{V}$)

Parameter	Symbol	Min.	Typ.	Max.	Unit	Conditions
〈Total〉						
Circuit current 1	I_{CC1}	—	9	14	mA	Power save off
Circuit current 2	I_{CC2}	—	2.5	5	mA	Only FG and V_H operating
Circuit current 3	I_{CC3}	—	0	0.2	mA	Power save on (FGS=L)
〈Power save〉						
ON voltage range	V_{PSON}	—	—	1.0	V	—
OFF voltage range	V_{PSOFF}	2.5	—	—	V	—
〈Hall bias〉						
Hall bias voltage	V_{HB}	0.5	0.9	1.5	V	$I_{HB}=10\text{mA}$
〈Hall amplifier〉						
Input bias current	I_{HA}	—	0.7	3.0	μA	—
Same phase input voltage range	V_{HAR}	1.5	—	4.0	V	—
Minimum input level	V_{INH}	50	—	—	mV _{P-P}	—
Hysteresis	V_{HYS}	5	20	40	mV	—
〈Torque command〉						
E_C input voltage range	E_C	1.0	—	4.0	V	—
E_{CR} input voltage range	E_{CR}	1.6	—	3.4	V	—
Offset voltage "—"	E_{COFF-}	-80	-50	-20	mV	$E_{CR}=2.5\text{V}$
Offset voltage "+"	E_{COFF+}	20	50	80	mV	$E_{CR}=2.5\text{V}$
Input bias current	E_{CIN}	-3	—	3	μA	$E_C=E_{CR}$
Input / output gain	G_{EC}	0.8	1.0	1.2	A / V	—
〈FG〉						
FG output low level voltage	V_{FGL}	—	0.25	0.4	V	$I_{FG}=3\text{mA}$
Duty (reference value)	D_U	—	50	—	%	—
〈FGS〉						
FGS ON voltage range	V_{FGSON}	2.5	—	—	V	FG / V_H ON when PS ON
FGS OFF voltage range	V_{FGSOFF}	—	—	1.0	V	FG / V_H OFF when PS ON
OSC oscillator frequency 1	OSC1	80	125	180	kHz	$E_C=E_{CR}$ OSC=470pF
OSC oscillator frequency 2	OSC2	400	—	—	kHz	$E_C=E_{CR}$ OSC=5pF
〈Output〉						
Output saturation high level voltage	V_{OH}	—	1.0	1.4	V	—
Output saturation low level voltage	V_{OL}	—	0.4	0.7	V	—
V_M pre-drive current	I_{VMP}	—	35	70	mA	—
Output limit current	I_{TL}	560	700	840	mA	$E_{CR}=1.65\text{V}$, $E_C=0.5\text{V}$
〈BR〉						
Short brake range	V_{BRS}	2.5	—	—	V	$E_C>E_{CR}$
Reverse brake range	V_{BRR}	—	—	1.0	V	$E_C>E_{CR}$

Parameter	Symbol	Min.	Typ.	Max.	Unit	Conditions
〈Regulator〉						
Saturation detect output gain	G_{VSI}	5	10	15	V/V	—
Regulator current capacity	I_{REGO}	30	—	—	mA	—

©Not designed for radiation resistance.

● Operation notes

(1) FGS

When a high-level voltage is input to FGS, the FG output is output even when power save is on (PS = low level). Also, the Hall bias terminal stays in the operating state.

		FGS	
		H	L
PS	H	$V_H=ON$	$V_H=ON$
		$FG=ON$	$FG=ON$
	L	$V_H=ON$	$V_H=OFF$
		$FG=ON$	$FG=OFF$

(2) Switching regulator

The BA6855AFM has a switching regulator pin. The IC has an oscillator circuit, and the output is compared to the low-level voltage detector output and output on V_{REG} .

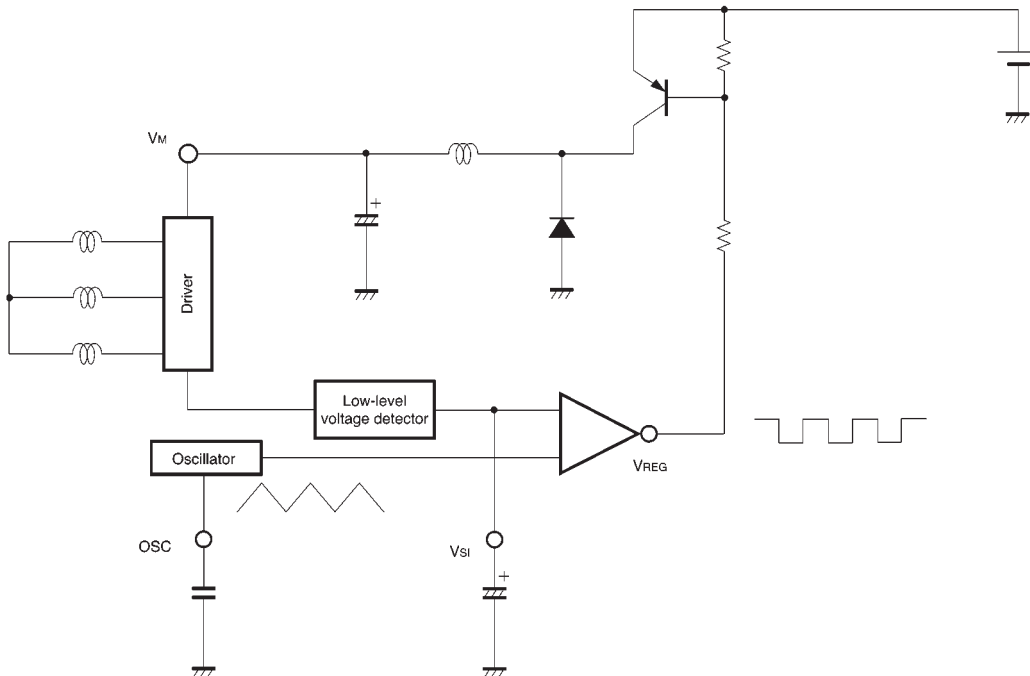
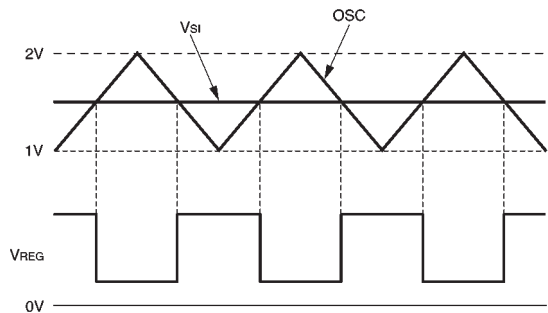

Operating in this way reduces the Collector to Emitter voltage applied on the drive stage transistor, and serves to reduce the power consumption.

Of the power consumed by the IC itself, most is consumed at the collector and emitter of the output stage transistor. This power consumption (P_c) increases as the collector to emitter voltage, and output current increases. This collector to emitter voltage is the power supply voltage less the voltage applied to the motor, and as the voltage applied to the motor decreases with the current, this amount is unnecessarily applied to the between the collector and emitter. Therefore, to effectively use power, (and to prevent power dissipation from exceeding the IC's limits) it is necessary to vary the power supply voltage in accordance with the output current. In other words, when the output current is low, the power supply voltage should be lowered, and when it is high, the power supply voltage should be increased to prevent more voltage than necessary from being applied between the collector and emitter of the output transistor.

(3) V_M variation

The result of the comparison of the output lower-side residual voltage and the triangular wave is output, and V_M is controlled by controlling an externally-connected PNP transistor to maintain the lower-side residual voltage at a roughly fixed level.

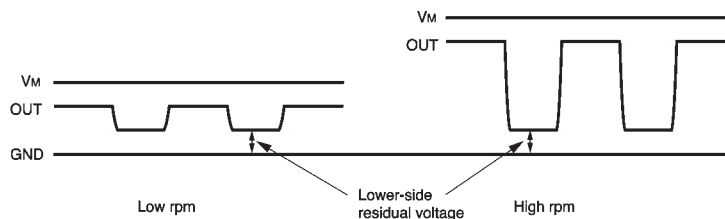

(4) The CS pin

The CS pin (pin 19) controls the lower-side residual voltage (above) in the increasing direction. Pull it down with a resistor when the IC heat generation is low, and the external transistor heat generation is high. Normally this is open.

(5) The relationship between BR and E_c / E_{CR}

When a high level is applied to the BR pin, the normal $E_c > E_{CR}$ relationship reverses ($E_c < E_{CR}$) and the IC enters short brake mode.

	$E_c < E_{CR}$	$E_c > E_{CR}$
BR=L	Normal rotation	Reverse brake
BR=H	Normal rotation	Short brake

●Application example

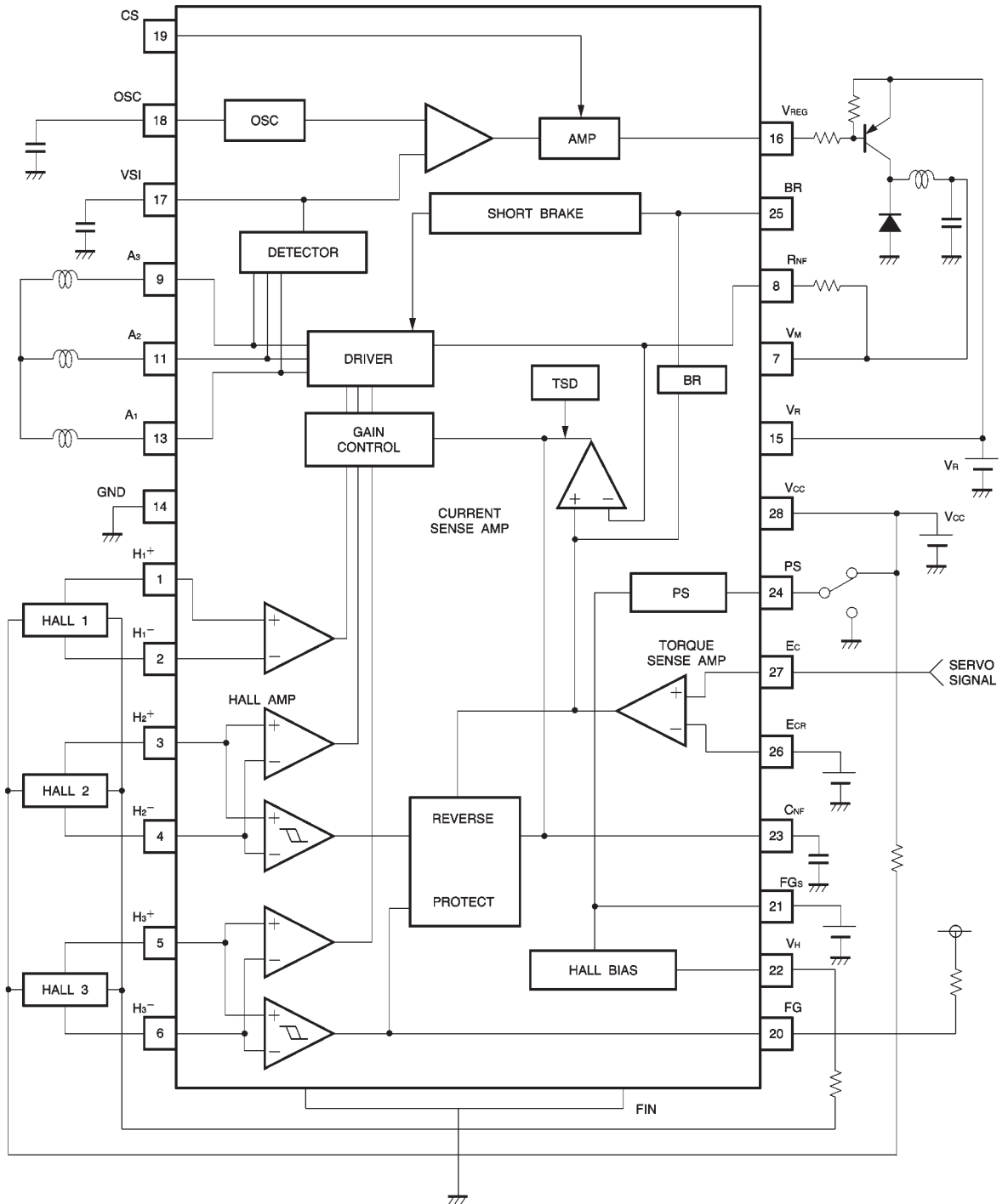

Fig.1

● Electrical characteristic curves

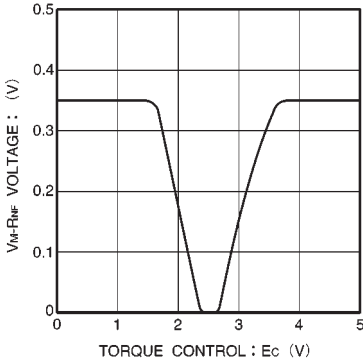

Fig.2 Torque command characteristics

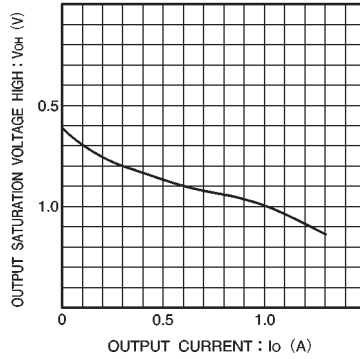

Fig.3 Upper-side output saturation voltage

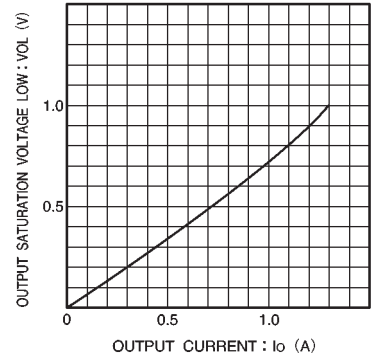

Fig.4 Lower-side output saturation voltage

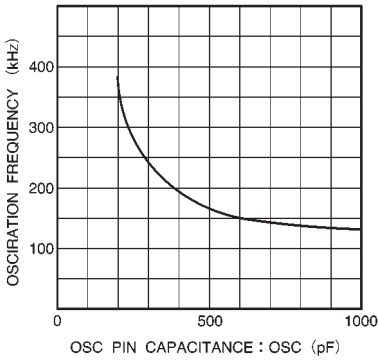

Fig.5 OSC pin frequency vs. external capacitance

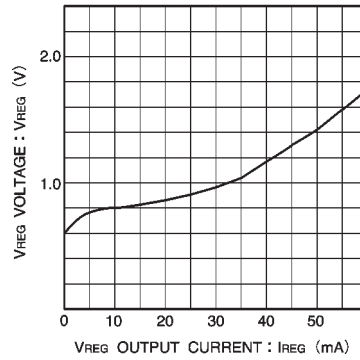

Fig.6 V_{REG} current capacity

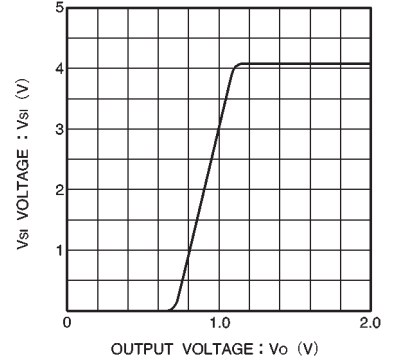

Fig.7 Output vs. V_{SI} voltage

● External dimensions (Units: mm)

