

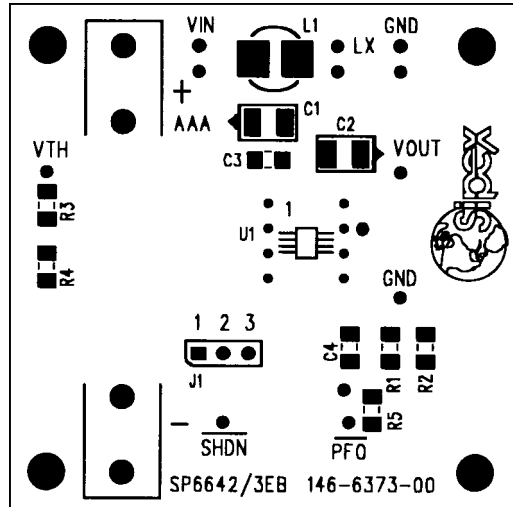

SP6642/3 Evaluation Board Manual

- Easy Evaluation for the SP6642/3 Single Cell to 2V to 5V Converter
- Only 0.37 sq. in. of Board Space needed for DC-DC Converter Circuit
- High Efficiency: 83%
- 0.75V Start-Up Voltage
- Extremely Small μ SOIC Package
- Pin-to-pin Compatible with MAX1642/3
- Connects easily to AAA Battery or Standard Power Supply Terminals



DESCRIPTION

The **SP6642/3 Evaluation Board** is designed to help the user evaluate the performance of the SP6642/3 for use as a single cell battery input to 2V to 5V output DC-DC Converter. The SP6642/3 starts up from $V_{IN} > 0.75V$ and when started accepts input voltages much less than +0.75V to as high as +1.65V and produces a regulated +3.3V output at up to 20mA. With very low quiescent current of $1.5\mu A$ at $V_{BATTERY}$, and up to 85% power efficiency, the SP6642/3 provides maximum battery life for portable applications.

The evaluation board is a completely assembled and tested surface mount board which provides easy probe access points to all SP6642/3 Inputs and Outputs so that the user can quickly connect and measure electrical characteristics and waveforms.

SP6642/3 EVALUATION BOARD

The next two sections describe the SP6642/3 Board Layout and Using the SP6642/3 Evaluation Boards. A table of SP6642/3 Pin Assignments is also included with details on Input/Output pin function. A SP6642/3 Evaluation Board List of Materials table is provided with some manufacturers part numbers to use as a reference. Finally, a schematic is included of the **SP6642/3 Evaluation Board**.

BOARD LAYOUT

The **SP6642/3 Evaluation Board** has been designed to easily and conveniently provide access to all Inputs and Outputs of the SP6642/3 device under test. Position the board with the silkscreen lettering upright (also see the drawing on the front page of this manual) and you will see the SP6642 μ SOIC labeled U1 in the center of the board, and above it the Capacitors C1,2,3 and Inductor L1 forming the DC-DC Converter circuit.

The SP6642/3 Evaluation Board provides convenient battery clips to connect the input to an AAA Battery. Or, use the V_{IN} and GND posts to directly connect to standard Power Supply binding post outputs. The Input and Output connections are made with raised female pin receptacles which can accommodate easy-hook connection leads for power and meter connections, as well as scope probe hooks and grounds for waveform measurements.

USING THE EVALUATION BOARD

The **SP6642/3 Evaluation Board** can be powered from a battery or a power supply. Connect an AAA battery using the battery clips labeled “+ “ and “-”. Or, directly connect the SP6642/3EB board to a standard pair of power supply binding posts (0.75" spacing) using the “ V_{IN} ” and “GND” posts (upper portion of the board with connections on the bottom). It is good practice to not switch power on until power connections are made to the evaluation board.

Powering Up the SP6642/3 Circuit

V_{IN} – U1-1 – Connect V_{IN} post on bottom of board directly to external Power Supply binding post positive. $V_{IN} = +0.85$ to $+1.65V$. Or, connect AAA Battery to clip labeled “+”.

GND – U1-6 – Connect GND post on bottom of board directly to external Power Supply binding post negative. Or, connect AAA Battery to clip labeled “-”.

V_{OUT} – U1-8 – Connect to Load, Meter or Scope. $V_{OUT} = +3.3V$. (Or, 2V to 5V if feedback is used with R1 & R2 on FB pin. See Datasheet.)

GND – U1-6 – Second GND Connection to Load, Meter or Scope GND.

Using the Shutdown Jumper J1 (SHDN only works with the SP6642)

The jumper J1 has 2 positions, as described below. Shutdown is a feature on the SP6642, not the SP6643. Connecting a logic low to SHDN shuts off the internal switching MOSFET and the synchronous rectifier opens to prevent current from flowing back into the part. But, the output can still drift to one diode drop below $V_{BATTERY}$, since there is still a forward path from input to output through the synchronous rectifier body diode.

J1 — To **start** the SP6642, connect Shunt on J1 to the 1-2 position. The correct output voltage ($+3.3V$) should appear on V_{OUT} . To **shutdown** the SP6642, connect J1 to the 2-3 position.

Using the Power Fail Comparator, PFI

VTH — The SP6642EB is setup to trip the PFI comparator when the input voltage is at the PFI trip voltage ($0.614V \pm 3\%$). The threshold voltage VTH ($=V_{IN}$) connects to a voltage divider R3 & R4, which sets a threshold voltage for PFI comparator input pin 6 of U1. The user may set a different trip voltage by selecting a resistor for R4 (now open) using the equation:

$$R4 = R3 * VPFI / (VTH - VPFI) \text{ where } VPFI = 0.614V$$

Note: To detect loss of power at the output, the VTH threshold pin connection to V_{IN} can be severed leaving a connection to R3, which can be used to connect to the output pin V_{IN} .

$\overline{\text{PFO}}$ – U1-3 – SP6642 or U1-4 – SP6643 Open Drain Power Fail Output. Sinks current when PFI falls below 0.614V. The SP6642EB has this pin pulled up to V_{OUT} through 100k Ω resistor R5, which will draw 30 μ A when power fail is asserted low.

Evaluating Output Voltages Other than 3.3V

FB – U1-5 – Connects to R1, R2 output feedback divider. The SP6642/3EB is set for 3.3V output since R1 is open on the board, and R2 shorts FB to GND. To set an output voltage in the range 2V to 5V, first cut the short on the board across R2, then connect surface mount resistors R1 & R2 according to the voltage divider equation:

$$R1 = R2 (V_{\text{OUT}}/V_{\text{REF}} - 1)$$

where R2 should be 100K to 1M since FB leakage = 10nA max and $V_{\text{REF}} = 1.25\text{V}$

Evaluating the SP6643 Circuit

The SP6642EB comes with a SP6642EU installed. To evaluate a SP6643, you need to order samples of the SP6643EU and install one on the board. Instead of having the $\overline{\text{SHDN}}$ function, the SP6643 has a $\overline{\text{BATTLO}}$ function, which gives a low battery detection when the battery voltage drops below 1V. Be sure to remove the Shunt in J1 when using the SP6643. There are two pins on the SP6643 that differ from the SP6642, so note their use and label names differ as shown below:

$\overline{\text{BATTLO}}$ – U1-3 Use the post labeled $\overline{\text{PFO}}$. The $\overline{\text{BATTLO}}$ on the SP6643 is an Open Drain Battery-Low Output which is pulled up to V_{OUT} by 100k Ω resistor R5. When the voltage at the BATT pin is less than 1V, $\overline{\text{BATTLO}}$ goes to close to 0V indicating Low Battery.

$\overline{\text{PFO}}$ – U1-4 Use the post labeled $\overline{\text{SHDN}}$. Remove the Shunt from J1. The $\overline{\text{PFO}}$ function on the SP6643 behaves the same as the SP6642 as described previously in the section “Using the Power Fail Comparator PFI”.

SP6642/3 Evaluation Board Pin Assignments

Pin #	Pin Name	Pin Function	Input/Output Pin Name
SP6642			
1	BATT	IC Battery-Power Input	$V_{IN} +$
2	PFI	Power-Fail Input	VTH
3	$\overline{\text{PFO}}$	Open-Drain Power-Fail Output	$\overline{\text{PFO}}$
4	$\overline{\text{SHDN}}$	Active-Low Shutdown Input	$\overline{\text{SHDN}}$
5	FB	Feedback Input	
6	GND	Ground	GND
7	LX	Inductor Switching Node	LX
8	OUT	Power Output	V_{OUT}
SP6643			
1	BATT	IC Battery-Power Input	$V_{IN} +$
2	PFI	Power-Fail Input	VTH
3	$\overline{\text{BATTLO}}$	Open-Drain Battery Low Output	$\overline{\text{PFO}}$
4	$\overline{\text{PFO}}$	Open Drain Power-Fail Output	$\overline{\text{SHDN}}$
5	FB	Feedback Input	
6	GND	Ground	GND
7	LX	Inductor Switching Node	LX
8	OUT	Power Output	V_{OUT}

SP6642/3 Evaluation Board List of Materials

Ref. Des.	Qty.	Manufacturer	Part Number	Layout Size	Component	Vendor
	1	Sipex Corp.	146-6373-00	2" X 2"	SP6642/3 Eval PC Board	Sipex 978-667-7800
U1	1	Sipex Corp.	SP6642CU	uSO-8	8 pin μ SOIC Step-Up DC/DC Conv.	Sipex
C1, 2	2	Sprague Corp.	595D226X96R3B2	"B" size	Tantalum 6.3V 22 μ F SM Low ESR	Sprague 207-490-7259
C3	1	Panasonic	ECJ-VB1E104K	1206	X7R Ceramic 0.1 μ F 25V SM	Digi-Key 800-344-4539
C4	0			1206	Open	
L1	1	Sumida	CD54-101KC	5X5mm	100 μ H, 520mA Power Inductor, SM	Sumida 847-956-0666
R1,2,4	0			1206	Open	
R3,5	2	Panasonic	ERJ-8GEYJ104	1206	100K Thick FilmChip 1/8W 5% 1206	Digi-Key
+, -	1	Keystone	82	.27X.37	Snap-In Battery Clips for AAA	Digi-Key
J1	1	Sullins	PZC36SFAN	.32X.12	3-Pin Header	Digi-Key
	1	Sullins	STC02SYAN	.2X.1	Post Shunt	Digi-Key

SP6642/3 Evaluation Board Schematic

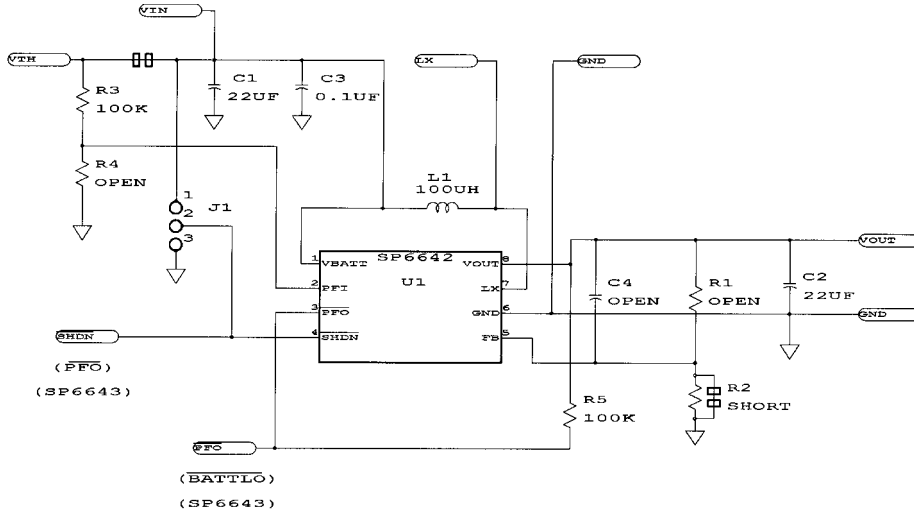

- NOTE: 1. Probe Access Points as shown: VIN are for external connections by the user.
2. Input VIH can be disconnected from VIN at ⏏ to trip PFI at other voltages.

ORDERING INFORMATION

Model
SP6642UEB

Package
SP6642 Evaluation Board



SIGNAL PROCESSING EXCELLENCE

Sipex Corporation

**Headquarters and
Sales Office**

22 Linnell Circle
Billerica, MA 01821
TEL: (978) 667-8700
FAX: (978) 670-9001
e-mail: sales@sipex.com

Sales Office

233 South Hillview Drive
Milpitas, CA 95035
TEL: (408) 934-7500
FAX: (408) 935-7600

Sipex Corporation reserves the right to make changes to any products described herein. Sipex does not assume any liability arising out of the application or use of any product or circuit described hereing; neither does it convey any license under its patent rights nor the rights of others.