

8-BIT SINGLE-CHIP MICROCONTROLLER

The μ PD78F9116 is μ PD789114 sub-series products of the 78K/0S series.

Flash memory can be written or erased electrically without having to remove it from board. Therefore, the μ PD78F9116 is best suited for prototypes in system development, low-volume production, or systems likely to be upgraded frequently.

The functions of these microcontrollers are described in the following user's manual. Refer to this manual when designing a system based on any of these microcontrollers.

μ PD789134 Sub-Series User's Manual : To be created
78K/0S Series User's Manual, Instruction : U11047E

FEATURES

- Pin-compatible with masked ROM products (other than the V_{PP} pin)
- Flash memory: 16 Kbytes
- Internal high-speed RAM: 256 bytes
- Built-in two 8-bit multipliers: 16 bits
- Variable minimum instruction execution time: From high-speed (0.4 μ s) to low-speed (1.6 μ s) (operation with the main system clock running at 5.0 MHz)
- 20 I/O ports
- Serial interface channel: Switchable between three-wire serial I/O and UART modes
- Four-channel A/D converters with an 10-bit resolution
- Three timers:
 - 16-bit timer 20
 - 8-bit timer/event counter 80
 - Watchdog timer
- Power supply voltage V_{DD} : 1.8 to 5.5 V

APPLICATIONS

Cleaners, washing machines, refrigerators, and battery chargers

ORDERING INFORMATION

Part number	Package
μ PD78F9116CT	28-pin plastic shrink DIP (400 mil)
μ PD78F9116GS	30-pin plastic shrink SOP (300 mil)

The information contained in this document is being issued in advance of the production cycle for the device. The parameters for the device may change before final production or NEC Corporation, at its own discretion, may withdraw the device prior to its production.

78K/0S SERIES DEVELOPMENT

The 78K/0S series products are shown below. The sub-series names are indicated in frames.

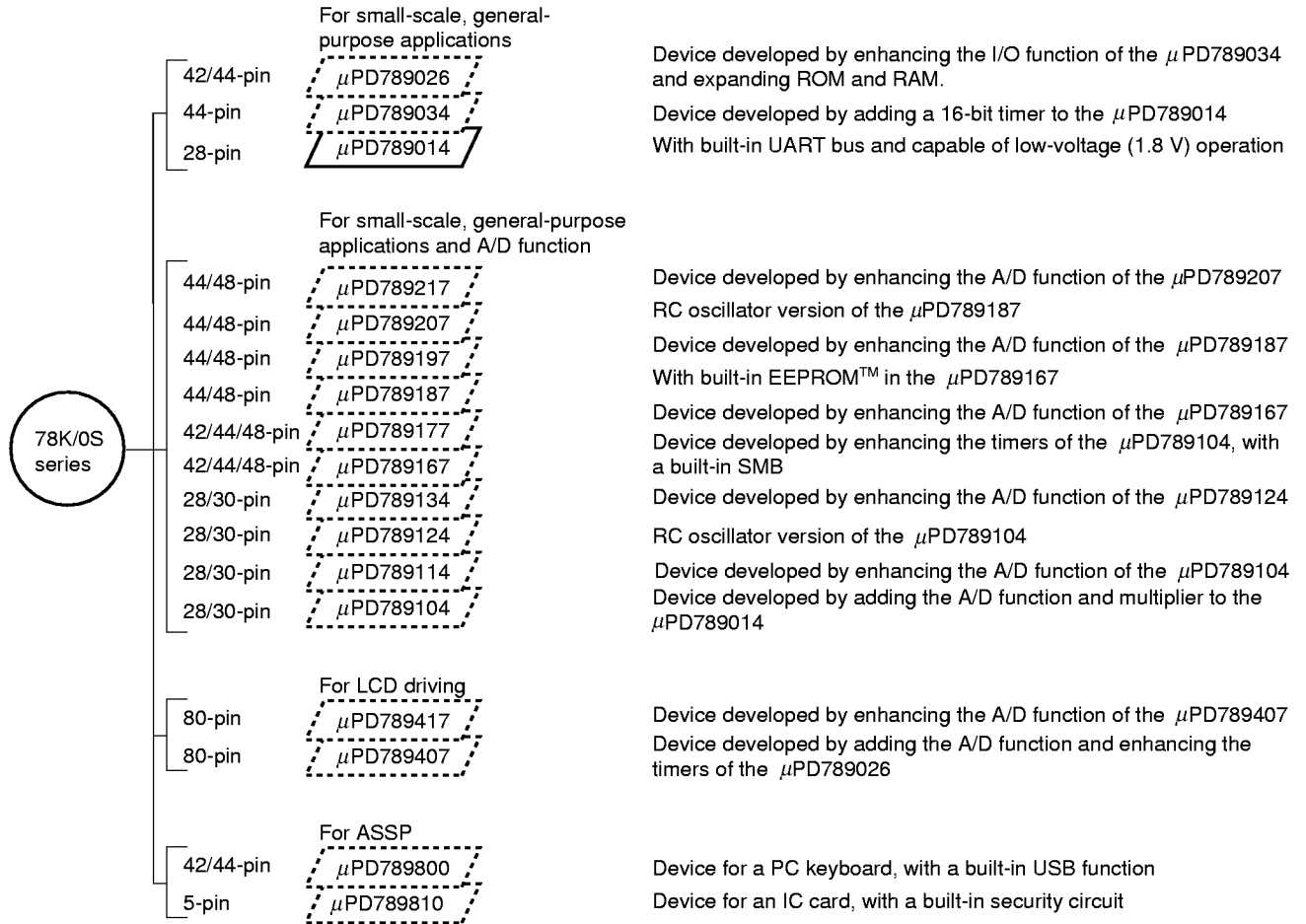
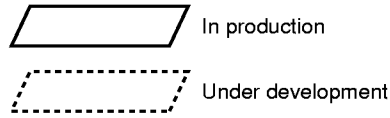

The following table lists the major differences in functions between the sub-series.

Sub-series	Function	ROM size	Timer				8-bit A/D	10-bit A/D	Serial interface	I/O	Minimum V _{DD} value	Remarks
			8-bit	16-bit	Clock	WDT						
Small-scale general purpose	μPD789026	4 K-16 K	1 ch	1 ch	-	1 ch	-	-	1 ch (UART: 1 ch)	34 pins	1.8 V	-
	μPD789034	2 K-4 K	-							28 pins		
	μPD789014	2 K-4 K	2 ch	-						22 pins		
Small-scale, general-purpose applications and A/D function	μPD789217	16 K-24 K	3 ch	1 ch	1 ch	1 ch	-	8 ch	2 ch UART : 1 ch SMB : 1 ch	31 pins	1.8 V	RC-oscillator version, with built-in EEPROM
	μPD789207						8 ch	-				
	μPD789197						-	8 ch				
	μPD789187						8 ch	-				
	μPD789177						-	8 ch				
	μPD789167						8 ch	-				
	μPD789134	2 K-8 K	1 ch				-	4 ch	1 ch (UART: 1 ch)	20 pins	1.8 V	RC-oscillator version
	μPD789124						4 ch	-				
	μPD789114						-	4 ch				
μPD789104	4 ch						-					
LCD driving	μPD789417	12 K-24 K	3 ch	1 ch	1 ch	1 ch	-	7 ch	1 ch (UART: 1 ch)	43 pins	1.8 V	-
	μPD789407						7 ch	-				
ASSP	μPD789800	8 K	2 ch	-	-	1 ch	-	-	2 ch (USB: 1 ch)	31 pins	4.0 V	-
	μPD789810	6 K	-						-	1 pin	1.8 V	With built-in EEPROM

FUNCTIONS

Item		Function
Built-in memory	Flash memory	16 Kbytes
	High-speed RAM	256 bytes
Minimum instruction execution time		0.4/1.6 μs (operation with main system clock running at 5.0 MHz)
General-purpose registers		8 bits × 8 registers
Instruction set		<ul style="list-style-type: none"> • 16-bit operations • Bit manipulations (such as set, reset, and test)
Multiplier		8 bits × 2 = 16 bits
I/O ports		Total of 20 port pins <ul style="list-style-type: none"> • 4 CMOS input pins • 12 CMOS input/output pins • 4 N-channel open-drain pins (withstand voltage of 12 V)
A/D converters		Four channels with 10-bit resolution
Serial interface		<ul style="list-style-type: none"> • Switchable between three-wire serial I/O and UART modes
Timers		<ul style="list-style-type: none"> • 16-bit timer 20 • 8-bit timer/event counter 80 • Watchdog timer
Timer output		One output
Vectored interrupt sources	Maskable	6 internal and 3 external interrupts
	Non-maskable	Internal interrupt
Power supply voltage		V _{DD} = 1.8 to 5.5 V
Operating ambient temperature		T _A = -40 to +85 °C
Package		<ul style="list-style-type: none"> • 28-pin plastic shrink DIP (400 mil) • 30-pin plastic shrink SOP (300 mil)

CONTENTS

1. PIN CONFIGURATION (TOP VIEW) 6

2. BLOCK DIAGRAM 8

3. DIFFERENCES BETWEEN THE μPD78F9116 AND MASKED ROM PRODUCTS 9

4. PIN FUNCTIONS 10

 4.1 Port Pins 10

 4.2 Non-Port Pins 11

 4.3 Pin Input/Output Circuits and Handling of Unused Pins 12

5. MEMORY SPACE 14

6. FLASH MEMORY PROGRAMMING 15

 6.1 Selecting the Transmission Method 15

 6.2 Flash Memory Programming Functions 16

 6.3 Connecting the Flashpro II 16

 6.4 Settings for the Flashpro II 18

7. INSTRUCTION SET 19

8. ELECTRICAL CHARACTERISTICS 22

9. PACKAGE DRAWINGS 34

APPENDIX A DEVELOPMENT TOOLS 36

APPENDIX B RELATED DOCUMENTS 37

1. PIN CONFIGURATION (TOP VIEW)

- 28-pin plastic shrink DIP (400 mil)
μPD78F9116CT

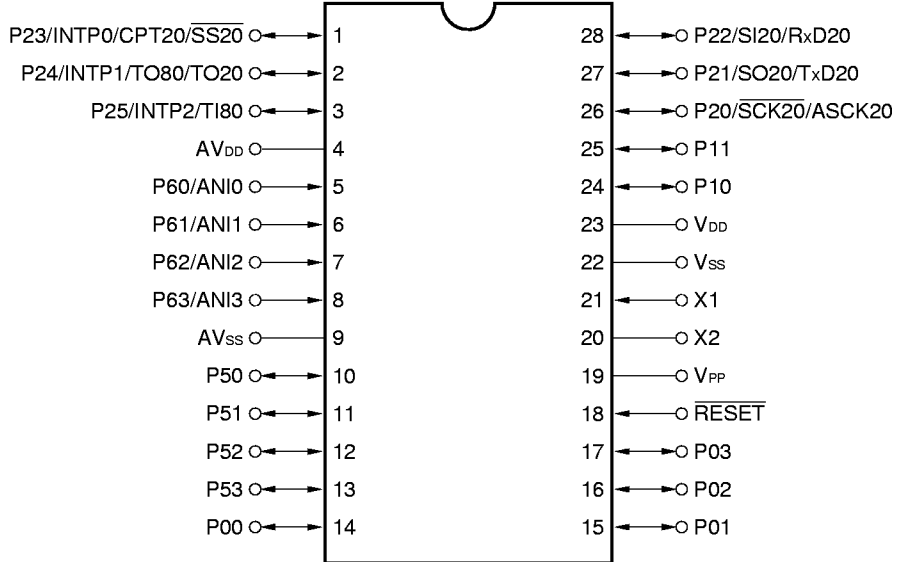

- Cautions**
1. Connect the V_{PP} pin directly to the V_{SS} pin.
 2. Connect the AV_{DD} pin to the V_{DD} pin.
 3. Connect the AV_{SS} pin to the V_{SS} pin.

- 30-pin plastic shrink SOP (300 mil)
μPD78F9116GS

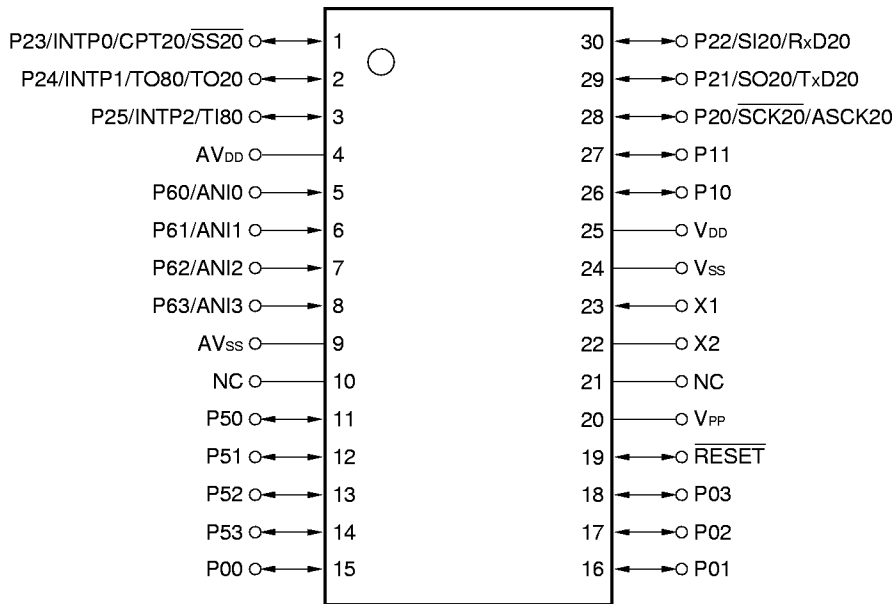

- Cautions**
1. Connect the V_{PP} pin directly to the V_{SS} pin.
 2. Connect the AV_{DD} pin to the V_{DD} pin.
 3. Connect the AV_{SS} pin to the V_{SS} pin.

ANI0-ANI3	: Analog Input	$\overline{\text{RESET}}$: Reset
ASCK20	: Asynchronous Serial Input	RxD20	: Receive Data
AV _{DD}	: Analog Power Supply	$\overline{\text{SCK20}}$: Serial Clock
AV _{SS}	: Analog Ground	SI20	: Serial Input
CPT20	: Capture Trigger Input	SO20	: Serial Output
INTP0-INTP2	: Interrupt from Peripherals	$\overline{\text{SS20}}$: Chip Select Input
NC	: Non-connection	TI80	: Timer Input
P00-P03	: Port0	TO20, TO80	: Timer Output
P10, P11	: Port1	TxD20	: Transmit Data
P20-P25	: Port2	V _{DD}	: Power Supply
P50-P53	: Port5	V _{PP}	: Programming Power Supply
P60-P63	: Port6	V _{SS}	: Ground
		X1, X2	: Crystal 1, 2

2. BLOCK DIAGRAM

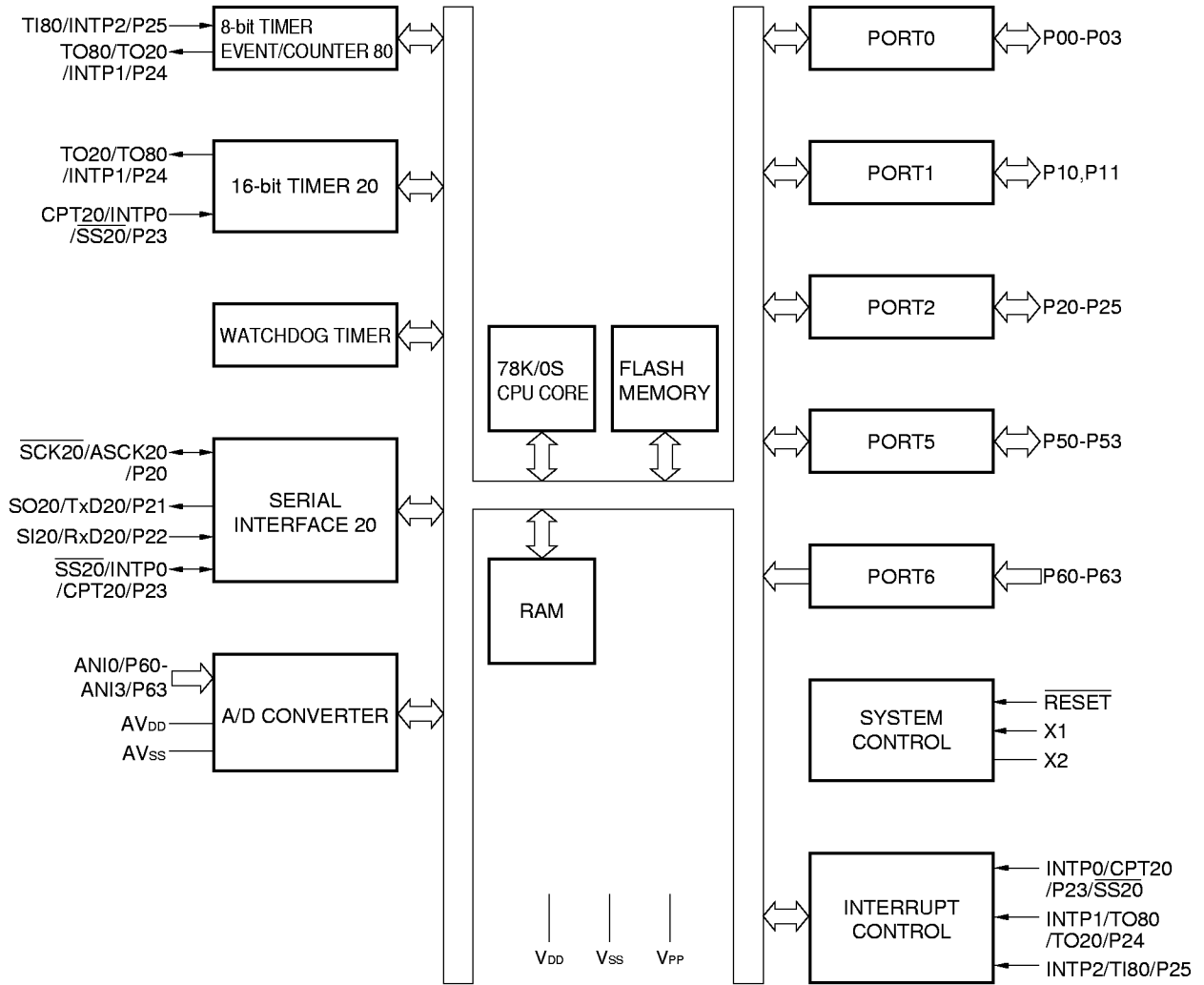

3. DIFFERENCES BETWEEN THE μPD78F9116 AND MASKED ROM PRODUCTS

The μPD78F9116 is produced by replacing the internal ROM of the masked ROM product with flash memory. Table 3-1 lists the differences between the μPD78F9116 and masked ROM products.

Table 3-1. Differences between the μPD78F9116 and Masked ROM Products

Item		Flash memory product	Masked ROM product		
		μPD78F9116	μPD789111	μPD789112	μPD789114
Internal memory	ROM	16 Kbytes	2 Kbytes	4 Kbytes	8 Kbytes
	High-speed RAM	256 bytes			
IC pin		Not provided	Provided		
V _{PP} pin		Provided	Not provided		
Electrical characteristics		May differ between the flash memory product and masked ROM products.			

4. PIN FUNCTIONS

4.1 Port Pins

Pin name	I/O	Function	When reset	Also used as
P00-P03	I/O	Port 0 4-bit input/output port Can be set to either input or output in 1-bit units When used as an input port, whether the built-in pull-up resistor is to be used can be specified by software.	Input	-
P10, P11	I/O	Port 1 2-bit input/output port Can be set to either input or output in 1-bit units When used as an input port, whether the built-in pull-up resistor is to be used can be specified by software.	Input	-
P20	I/O	Port 2 6-bit input/output port Can be set to either input or output in 1-bit units When used as an input port, whether the built-in pull-up resistor is to be used can be specified by software.	Input	SCK20/ASCK20
P21				SO20/TxD20
P22				SI20/RxD20
P23				INTP0/CPT20 /SS20
P24				INTP1/TO80/TO20
P25				INTP2/TI80
P50-P53	I/O	Port 5 4-bit N-ch open-drain input/output port Can be set to either input or output in 1-bit units	Input	-
P60-P63	Input	Port 6 4-bit input-only port	Input	ANI0-ANI3

4.2 Non-Port Pins

Pin name	I/O	Function	When reset	Also used as
INTP0	Input	External interrupt input for which effective edges (rising and/or falling edges) can be specified	Input	P23/CPT20/SS20
INTP1				P24/TO80/TO20
INTP2				P25/TI80
SI20	Input	Serial data input to serial interface	Input	P22/RxD20
SO20	Output	Serial data output from serial interface	Input	P21/TxD20
SCK20	I/O	Serial clock input/output for serial interface	Input	P20/ASCK20
ASCK20	Input	Serial clock input to asynchronous serial interface	Input	P20/SCK20
SS20	Input	Chip select input to serial interface	Input	P23/CPT20/INTP0
RxD20	Input	Serial data input to asynchronous serial interface	Input	P22/SI20
TxD20	Output	Serial data output from asynchronous serial interface	Input	P21/SO20
TI80	Input	External count clock input to 8-bit timer (TM80)	Input	P25/INTP2
TO80	Output	8-bit timer (TM80) output	Input	P24/INTP1/TO20
TO20	Output	16-bit timer (TM20) output	Input	P24/INTP1/TO80
CPT20	Input	Capture edge input	Input	P23/INTP0/SS20
ANI0-ANI3	Input	A/D converter analog input	Input	P60-P63
AV _{SS}	-	A/D converter ground potential	-	-
AV _{DD}	-	A/D converter analog power supply	-	-
X1	Input	Connected to crystal for main system clock oscillation	-	-
X2	-		-	-
RESET	Input	System reset input	Input	-
V _{DD}	-	Positive supply voltage	-	-
V _{SS}	-	Ground potential	-	-
V _{PP}	-	Pin for setting flash memory programming mode. Apply a high voltage to write or verify a program. In normal operation mode, connect the V _{PP} pin directly to the V _{SS} pin.	-	-

4.3 Pin Input/Output Circuits and Handling of Unused Pins

Table 4-1 lists the types of input/output circuits for each pin and explains how unused pins are handled. Figure 4-1 shows the configuration of each type of input/output circuit.

Table 4-1. Type of Input/Output Circuit for Each Pin and Handling of Unused Pins

Pin name	I/O circuit type	I/O	Recommended connection of unused pins
P00-P03	5-A	I/O	Connect these pins to the V _{DD} or V _{SS} pin through a separate resistor.
P10, P11			
P20/ $\overline{\text{SCK20}}$ /ASCK20	8-A		Connect these pins to the V _{SS} pin through a separate resistor.
P21/SO20/TxD20			
P22/SI20/RxD20			
P23/INTP0/CPT20/ $\overline{\text{SS20}}$			
P24/INTP1/TO80/TO20			
P25/INTP2/TI80			
P50-P53	13-V		Connect these pins to the V _{DD} pin through a separate resistor.
P60/ANI0-P63/ANI3	9-C	Input	Connect these pins to the V _{DD} or V _{SS} pin through a separate resistor.
AV _{DD}	-	-	Connect this pin to the V _{DD} pin through a resistor.
AV _{SS}	-	-	Connect this pin to the V _{SS} pin through a resistor.
$\overline{\text{RESET}}$	2	Input	-
V _{PP}	-	-	Connect this pin directly to the V _{SS} pin.

Figure 4-1. Pin Input/Output Circuits

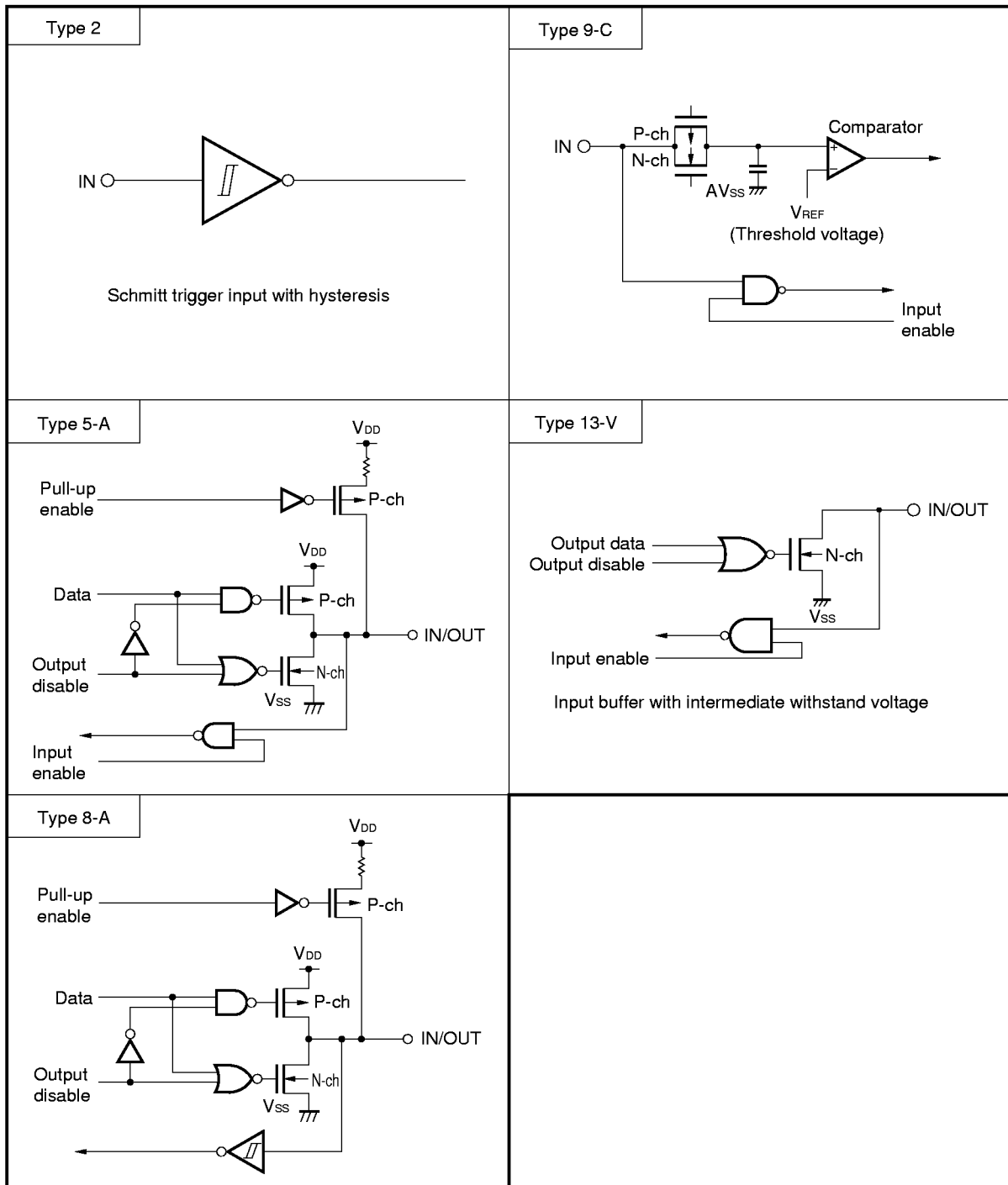

5. MEMORY SPACE

Figure 5-1 shows the memory map of the μPD78F9116.

Figure 5-1. Memory Map

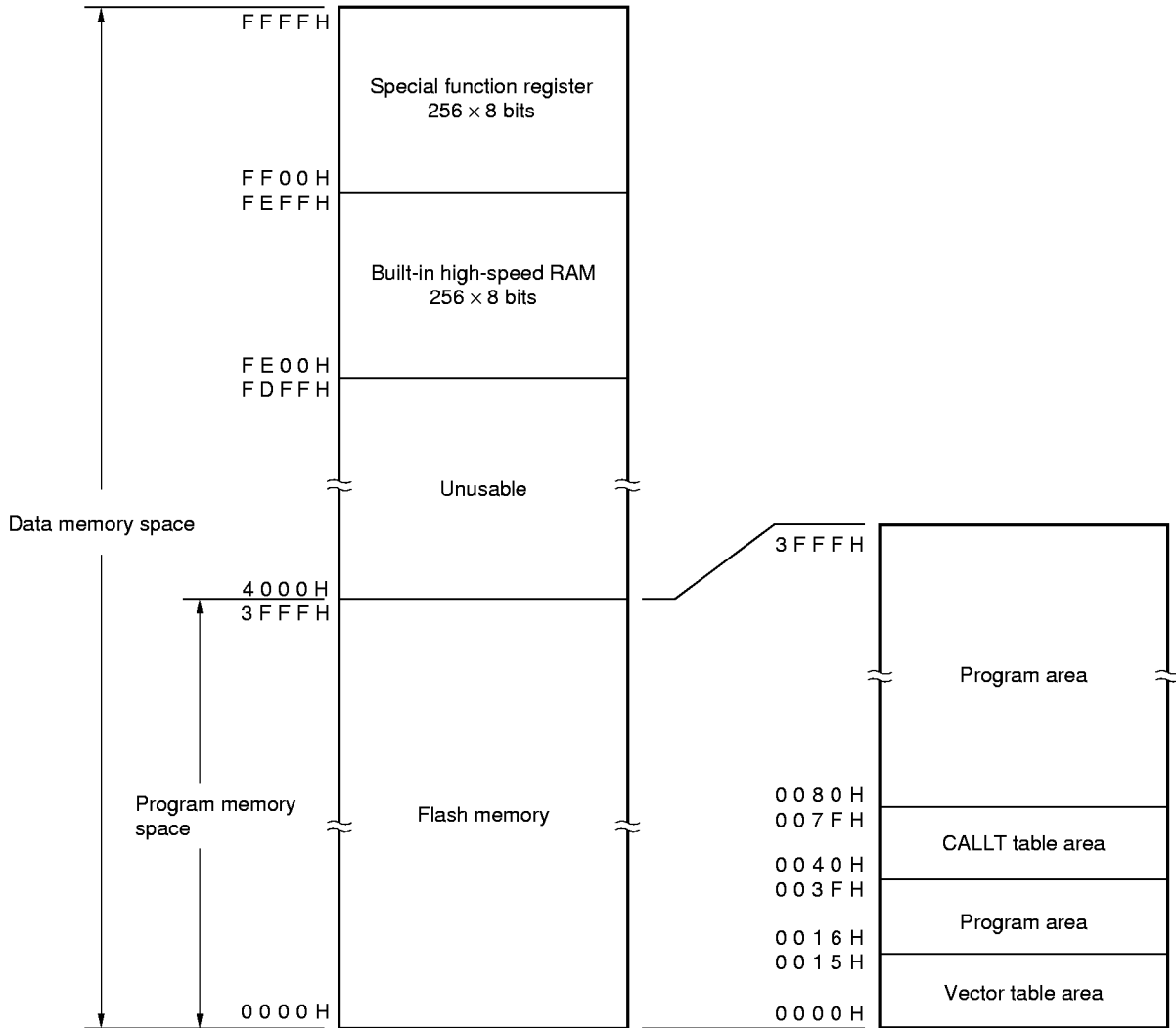

6. FLASH MEMORY PROGRAMMING

Flash memory is used as the built-in program memory of the μPD78F9116.

The flash memory can be written even while the device is mounted in the target system (on-board write). To write a program into the flash memory, connect the dedicated flash writer (Flashpro II (Model number: FL-PRII)) to both the host machine and target system.

Remark The Flashpro II (formerly, Flashpro) is manufactured by Naito Densai Machida Mfg. Co., Ltd.

6.1 Selecting the Transmission Method

The Flashpro II writes into flash memory by means of serial transmission. The transmission method to be used for writing is selected from those listed in Table 6-1. To select a transmission method, use the format shown in Figure 6-1, according to the number of V_{PP} pulses listed in Table 6-1.

Table 6-1. Transmission Methods

Transmission method	Pins	Number of V _{PP} pulses
3-wire serial I/O	$\overline{\text{SCK20}}/\text{ASCK20}/\text{P20}$ SO20/TxD20/P21 SI20/RxD20/P22	0
UART	TxD20/SO20/P21 RxD20/SI20/P22	8
Pseudo 3-wire mode ^{Note}	P00 (serial clock input) P01 (serial data input) P02 (serial data output)	12

Note Serial transfer by controlling the ports using software

Caution To select a transmission method, always use the corresponding number of V_{PP} pulses listed in Table 6-1.

Figure 6-1. Transmission Method Selection Format

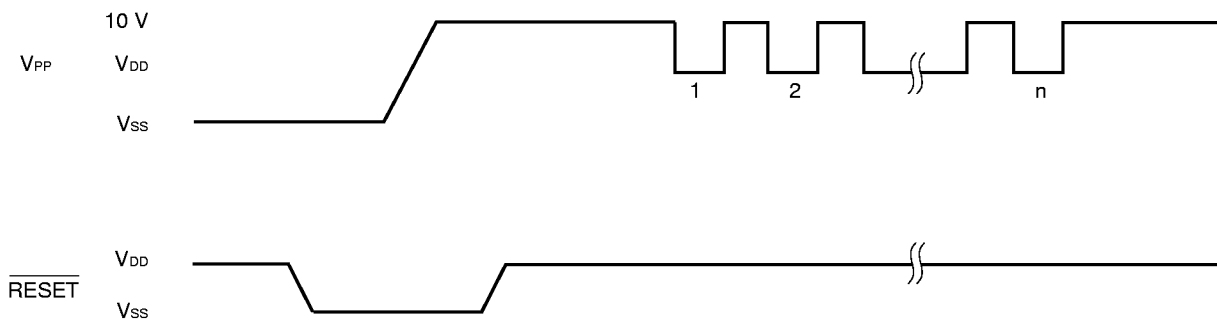

6.2 Flash Memory Programming Functions

Flash memory writing and other operations can be performed by transmitting/receiving commands and data according to the selected transmission method. Table 6-2 lists the main flash memory programming functions.

Table 6-2. Main Flash Memory Programming Functions

Function	Description
Batch erase	Erases the entire contents of memory.
Batch blank check	Checks that the entire contents of memory have been erased.
Data write	Write to the flash memory according to the specified write start address and number of bytes of data to be written.
Batch verify	Compares the entire contents of memory with the input data.

6.3 Connecting the Flashpro II

The connection between the Flashpro II and μPD78F9116 varies with the transmission method (3-wire serial I/O, UART, or pseudo 3-wire). Figures 6-2 to 6-4 show the connection for each transmission method.

Figure 6-2. Flashpro II Connection in 3-Wire Serial I/O Mode

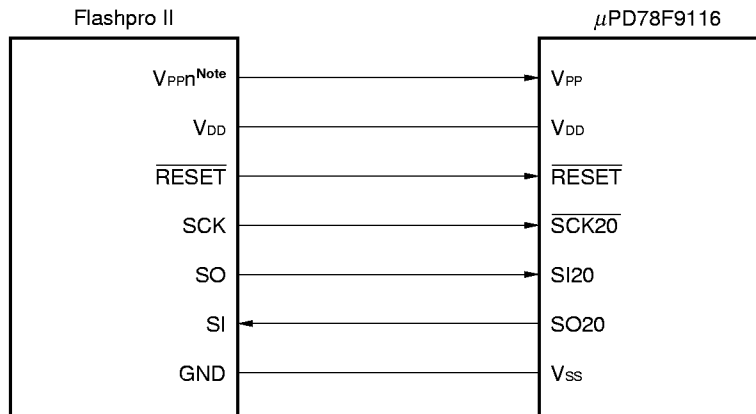

Note n: 1 or 2

Figure 6-3. Flashpro II Connection in UART Mode

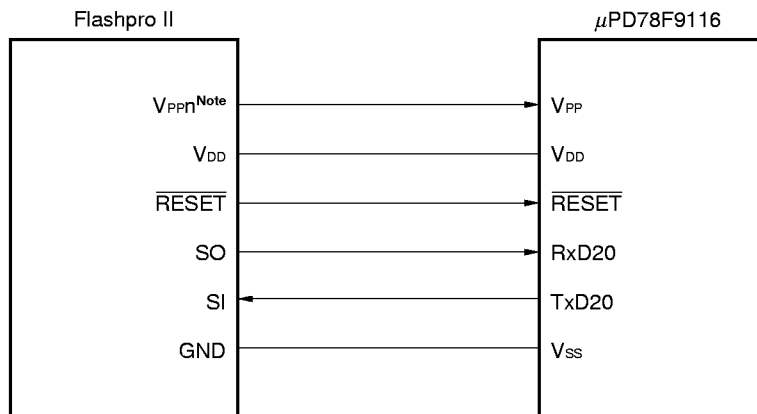

Note n: 1 or 2

Figure 6-4. Flashpro II Connection in Pseudo 3-Wire Mode (When P0 Is Used)

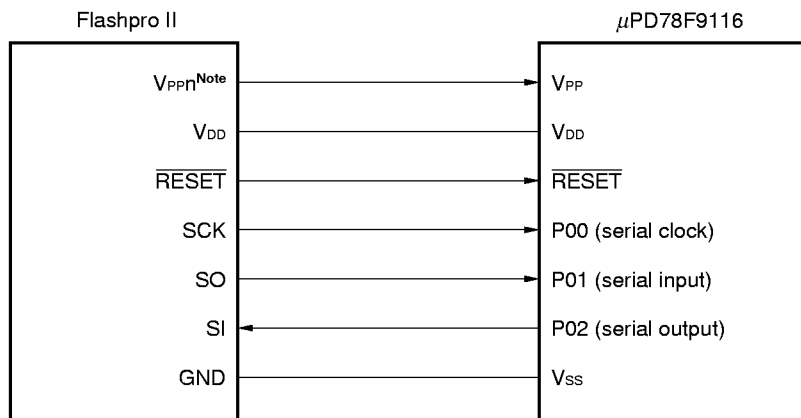

Note n: 1 or 2

6.4 Settings for the Flashpro II

When using the Flashpro II to write to flash memory, set the Flashpro II as listed in Table 6-3.

Table 6-3. Settings for the Flashpro II

Transmission method	Settings for the Flashpro II		Number of V _{PP} pulses ^{Note 1}
3-wire serial I/O	Type	78K (2)	0
	ROM	Flash	
	START ADDRESS	0	
	END ADDRESS	3FFF	
	COMM PORT	SIO ch-0	
	SIO CLK	100 kHz	
	CPU CLK	In Flashpro	
	Flashpro CLK	3.125 MHz	
	RAM	128	
UART	Type	78K (2)	8
	ROM	Flash	
	START ADDRESS	0	
	END ADDRESS	3FFF	
	COMM PORT	UART ch-0	
	UART BPS	9 600 bps ^{Note 2}	
	CPU CLK	On Target Board	
	Target Board CLK	5.0 MHz	
	RAM	128	
Pseudo 3-wire mode	Type	78K (2)	12
	ROM	Flash	
	START ADDRESS	0	
	END ADDRESS	3FFF	
	COMM PORT	Port A	
	SIO CLK	1 kHz	
	CPU CLK	In Flashpro	
	Flashpro CLK	1.562 MHz	
	RAM	128	

- Notes**
1. Number of V_{PP} pulses supplied from the Flashpro II during initialization of serial transmission. Pins to be used in transmission depend on this number.
 2. Select one of the following: 9 600, 19 200, 38 400, or 76 800 bps.

Remark

- COMM PORT : Selection of the serial port
- SIO CLK : Selection of the serial clock frequency
- CPU CLK : Selection of the input CPU clock source

7. INSTRUCTION SET

(1) 8-bit instructions

MOV, XCH, ADD, ADDC, SUB, SUBC, AND, OR, XOR, CMP, INC, DEC, ROR, ROL, RORC, ROLC, PUSH, POP, DBNZ

2nd operand 1st operand	#byte	A	r	sfr	saddr	laddr16	PSW	[DE]	[HL]	[HL + byte]	\$addr16	1	None
A	ADD ADDC SUB SUBC AND OR XOR CMP		MOV ^{Note} XCH ^{Note} ADD ADDC SUB SUBC AND OR XOR CMP	MOV XCH	MOV XCH ADD ADDC SUB SUBC AND OR XOR CMP	MOV XCH ADD ADDC SUB SUBC AND OR XOR CMP	MOV	MOV XCH	MOV XCH ADD ADDC SUB SUBC AND OR XOR CMP	MOV XCH ADD ADDC SUB SUBC AND OR XOR CMP		ROR ROL RORC ROLC	
r	MOV	MOV ^{Note}											INC DEC
B, C											DBNZ		
sfr	MOV	MOV											
saddr	MOV ADD ADDC SUB SUBC AND OR XOR CMP	MOV									DBNZ		INC DEC
laddr16		MOV											
PSW	MOV	MOV											PUSH POP
[DE]		MOV											
[HL]		MOV											
[HL + byte]		MOV											

Note Except r = A

(2) 16-bit instructions

MOVW, XCHW, ADDW, SUBW, CMPW, PUSH, POP, INCW, DECW

2nd operand 1st operand	#word	AX	rp ^{Note}	saddrp	SP	None
AX	ADDW SUBW CMPW		MOVW XCHW	MOVW	MOVW	
rp	MOVW	MOVW ^{Note}				INCW DECW PUSH POP
saddrp		MOVW				
SP		MOVW				

Note Only when rp = BC, DE, HL

(3) Bit manipulation instructions

SET1, CLR1, NOT1, BT, BF

2nd operand 1st operand	\$addr16	None
A.bit	BT BF	SET1 CLR1
sfr.bit	BT BF	SET1 CLR1
saddr.bit	BT BF	SET1 CLR1
PSW.bit	BT BF	SET1 CLR1
[HL].bit		SET1 CLR1
CY		SET1 CLR1 NOT1

(4) Call instructions/ branch instructions

CALL, CALLT, BR, BC, BNC, BZ, BNZ, BT, BF, DBNZ

2nd operand 1st operand	AX	!addr16	[addr5]	\$addr16
Basic instruction	BR	CALL BR	CALLT	BR BC BNC BZ BNZ
Complex instruction				DBNZ

(5) Other instructions

RET, RETI, NOP, EI, DI, HALT, STOP

8. ELECTRICAL CHARACTERISTICS

ABSOLUTE MAXIMUM RATINGS (T_A = 25 °C)

Parameter	Symbol	Conditions	Rated value	Unit
Supply voltage	V _{DD}		-0.5 to +6.5	V
	V _{PP}		-0.5 to +10.5	V
Input voltage	V _{I1}	Pins other than P50-P53	-0.3 to V _{DD} + 0.3	V
	V _{I2}	P50-P53 (N-ch open drain)	-0.3 to +13	V
Output voltage	V _O		-0.3 to V _{DD} + 0.3	V
High-level output current	I _{OH}	Each pin	-10	mA
		Total for all pins	-30	mA
Low-level output current	I _{OL}	Each pin	30	mA
		Total for all pins	160	mA
Operating ambient temperature	T _A		-40 to +85	°C
Storage temperature	T _{stg}		-40 to +125	°C

Caution Absolute maximum ratings are rated values beyond which physical damage will be caused to the product; if the rated value of any of the parameters in the above table is exceeded, even momentarily, the quality of the product may deteriorate. Always use the product within its rated values.

Remark The characteristic of a dual-function pin does not differ between the port function and the secondary function, unless otherwise stated.

CHARACTERISTICS OF THE MAIN SYSTEM CLOCK OSCILLATION CIRCUIT

(T_A = -40 to +85 °C, V_{DD} = 1.8 to 5.5 V)

Resonator	Recommended circuit	Parameter	Conditions	MIN.	TYP.	MAX.	Unit
Ceramic resonator		Oscillator frequency (f _x) ^{Note 1}	V _{DD} = oscillation voltage range	1.0		5.0	MHz
		Oscillation settling time ^{Notes 2, 3}	Release by RESET		2 ¹⁵ /f _x		ms
			Release by an interrupt		Note 4		ms
Crystal		Oscillator frequency (f _x) ^{Note 1}		1.0		5.0	MHz
		Oscillation settling time ^{Note 2}	V _{DD} = 4.5 to 5.5 V			10	ms
						30	
External clock		X1 input frequency (f _x) ^{Note 1}		1.0		5.0	MHz
		X1 input high/low level width (t _{xH} , t _{xL})		85		500	ns

- Notes**
1. Only the characteristic of the oscillation circuit is indicated. See the description of the AC characteristic for the instruction execution time.
 2. Time required for oscillation to settle once a reset sequence ends or STOP mode is deselected.
 3. Time after V_{DD} reaches MIN. of the oscillation voltage range.
 4. Selectable between 2¹²/f_x, 2¹⁵/f_x, and 2¹⁷/f_x with bits 0 to 2 (OSTS0-OSTS2) of the oscillation settling time selection register.

Caution When using the main system clock oscillation circuit, observe the following conditions for the wiring of that section enclosed in dotted lines in the above diagrams, so as to avoid the influence of the wiring capacitance.

- Keep the wiring as short as possible.
- Do not allow signal wires to cross one another.
- Keep the wiring away from wires that carry a high, non-stable current.
- Keep the grounding point of the capacitors at the same level as V_{SS}.
- Do not connect the grounding point to a grounding wire that carries a high current.
- Do not extract a signal from the oscillation circuit.

DC CHARACTERISTICS (T_A = -40 to +85 °C, V_{DD} = 1.8 to 5.5 V)

Parameter	Symbol	Conditions		MIN.	TYP.	MAX.	Unit	
Low-level output current	I _{OL}	Each pin				Undefined	mA	
		Total for all pins				80	mA	
High-level output current	I _{OH}	Each pin				Undefined	mA	
		Total for all pins				-15	mA	
High-level input voltage	V _{IH1}	P00-P03, P10, P11, P60-P63	V _{DD} = 2.7 to 5.5 V	0.7V _{DD}		V _{DD}	V	
				0.9V _{DD}		V _{DD}	V	
	V _{IH2}	P50-P53 (N-ch open drain)	V _{DD} = 2.7 to 5.5 V	0.7V _{DD}		12	V	
				0.9V _{DD}		12	V	
	V _{IH3}	RESET, P20-P25, P40-P45	V _{DD} = 2.7 to 5.5 V	0.8V _{DD}		V _{DD}	V	
			0.9V _{DD}		V _{DD}	V		
V _{IH4}	X1, X2		V _{DD} - 0.1		V _{DD}	V		
Low-level input voltage	V _{IL1}	P00-P03, P10, P11, P60-P63	V _{DD} = 2.7 to 5.5 V	0		0.3V _{DD}	V	
				0		0.1V _{DD}	V	
	V _{IL2}	P50-P53	V _{DD} = 2.7 to 5.5 V	0		0.3V _{DD}	V	
				0		0.1V _{DD}	V	
	V _{IL3}	RESET, P20-P25, P40-P45	V _{DD} = 2.7 to 5.5 V	0		0.2V _{DD}	V	
			0		0.1V _{DD}	V		
V _{IL4}	X1, X2		0		0.1	V		
High-level output voltage	V _{OH}	V _{DD} = 4.5 to 5.5 V, I _{OH} = -1 mA		V _{DD} - 1.0			V	
		V _{DD} = 1.8 to 5.5 V, I _{OH} = -100 μA		V _{DD} - 0.5			V	
Low-level output voltage	V _{OL1}	Pins other than P50-P53	V _{DD} = 4.5 to 5.5 V, I _{OL} = 10 mA			1.0	V	
			V _{DD} = 1.8 to 5.5 V, I _{OL} = 400 μA			0.5	V	
	V _{OL2}	P50-P53	V _{DD} = 4.5 to 5.5 V, I _{OL} = 10 mA			1.0	V	
			V _{DD} = 1.8 to 5.5 V, I _{OL} = 1.6 mA			0.4	V	
High-level input leakage current	I _{LIH1}	V _{IN} = V _{DD}	Pins other than P50-P53, X1, or X2			3	μA	
	I _{LIH2}			X1, X2			20	μA
	I _{LIH3}	V _{IN} = 12 V	P50-P53 (N-ch open drain)			20	μA	
Low-level input leakage current	I _{LIL1}	V _{IN} = 0 V	Pins other than P50-P53, X1, or X2			-3	μA	
				X1, X2			-20	μA
	I _{LIL3}		P50-P53 (N-ch open drain) When input instruction is not executed				-3	μA
				P50-P53 (N-ch open drain) During input instruction execution			-30	μA
High-level output leakage current	I _{LOH}	V _{OUT} = V _{DD}				3	μA	
Low-level output leakage current	I _{LOL}	V _{OUT} = 0 V				-3	μA	

Remark The characteristic of a dual-function pin does not differ between the port function and the secondary function, unless otherwise stated.

DC CHARACTERISTICS ($T_A = -40$ to $+85$ °C, $V_{DD} = 1.8$ to 5.5 V)

Parameter	Symbol	Conditions	MIN.	TYP.	MAX.	Unit	
Software-specified pull-up resistor	R ₁	$V_{IN} = 0$ V, for pins other than P50-P53	50	100	200	kΩ	
Power supply current ^{Note 1}	I _{DD1}		$V_{DD} = 5.0$ V ± 10 % ^{Note 2}		5.0	15.0	mA
			$V_{DD} = 3.0$ V ± 10 % ^{Note 3}		1.9	4.9	mA
			$V_{DD} = 2.0$ V ± 10 % ^{Note 3}		0.9	2.3	mA
	I _{DD2}	5.0-MHz crystal oscillation HALT mode	$V_{DD} = 5.0$ V ± 10 % ^{Note 2}		1.2	3.6	mA
			$V_{DD} = 3.0$ V ± 10 % ^{Note 3}		0.5	1.5	mA
			$V_{DD} = 2.0$ V ± 10 % ^{Note 3}		0.3	0.9	mA
	I _{DD3}	STOP mode	$V_{DD} = 5.0$ V ± 10 %		0.1	30	μA
			$V_{DD} = 3.0$ V ± 10 %		0.05	10	μA
			$V_{DD} = 2.0$ V ± 10 %		0.05	10	μA
	I _{DD4}	5.0-MHz crystal oscillation A/D operating mode	$V_{DD} = 5.0$ V ± 10 %		5.6	16.8	mA
			$V_{DD} = 3.0$ V ± 10 %		2.5	10.9	mA
			$V_{DD} = 2.0$ V ± 10 %		1.5	8.3	mA

- Notes**
1. The power supply current does not include AV_{DD} or the port current (including the current flowing through the built-in pull-up resistor).
 2. During high-speed mode operation (when the processor clock control register (PCC) is cleared to 00H)
 3. During low-speed mode operation (when the PCC is set to 02H)

Remark The characteristic of a dual-function pin does not differ between the port function and the secondary function, unless otherwise stated.

AC CHARACTERISTICS

(1) Basic operations (T_A = -40 to +85 °C, V_{DD} = 1.8 to 5.5 V)

Parameter	Symbol	Conditions	MIN.	TYP.	MAX.	Unit
Cycle time (minimum instruction execution time)	T _{CY}	V _{DD} = 2.7 to 5.5 V	0.4		8	μs
			1.6		8	μs
T180 input high/low level width	t _{TIH}	V _{DD} = 2.7 to 5.5 V	0.1			μs
	t _{TIL}		1.8			μs
T180 input frequency	f _{TI}	V _{DD} = 2.7 to 5.5 V	0		4	MHz
			0		275	kHz
Interrupt input high/low level width	t _{INTH}	INTP0-INTP2	V _{DD} = 2.7 to 5.5 V	10		μs
	t _{INTL}			20		μs
RESET low level width	t _{RSL}	V _{DD} = 2.7 to 5.5 V	10			μs
			20			μs

T_{CY} vs V_{DD} (main system clock)

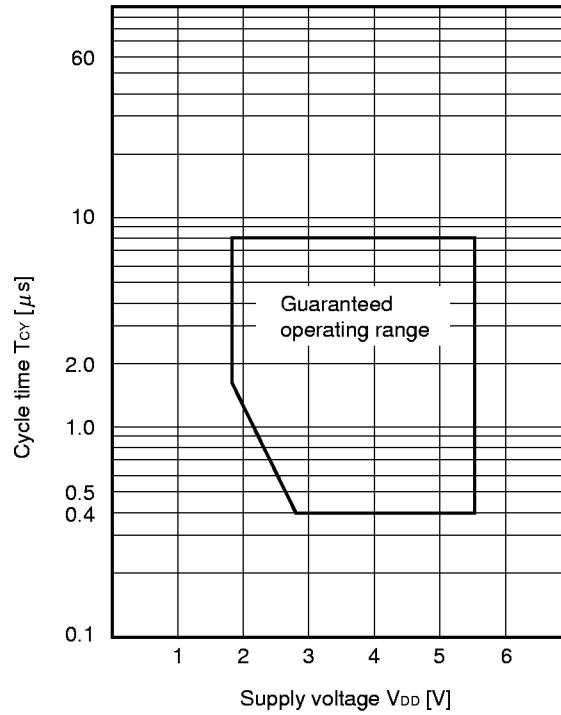

(2) Serial interface (T_A = -40 to +85 °C, V_{DD} = 1.8 to 5.5 V)

(i) Three-wire serial I/O mode (SCK20...Internal clock output)

Parameter	Symbol	Conditions	MIN.	TYP.	MAX.	Unit
SCK20 cycle time	t _{KCY1}	V _{DD} = 2.7 to 5.5 V	800			ns
			3 200			ns
SCK20 high/low level width	t _{KH1} , t _{KL1}	V _{DD} = 2.7 to 5.5 V	t _{KCY1} /2-50			ns
			t _{KCY1} /2-150			ns
SI20 setup time (for SCK20 latch edge)	t _{SIK1}	V _{DD} = 2.7 to 5.5 V	150			ns
			500			ns
SI20 hold time (for SCK20 latch edge)	t _{KSH1}	V _{DD} = 2.7 to 5.5 V	400			ns
			600			ns
Delay from SCK20 shift edge to SO20 output	t _{KSO1}	R = 1 kΩ, C = 100 pF ^{Note}	V _{DD} = 2.7 to 5.5 V	0	250	ns
				0	1 000	ns

Note R and C are the resistance and capacitance of the SO20 output line, respectively.

(ii) Three-wire serial I/O mode (SCK20...External clock output)

Parameter	Symbol	Conditions	MIN.	TYP.	MAX.	Unit
SCK20 cycle time	t _{KCY2}	V _{DD} = 2.7 to 5.5 V	800			ns
			3 200			ns
SCK20 high/low level width	t _{KH2} , t _{KL2}	V _{DD} = 2.7 to 5.5 V	400			ns
			1 600			ns
SI20 setup time (for SCK20 latch edge)	t _{SIK2}	V _{DD} = 2.7 to 5.5 V	100			ns
			150			ns
SI20 hold time (for SCK20 latch edge)	t _{KSI2}	V _{DD} = 2.7 to 5.5 V	400			ns
			600			ns
Delay from SCK20 shift edge to SO20 output	t _{KSO2}	R = 1 kΩ, C = 100 pF ^{Note}	V _{DD} = 2.7 to 5.5 V	0	300	ns
				0	1 000	ns
SO20 setup time (for SS20↓ when SS20 is used)	t _{KAS2}	V _{DD} = 2.7 to 5.5 V			120	ns
					400	ns
SO20 disable time (for SS20↑ when SS20 is used)	t _{KDS2}	V _{DD} = 2.7 to 5.5 V			240	ns
					800	ns

Note R and C are the resistance and capacitance of the SO20 output line, respectively.

(iii) UART mode (Internal clock output)

Parameter	Symbol	Conditions	MIN.	TYP.	MAX.	Unit
Transfer rate		V _{DD} = 2.7 to 5.5 V			78 125	bps
					19 531	bps

(iv) UART mode (external clock input)

Parameter	Symbol	Conditions	MIN.	TYP.	MAX.	Unit
ASCK20 cycle time	t _{KCY3}	V _{DD} = 2.7 to 5.5 V	800			ns
			3 200			ns
ASCK20 high/low level width	t _{KH3} , t _{KL3}	V _{DD} = 2.7 to 5.5 V	400			ns
			1 600			ns
Transfer rate		V _{DD} = 2.7 to 5.5 V			39 063	bps
					9 766	bps
ASCK20 rising time, falling time	t _R , t _F				1	μs

AC TIMING MEASUREMENT POINTS (except the X1 input)

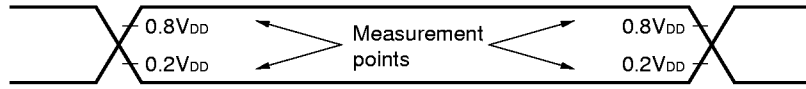

CLOCK TIMING

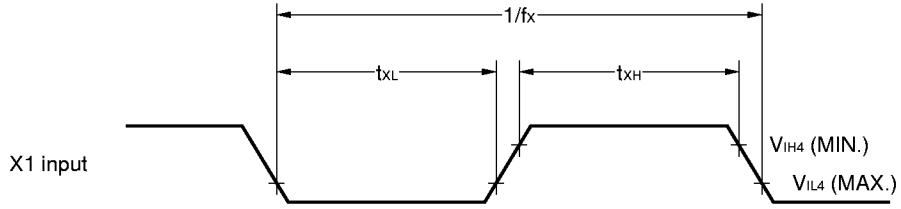

TI TIMING

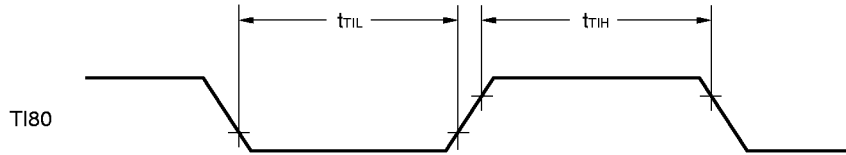

SERIAL TRANSFER TIMING

Three-Wire Serial I/O Mode:

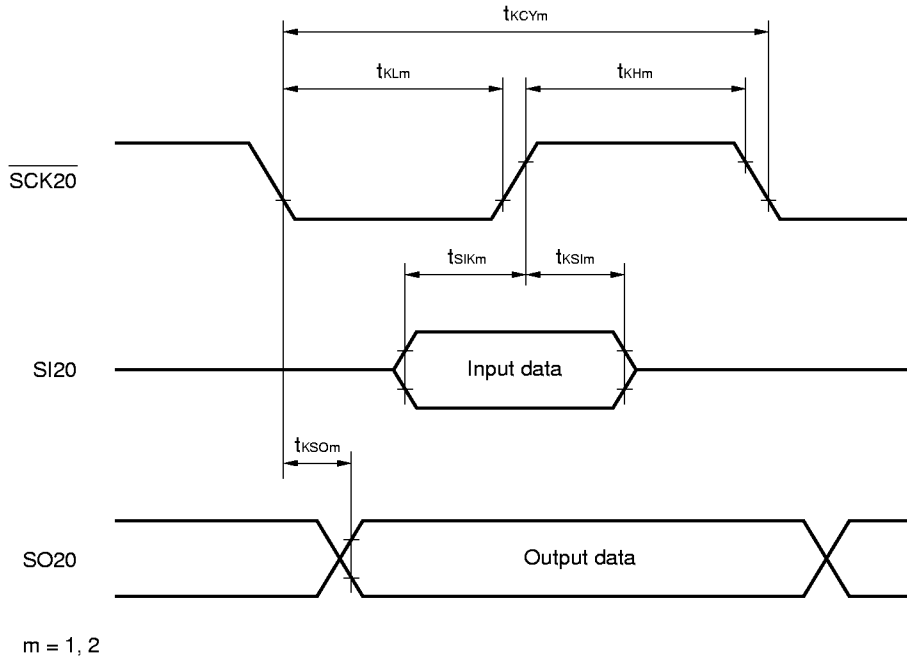

Three-Wire Serial I/O Mode (When $\overline{\text{SS20}}$ Is Used):

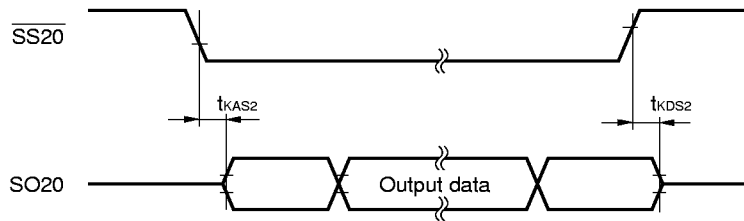

UART Mode (External Clock Input):

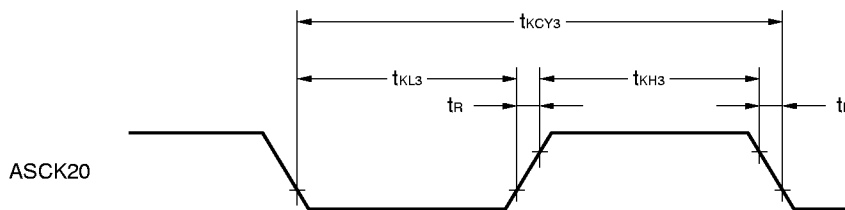

A/D CONVERTER CHARACTERISTICS (T_A = -40 to +85 °C, V_{DD} = 1.8 to 5.5 V)

Item	Symbol	Conditions	MIN.	TYP.	MAX.	Unit
Resolution			10	10	10	bit
Total error ^{Note}		4.5 V ≤ V _{DD} ≤ 5.5 V		0.2	0.4	%
		2.7 V ≤ V _{DD} < 4.5 V		0.4	0.7	
		1.8 V ≤ V _{DD} < 2.7 V		Undefined	Undefined	
Conversion time	t _{CONV}	4.5 V ≤ V _{DD} ≤ 5.5 V	Undefined		Undefined	μs
		2.7 V ≤ V _{DD} < 4.5 V	Undefined		Undefined	
		1.8 V ≤ V _{DD} < 2.7 V	Undefined		Undefined	
Analog input voltage	V _{IAN}		AV _{SS}		AV _{DD}	V

Note No quantization error (±1/2 LSB) is included.

DATA MEMORY STOP MODE LOW SUPPLY VOLTAGE DATA HOLD CHARACTERISTICS

(T_A = -40 to +85 °C)

Item	Symbol	Conditions	MIN.	TYP.	MAX.	Unit
Data hold supply voltage	V _{DDDR}		1.8		5.5	V
Release signal set time	t _{SREL}		0			μs

DATA HOLD TIMING (STOP mode release by RESET)

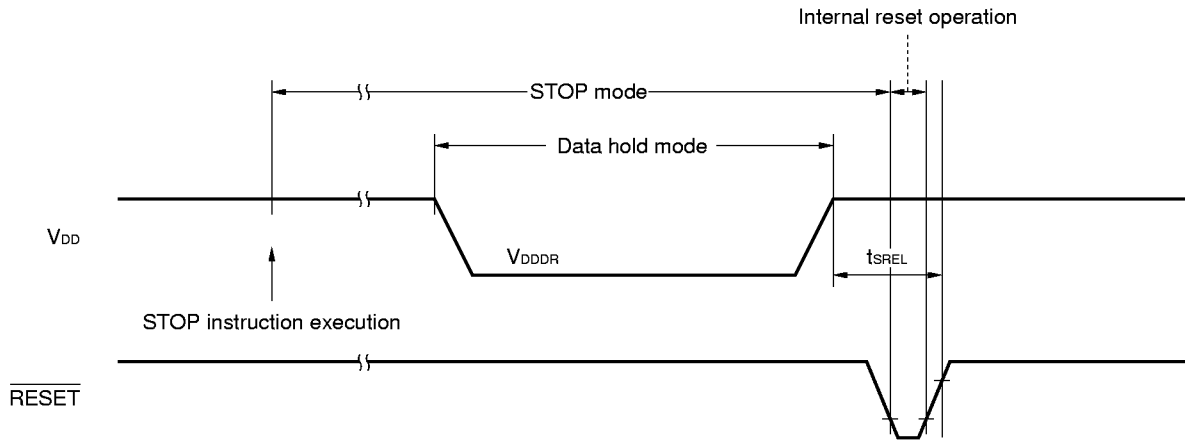

INTERRUPT INPUT TIMING

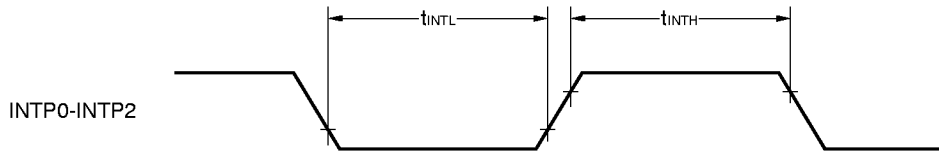

RESET INPUT TIMING

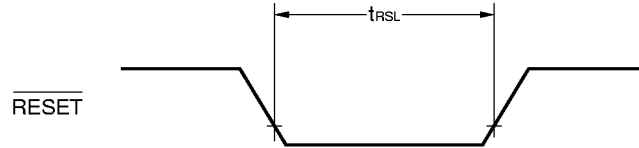

9. PACKAGE DRAWINGS

28PIN PLASTIC SHRINK DIP (400 mil)

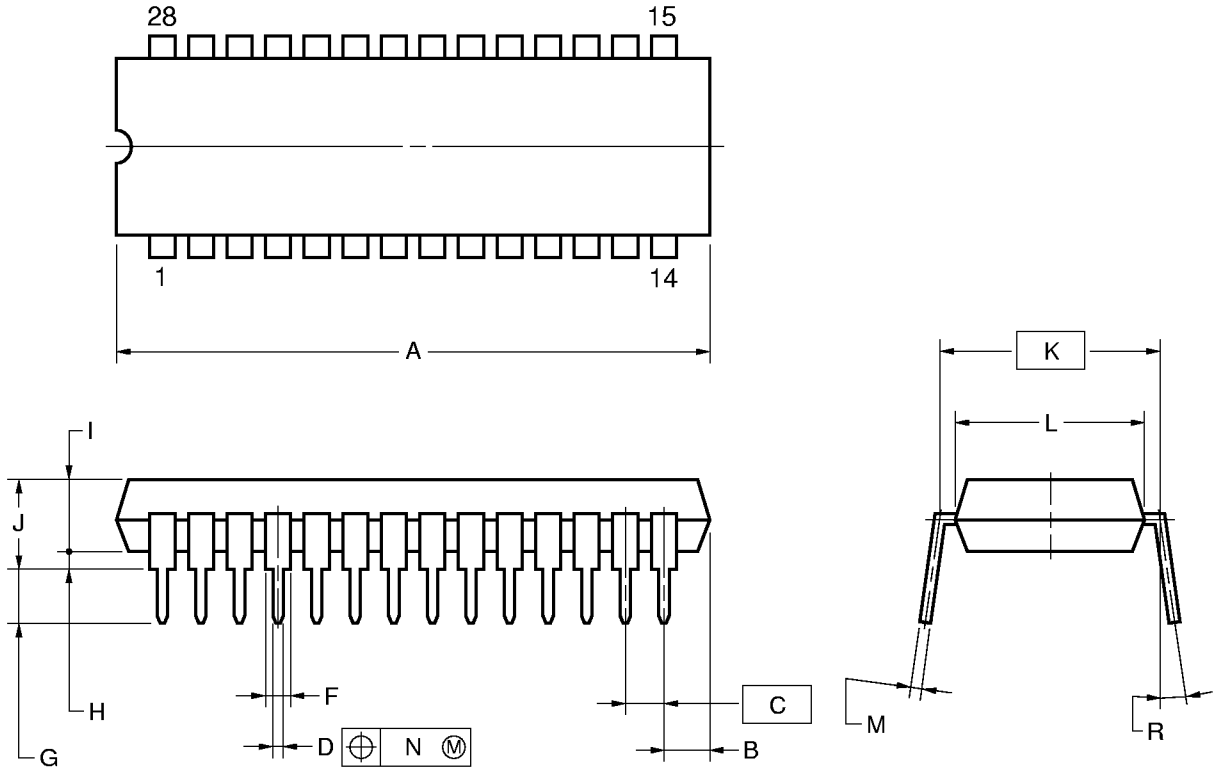

NOTES

- 1) Each lead centerline is located within 0.17 mm (0.007 inch) of its true position (T.P.) at maximum material condition.
- 2) Item "K" to center of leads when formed parallel.

ITEM	MILLIMETERS	INCHES
A	28.46 MAX.	1.121 MAX.
B	2.67 MAX.	0.106 MAX.
C	1.778 (T.P.)	0.070 (T.P.)
D	0.50±0.10	0.020 ^{+0.004} _{-0.005}
F	0.9 MIN.	0.035 MIN.
G	3.2±0.3	0.126±0.012
H	0.51 MIN.	0.020 MIN.
I	4.31 MAX.	0.170 MAX.
J	5.08 MAX.	0.200 MAX.
K	10.16 (T.P.)	0.400 (T.P.)
L	8.6	0.339
M	0.25 ^{+0.10} _{-0.05}	0.010 ^{+0.004} _{-0.003}
N	0.17	0.007
R	0~15°	0~15°

P28C-70-400A-1

30 PIN PLASTIC SHRINK SOP (300 mil)

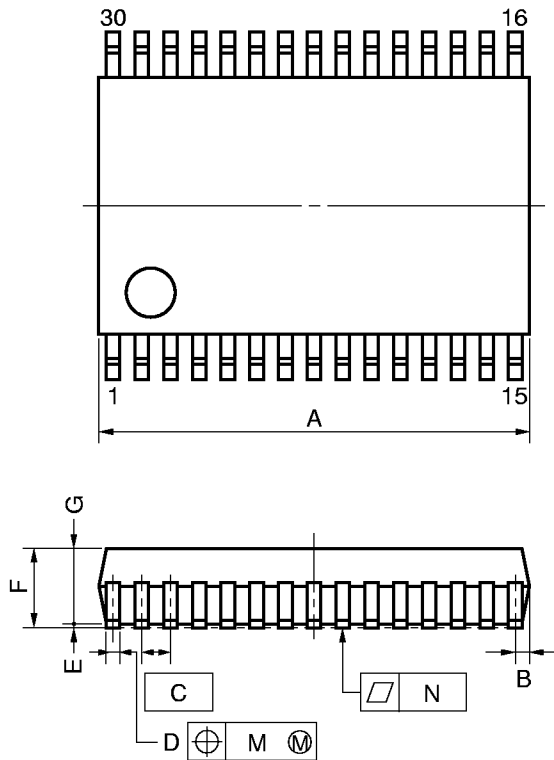

detail of lead end

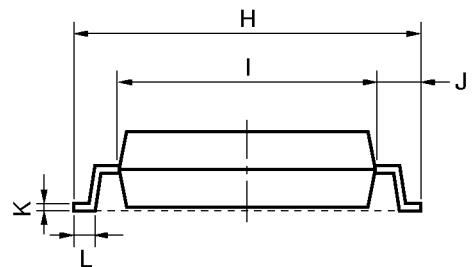
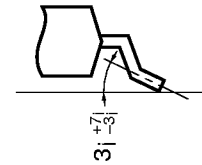

P30GS-65-300B-1

NOTE

Each lead centerline is located within 0.10 mm (0.004 inch) of its true position (T.P.) at maximum material condition.

ITEM	MILLIMETERS	INCHES
A	10.11 MAX.	0.398 MAX.
B	0.51 MAX.	0.020 MAX.
C	0.65 (T.P.)	0.026 (T.P.)
D	0.30 ^{+0.10} _{-0.05}	0.012 ^{+0.004} _{-0.003}
E	0.125±0.075	0.005±0.003
F	2.0 MAX.	0.079 MAX.
G	1.7±0.1	0.067±0.004
H	8.1±0.2	0.319±0.008
I	6.1±0.2	0.240±0.008
J	1.0±0.2	0.039 ^{+0.009} _{-0.008}
K	0.15 ^{+0.10} _{-0.05}	0.006 ^{+0.004} _{-0.002}
L	0.5±0.2	0.020 ^{+0.008} _{-0.009}
M	0.10	0.004
N	0.10	0.004

APPENDIX A DEVELOPMENT TOOLS

The following development tools are available for developing systems using the μPD78F9116.

LANGUAGE PROCESSING SOFTWARE

RA78K0S ^{Notes 1, 2, 3}	Assembler package common to the 78K/0S series
CC78K0S ^{Notes 1, 2, 3}	C compiler package common to the 78K/0S series
DF789134 ^{Notes 1, 2, 3, 5}	Device file for the μPD789114 sub-series
CC78K0S-L ^{Notes 1, 2, 3, 5}	C compiler library source file common to the 78K/0S series

FLASH MEMORY WRITE TOOLS

Flashpro II ^{Note 4}	Dedicated flash writer (formerly, Flashpro)
FA-28CT ^{Note 4}	Flash memory write adapter
Undetermined product name ^{Note 4}	

DEBUGGING TOOLS

ND-K910 ^{Notes 4, 5}	In-circuit emulator for the μPD789114 sub-series The ND-K910 incorporates the NS-78K9 screen debugger.
IF-98D ^{Note 4}	This is an interface board, required when a PC-9800 series (other than a notebook type) are used as the host machine for the ND-K910.
IF-PCD ^{Note 4}	This is an interface board, required when an IBM PC/AT or compatible (other than a notebook type) is used as the host machine for the ND-K910.
IF-CARD ^{Note 4}	This is an interface board, required when a PC-9800 notebook, IBM PC/AT notebook, or compatible is used as the host machine for the ND-K910.
NP-28CT ^{Note 4}	Emulator probe for the 28-pin plastic shrink DIP (CT type)
Undetermined product name ^{Note 4}	Emulator probe for the 30-pin plastic shrink SOP (GS type)
NJ-535 ^{Note 4}	100-/120-V adapter
NJ-550W ^{Note 4}	100- to 240-V adapter
SM78K0S ^{Notes 1, 2}	System simulator common to all 78K/0S series units
DF789134 ^{Notes 1, 2, 5}	Device file for the μPD789134 sub-series

REAL-TIME OS

MX78K0S ^{Notes 1, 2}	OS for the 78K/0S series
-------------------------------	--------------------------

- Notes**
1. Based on the PC-9800 series (MS-DOS™ + Windows™)
 2. Based on the IBM PC/AT™ and compatibles (PC DOS™/IBM DOS™/MS-DOS + Windows)
 3. Based on the HP9000 series 700™ (HP-UX™), SPARCstation™ (SunOS™), and NEWS™ (NEWS-OS™)
 4. Product manufactured by and available from Naito Densai Machida Mfg. Co., Ltd. (044-822-3813).
 5. Under development

Remark The RA78K0S, CC78K0S, and SM78K0S can be used in combination with the DF789134.

APPENDIX B RELATED DOCUMENTS

DOCUMENTS RELATED TO DEVICES

Document name	Document No.	
	Japanese	English
μPD789111, 789112, 789114 Preliminary Product Information	U13013J	To be created
μPD78F9116 Preliminary Product Information	U13037J	This manual
μPD789134 Sub-Series User's Manual	To be created	To be created
78K/0S Series User's Manual, Instruction	U11047J	U11047E
78K/0S Series Instruction Summary Sheet	To be created	-
78K/0S Series Instruction Set	To be created	-

DOCUMENTS RELATED TO DEVELOPMENT TOOLS (USER'S MANUAL)

Document name		Document No.	
		Japanese	English
RA78K0S Assembler Package	Operation	U11622J	U11622E
	Assembly Language	U11599J	U11599E
	Structured Assembly Language	U11623J	U11623E
CC78K/0S C Compiler	Operation	U11816J	U11816E
	Language	U11817J	U11817E
SM78K0S System Simulator Windows Base	Reference	U11489J	U11489E
SM78K Series System Simulator	External Parts User Open Interface Specifications	U10092J	U10092E

DOCUMENTS RELATED TO SOFTWARE TO BE INCORPORATED INTO THE PRODUCT (USER'S MANUAL)

Document name		Document No.	
		Japanese	English
OS for 78K/0S Series MX78K0S	Fundamental	U12938J	To be created

Caution The above documents may be revised without notice. Use the latest versions when you design application systems.

OTHER DOCUMENTS

Document name	Document No.	
	Japanese	English
IC PACKAGE MANUAL	C10943X	
SMD Surface Mount Technology Manual	C10535J	C10535E
Quality Grades on NEC Semiconductor Device	C11531J	C11531E
NEC Semiconductor Device Reliability/Quality Control System	C10983J	C10983E
Guide to Prevent Damage for Semiconductor Devices by Electrostatic Discharge (ESD)	C11892J	C11892E
Semiconductor Device Quality Control/Reliability Handbook	C12769J	-
Guide for Products Related to Microcontroller: Other Companies	U11416J	-

Caution The above documents may be revised without notice. Use the latest versions when you design application systems.

NOTES FOR CMOS DEVICES**① PRECAUTION AGAINST ESD FOR SEMICONDUCTORS**

Note: Strong electric field, when exposed to a MOS device, can cause destruction of the gate oxide and ultimately degrade the device operation. Steps must be taken to stop generation of static electricity as much as possible, and quickly dissipate it once, when it has occurred. Environmental control must be adequate. When it is dry, humidifier should be used. It is recommended to avoid using insulators that easily build static electricity. Semiconductor devices must be stored and transported in an anti-static container, static shielding bag or conductive material. All test and measurement tools including work bench and floor should be grounded. The operator should be grounded using wrist strap. Semiconductor devices must not be touched with bare hands. Similar precautions need to be taken for PW boards with semiconductor devices on it.

② HANDLING OF UNUSED INPUT PINS FOR CMOS

Note: No connection for CMOS device inputs can be cause of malfunction. If no connection is provided to the input pins, it is possible that an internal input level may be generated due to noise, etc., hence causing malfunction. CMOS devices behave differently than Bipolar or NMOS devices. Input levels of CMOS devices must be fixed high or low by using a pull-up or pull-down circuitry. Each unused pin should be connected to V_{DD} or GND with a resistor, if it is considered to have a possibility of being an output pin. All handling related to the unused pins must be judged device by device and related specifications governing the devices.

③ STATUS BEFORE INITIALIZATION OF MOS DEVICES

Note: Power-on does not necessarily define initial status of MOS device. Production process of MOS does not define the initial operation status of the device. Immediately after the power source is turned ON, the devices with reset function have not yet been initialized. Hence, power-on does not guarantee out-pin levels, I/O settings or contents of registers. Device is not initialized until the reset signal is received. Reset operation must be executed immediately after power-on for devices having reset function.