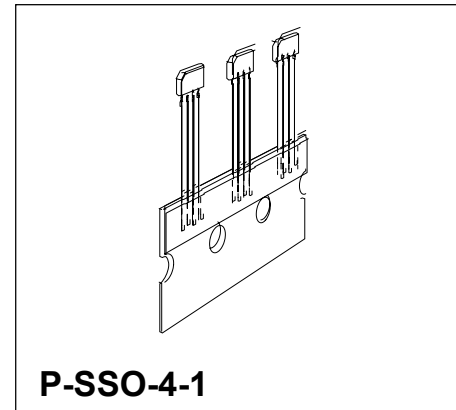


**Bipolar IC**

**Features**

- **Advanced performance**
- **High sensitivity**
- **Symmetrical thresholds**
- **High piezo resistivity**
- **Reduced power consumption**
- **South and north pole pre-induction possible**
- AC coupled
- Digital output signal
- Two-wire and three-wire configuration possible
- Large temperature range
- Large airgap
- Low cut-off frequency
- Protection against overvoltage
- Protection against reversed polarity
- Output protection against electrical disturbances



<b>Type</b>	<b>Marking</b>	<b>Ordering Code</b>	<b>Package</b>
TLE4921-5U	21C5U	Q62705-K664	PSSO4-1

The differential Hall Effect sensor TLE 4921-5U provides a high sensitivity and a superior stability over temperature and symmetrical thresholds in order to achieve a stable duty cycle. TLE 4921-5U is particularly suitable for rotational speed detection and timing applications of ferromagnetic toothed wheels such as anti-lock braking systems, transmissions, crankshafts, etc. The integrated circuit (based on Hall effect) provides a digital signal output with frequency proportional to the speed of rotation. Unlike other rotational sensors differential Hall ICs are not influenced by radial vibration within the effective airgap of the sensor and require no external signal processing.

### Pin Configuration

(view on branded side of component)

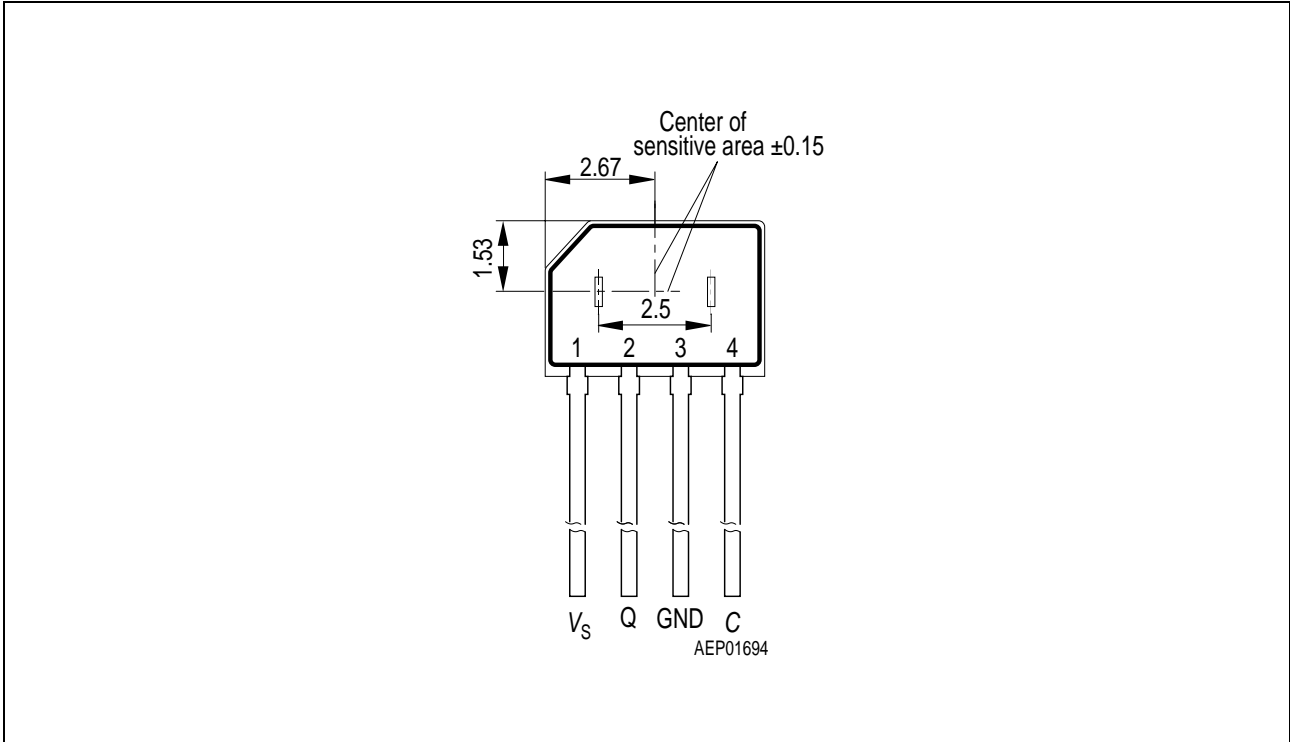
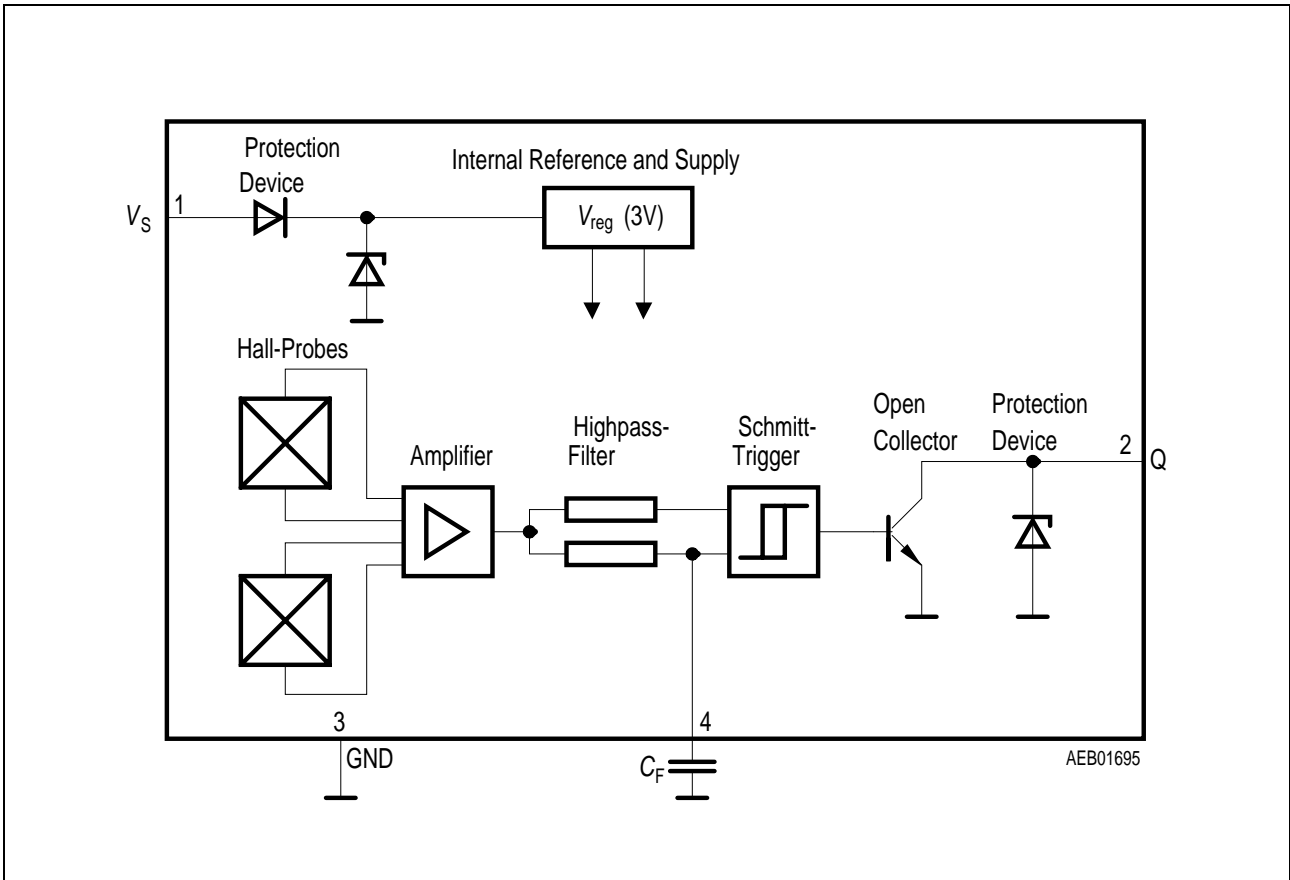


Figure 1

### Pin Definitions and Functions

Pin No.	Symbol	Function
1	$V_S$	Supply Voltage
2	Q	Output
3	GND	Ground
4	C	Capacitor



**Figure 2** Block Diagram

## Functional Description

The Differential Hall Sensor IC detects the motion and position of ferromagnetic and permanent magnet structures by measuring the differential flux density of the magnetic field. To detect ferromagnetic objects the magnetic field must be provided by a back biasing permanent magnet (**south or north** pole of the magnet attached to the rear unmarked side of the IC package).

Using an external capacitor the generated Hall voltage signal is slowly adjusted via an active high pass filter with a low cut-off frequency. This causes the output to switch into a biased mode after a time constant is elapsed. The time constant is determined by the external capacitor. Filtering avoids ageing and temperature influence from Schmitt-trigger input and eliminates device and magnetic offset.

The TLE 4921-5U can be exploited to detect toothed wheel rotation in a rough environment. Jolts against the toothed wheel and ripple have no influence on the output signal.

Furthermore, the TLE 4921-5U can be operated in a two-wire as well as in a three-wire-configuration.

The output is logic compatible by high/low levels regarding on and off.

## Circuit Description (see Figure 2)

The TLE 4921-5U is comprised of a supply voltage reference, a pair of Hall probes spaced at 2.5 mm, differential amplifier, filter for offset compensation, Schmitt trigger, and an open collector output.

**The TLE 4921-5U was designed to have a wide range of application parameter variations. Differential fields up to  $\pm 80$  mT can be detected without influence to the switching performance. The pre-induction field can either come from a magnetic south or north pole, whereby the field strength up to 500 mT or more will not influence the switching points. The improved temperature compensation enables a superior sensitivity and accuracy over the temperature range. Finally the optimised piezo compensation and the integrated dynamic offset compensation enable easy manufacturing and elimination of magnet offsets.**

Protection is provided at the input/supply (pin 1) for overvoltage and reverse polarity and against over-stress such as load dump, etc., in accordance with ISO-TR 7637 and DIN 40839. The output (pin 2) is protected against voltage peaks and electrical disturbances.

**Absolute Maximum Ratings**
 $T_j = -40$  to  $150$  °C

Parameter	Symbol	Limit Values		Unit	Remarks
		min.	max.		
Supply voltage	$V_S$	$-35$ <sup>1)</sup>	30	V	–
Output voltage	$V_Q$	$-0.7$	30	V	–
Output current	$I_Q$	–	50	mA	–
Output reverse current	$-I_Q$	–	50	mA	–
Capacitor voltage	$V_C$	$-0.3$	3	V	–
Junction temperature	$T_j$	–	150	°C	5000 h
Junction temperature	$T_j$	–	160	°C	2500 h
Junction temperature	$T_j$	–	170	°C	1000 h
Junction temperature	$T_j$	–	210	°C	40 h
Storage temperature	$T_S$	$-40$	150	°C	–
Thermal resistance P-SSO-4-1	$R_{th JA}$	–	190	K/W	–
Current through input- protection device	$I_{SZ}$	–	200	mA	$t < 2$ ms; $v = 0.1$
Current through output- protection device	$I_{QZ}$	–	200	mA	$t < 2$ ms; $v = 0.1$

**Electro Magnetic Compatibility**

ref. DIN 40839 part 1; test circuit 1

Testpulse 1	$V_{LD}$	Level IV	-100 V	C	
Testpulse 2	$V_{LD}$	Level IV	100 V	B	
Testpulse 3a	$V_{LD}$	Level IV	-150V	C	
Testpulse 3b	$V_{LD}$	Level IV	100V	C	
Testpulse 4	$V_{LD}$	Level IV	-7V	C	
Testpulse 5	$V_{LD}$	Level IV	86,5V	C	

<sup>1)</sup> Reverse current < 10mA

*Note: Stresses above those listed here may cause permanent damage to the device. Exposure to absolute maximum rating conditions for extended periods may affect device reliability.*

## ESD Protection

Human Body Model (HBM) tests according to:

Parameter	Symbol	max.	Unit	Remarks
ESD – protection	$V_{ESD}$	$\pm 2$	kV	According to standard EIA/JESD22-A114-B HBM

## Operating Range

Parameter	Symbol	Limit Values		Unit	Remarks
		min.	max.		
Supply voltage	$V_S$	4.5	24	V	–
Junction temperature	$T_j$	– 40	170	°C	–
Pre-induction	$B_0$	– 500	500	mT	at Hall probe; independent of magnet orientation
Differential induction	$\Delta B$	– 80	80	mT	–

*Note: In the operating range the functions given in the circuit description are fulfilled.*

## AC/DC Characteristics

Parameter	Symbol	Limit Values			Unit	Test Conditions	Test Circuit
		min.	typ.	max.			
<b>Supply current</b> <sup>(1)</sup>	$I_S$	3.8	5.3	8.0	<b>mA</b>	$V_Q = \text{high}$ $I_Q = 0 \text{ mA}$	1
		4.3	5.9	8.8	<b>mA</b>	$V_Q = \text{low}$ $I_Q = 40 \text{ mA}$	1
Output saturation voltage	$V_{Qsat}$	–	0.25	0.6	V	$I_Q = 40 \text{ mA}$	1
Output leakage current	$I_{QL}$	–	–	50	$\mu\text{A}$	$V_Q \leq 24 \text{ V}$	1
<b>Centre of switching points: <math>(\Delta B_{OP} + \Delta B_{RP})/2</math></b>	$\Delta B_m$	<b>– 1</b>	<b>0</b>	<b>1</b>	<b>mT</b>	<b><math>- 20 \text{ mT} &lt; \Delta B &lt; 20 \text{ mT}</math></b> <sup>2)3)</sup> <b><math>f = 200 \text{ Hz}</math></b>	2
Operate point	$\Delta B_{OP}$	–	–	0	mT	$f = 200 \text{ Hz}$ , $\Delta B = 20 \text{ mT}$	2

Release point	$\Delta B_{RP}$	0	–	–	mT	$f = 200 \text{ Hz}$ , $\Delta B = 20 \text{ mT}$	2
Hysteresis	$\Delta B_{Hy}$	0.5	1.5	2.5	mT	$f = 200 \text{ Hz}$ , $\Delta B = 20 \text{ mT}$	2
Overvoltage protection at supply voltage at output	$V_{SZ}$	27	–	35	V	$I_S = 16 \text{ mA}$	1
	$V_{QZ}$	27	–	35	V	$I_Q = 16 \text{ mA}$	1
Output rise time	$t_r$	–	–	0.5	$\mu\text{s}$	$I_Q = 40 \text{ mA}$ $C_L = 10 \text{ pF}$	1

**AC/DC Characteristics (cont'd)**

Parameter	Symbol	Limit Values			Unit	Test Conditions	Test Circuit
		min.	typ.	max.			
Output fall time	$t_f$	–	–	0.5	$\mu\text{s}$	$I_Q = 40 \text{ mA}$ $C_L = 10 \text{ pF}$	1
Delay time	$t_{dop}$	–	–	25	$\mu\text{s}$	$f = 10 \text{ kHz}$ $\Delta B = 5 \text{ mT}$	2
	$t_{drp}$	–	–	10	$\mu\text{s}$		
	$t_{dop} - t_{drp}$	–	0	15	$\mu\text{s}$		
Filter input resistance	$R_C$	35	43	52	k $\Omega$	$25 \text{ }^\circ\text{C} \pm 2$ $^\circ\text{C}$	1
Filter sensitivity to $\Delta B$	$S_C$	–	– 5	–	mV/ mT	–	1
Filter bias voltage	$V_C$	<u>1.6</u>	<u>2</u>	<u>2.4</u>	V	$\Delta B = 0$	1
Frequency	$f$	<sup>4)</sup>	–	20000	Hz	$\Delta B = 5 \text{ mT}$	2
Resistivity against mechanical stress (piezo)	$\Delta B_m$	– 0.1	–	0.1	mT	F = 2 N	2
	$\Delta B_{Hy}$	– 0.1	–	0.1	mT		

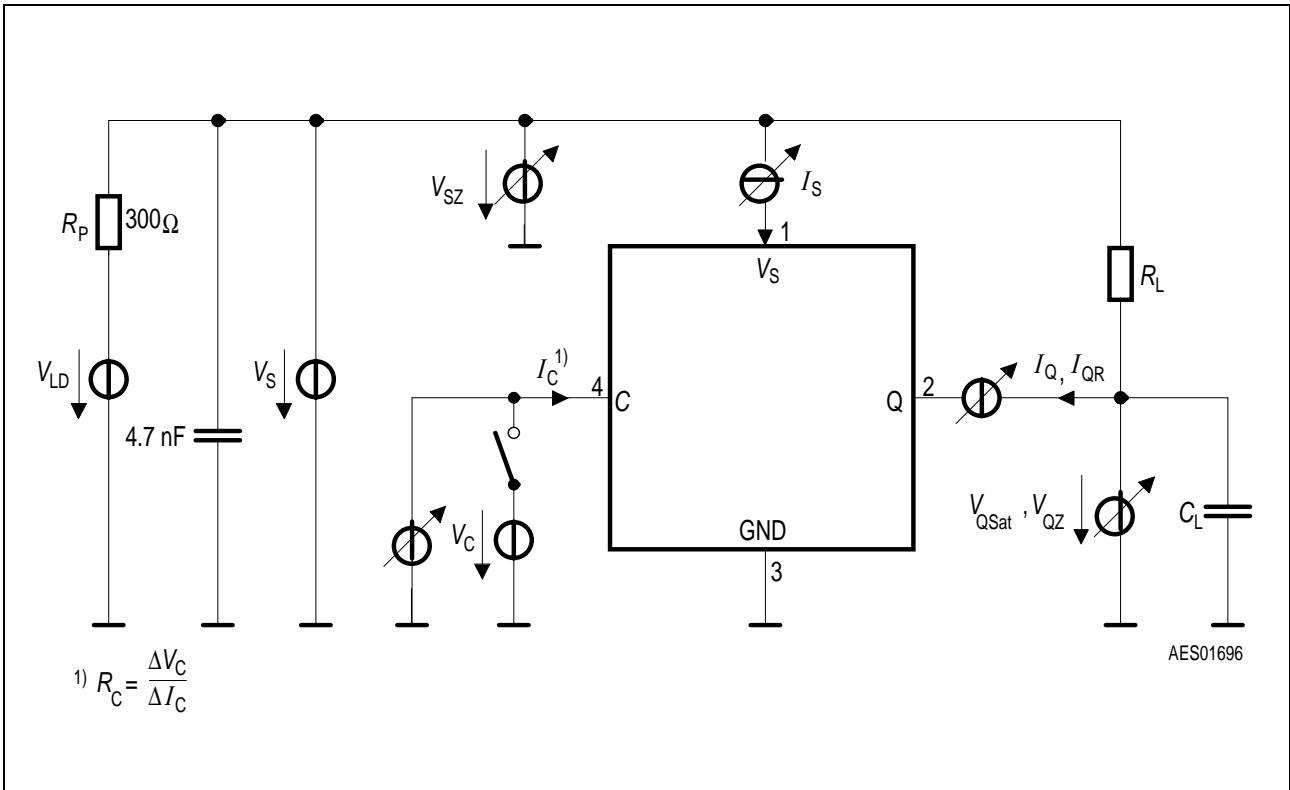
<sup>2)</sup> The Current consumption characteristic will be different and the specified values can slightly change

<sup>3)</sup> Leakage currents at pin 4 should be avoided. The bias shift of  $B_m$  caused by a leakage current  $I_L$  can be calculated by:  $\Delta B_m = (I_L \times R_C(T)) / S_C(T)$

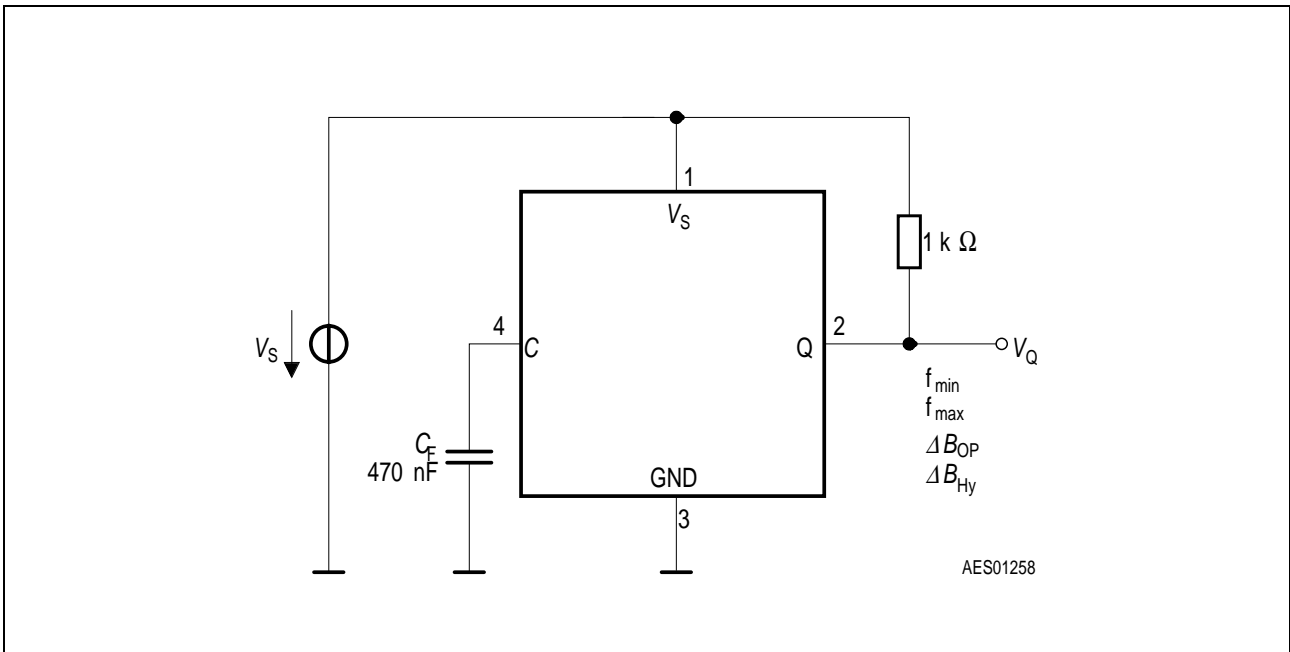
<sup>4)</sup> For higher  $\Delta B$  the values may exceed the limits like following  $|\Delta B_m| < |0.05 \times \Delta B|$

<sup>5)</sup> Depends on filter capacitor  $C_F$ . The cut-off frequency is given by  $f = 1 / (2\pi \times R_C \times C_F)$ .  
The switching points are guaranteed over the whole frequency range, but amplitude modification and phase shift due to the 1<sup>st</sup> order high-pass filter have to be taken into account.

*Note: The listed characteristics are ensured over the operating range of the integrated circuit. Typical characteristics specify mean values expected over the production spread. If not otherwise specified, typical characteristics apply at  $T_j = 25 \text{ }^\circ\text{C}$  and the given supply voltage.*



**Figure 3 Test Circuit 1**



**Figure 4 Test Circuit 2**



### Application Configurations

Two possible applications are shown in **Figure 7** and **Figure 8** (Toothed and Magnet Wheel).

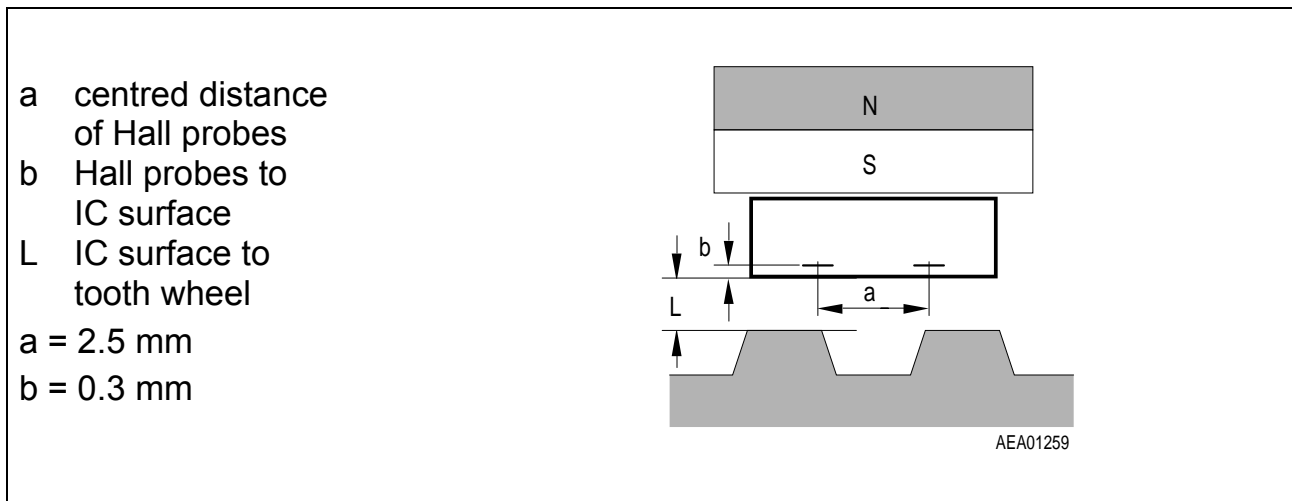
The difference between two-wire and three-wire application is shown in **Figure 9**.

### Gear Tooth Sensing

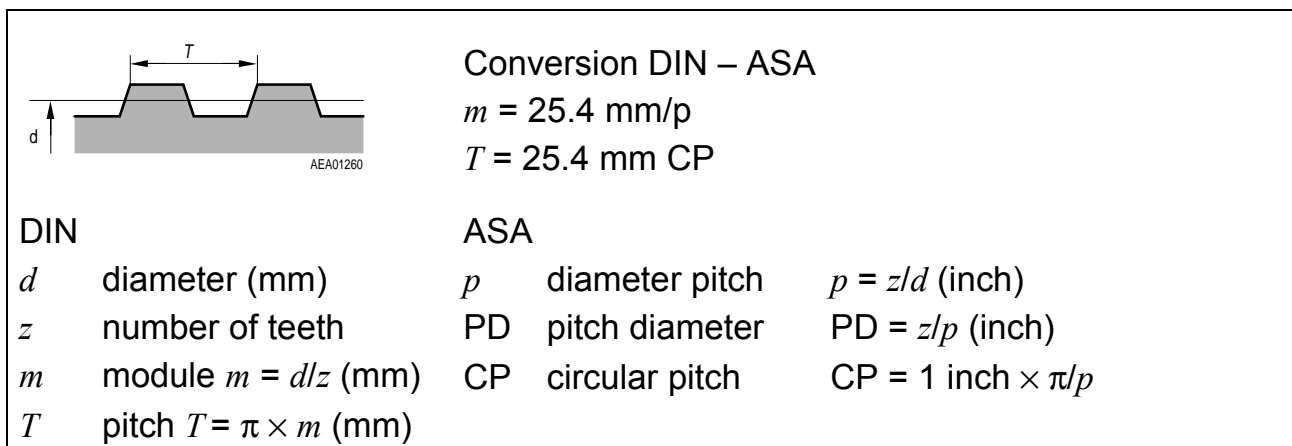
In the case of ferromagnetic toothed wheel application the IC has to be biased by the south or north pole of a permanent magnet (e.g. SmCO<sub>5</sub> (Vacuumschmelze VX145)) with the dimensions 8 mm × 5 mm × 3 mm) which should cover both Hall probes.

The maximum air gap depends on

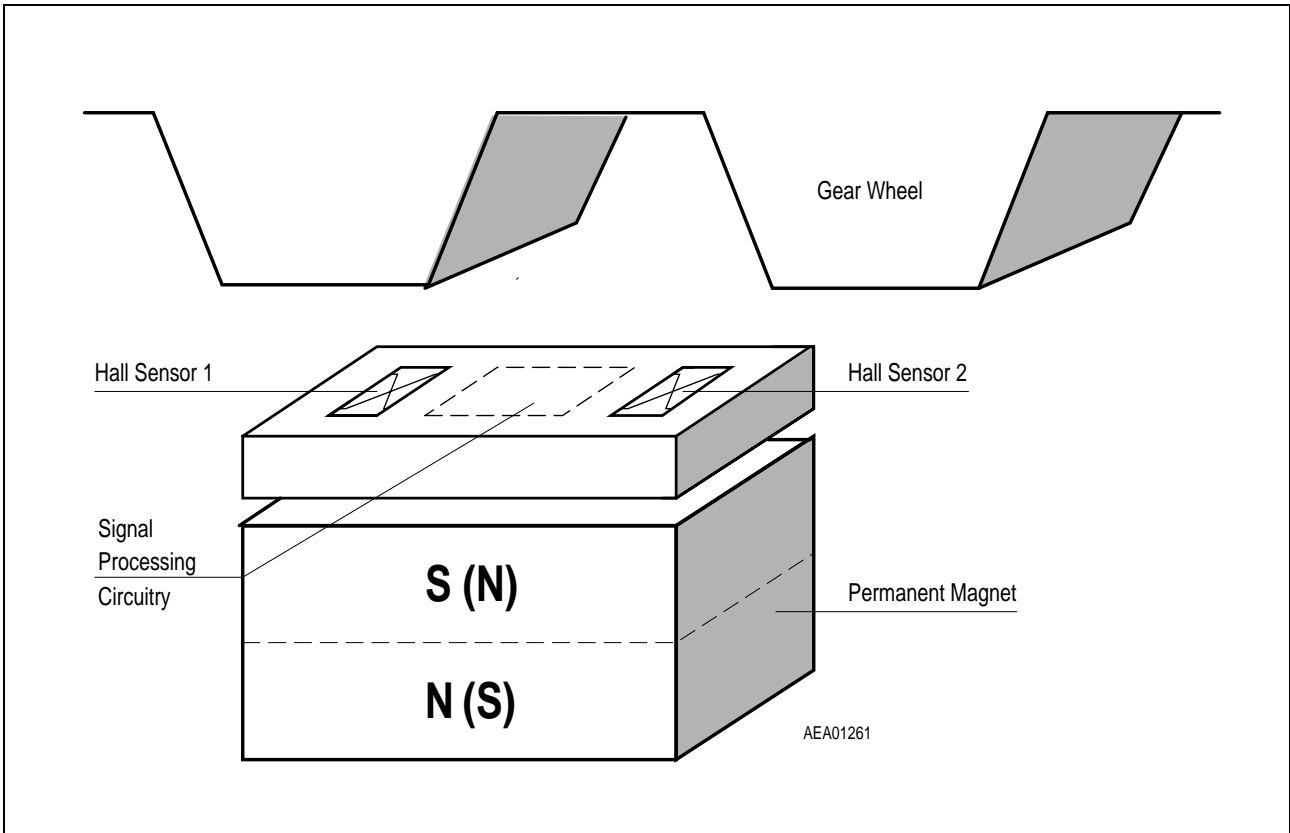
- the magnetic field strength (magnet used; pre-induction) and
- the toothed wheel that is used (dimensions, material, etc.; resulting differential field)



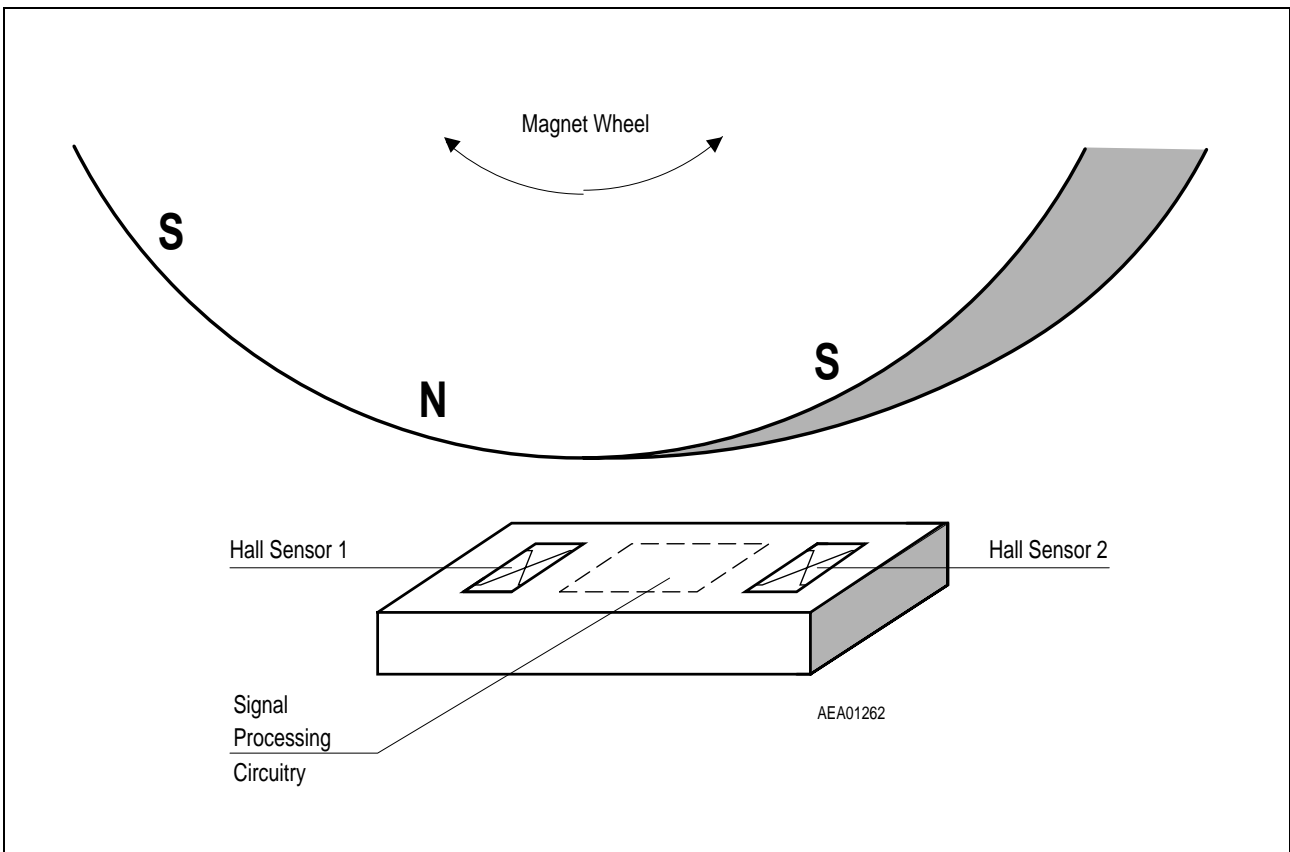
**Figure 5 Sensor Spacing**



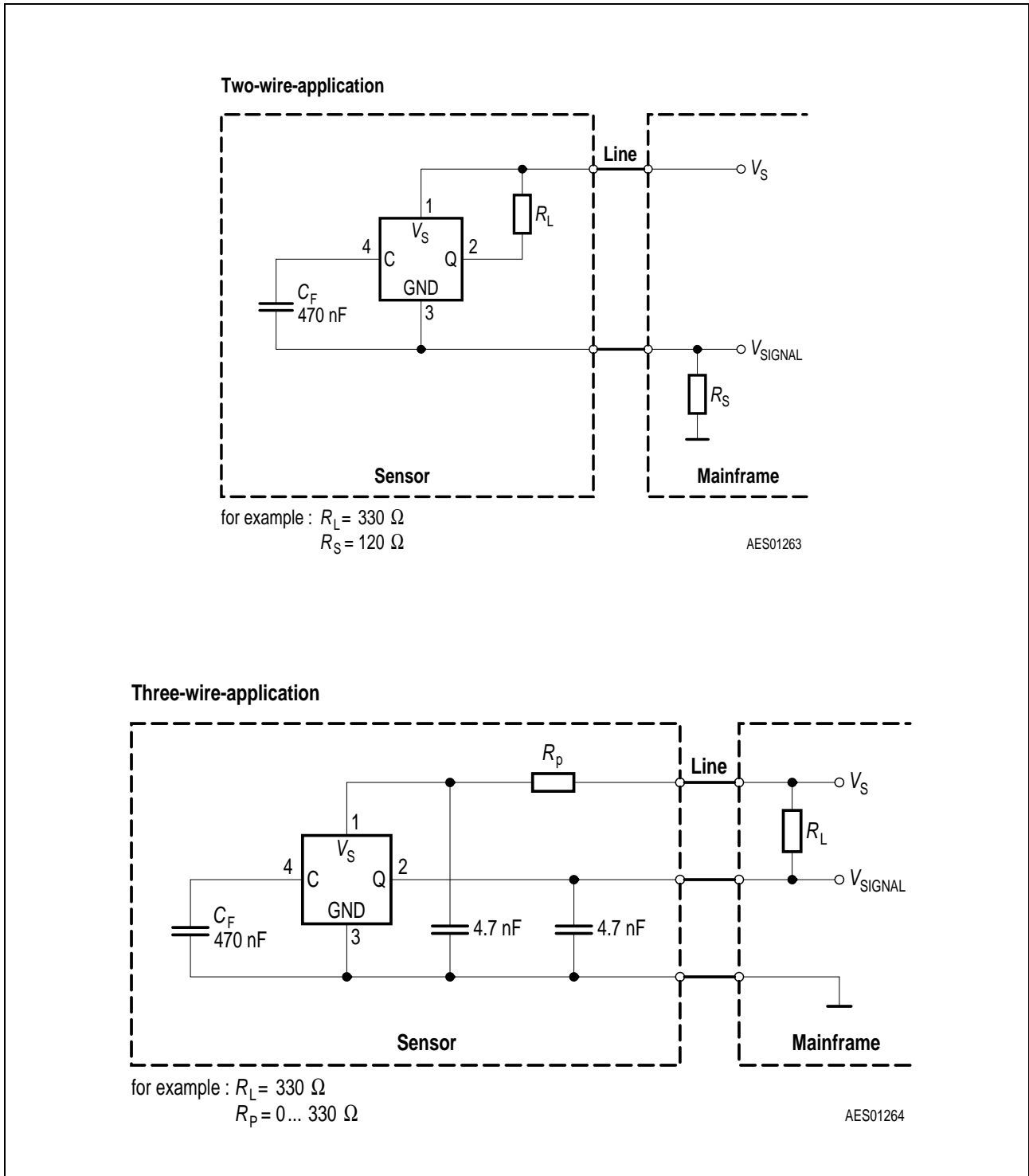
**Figure 6 Toothed Wheel Dimensions**



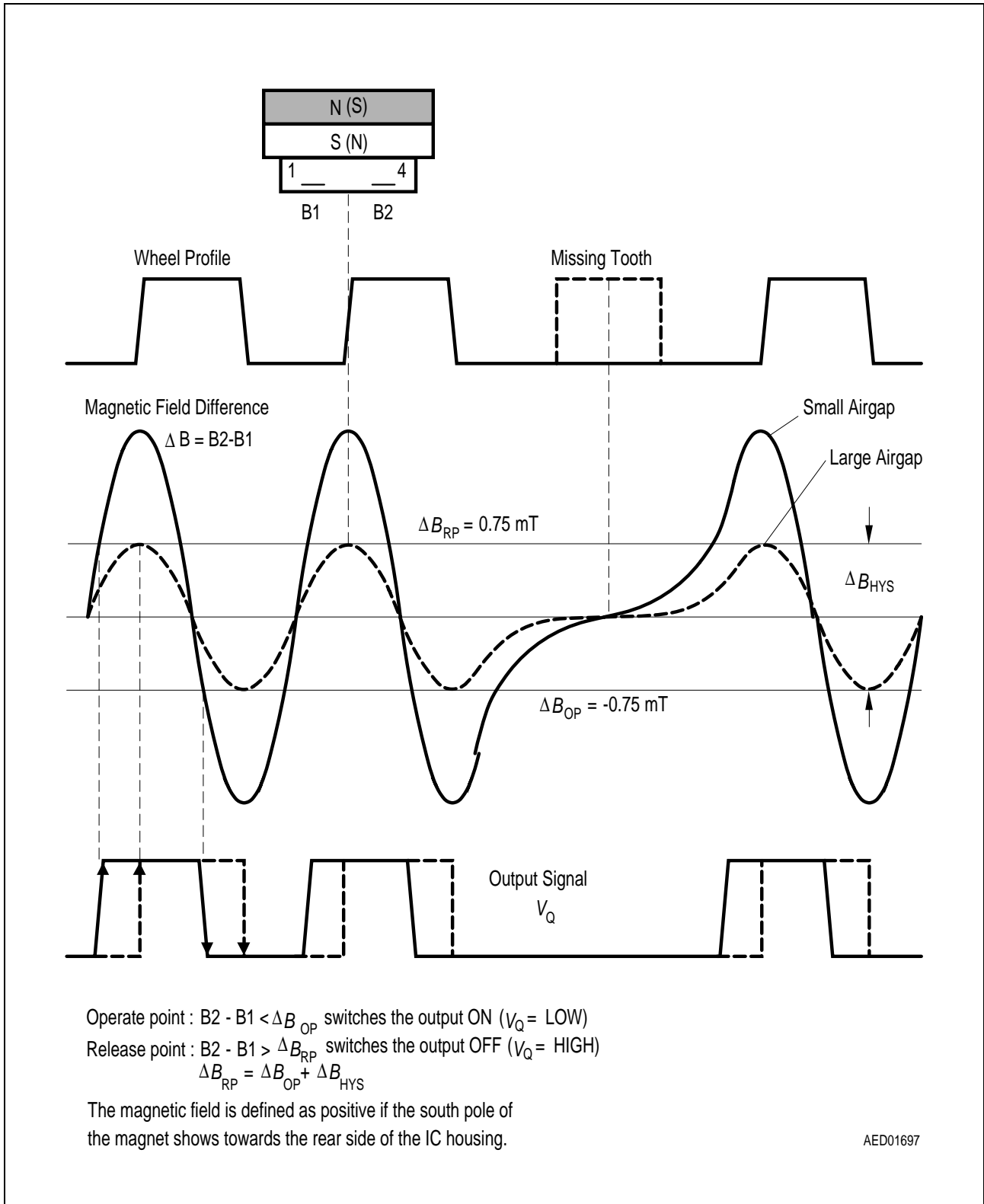
**Figure 7** TLE 4921-5U, with Ferromagnetic Toothed Wheel



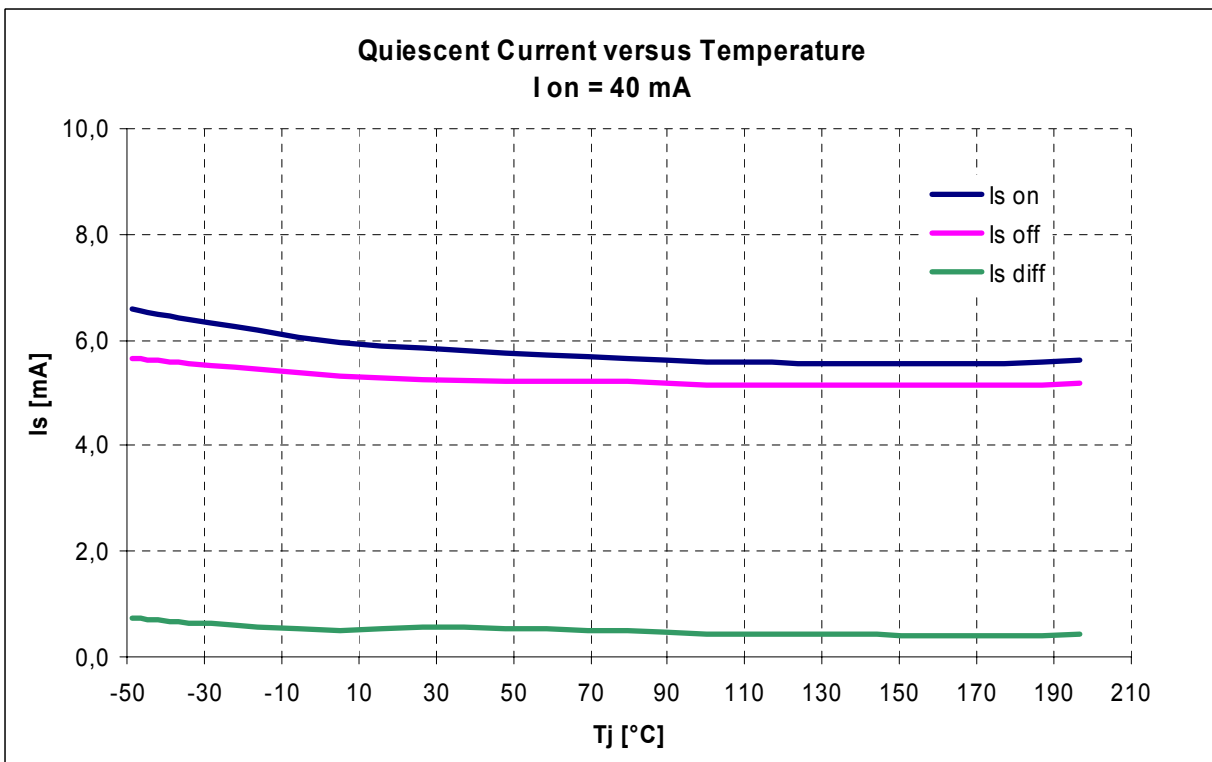
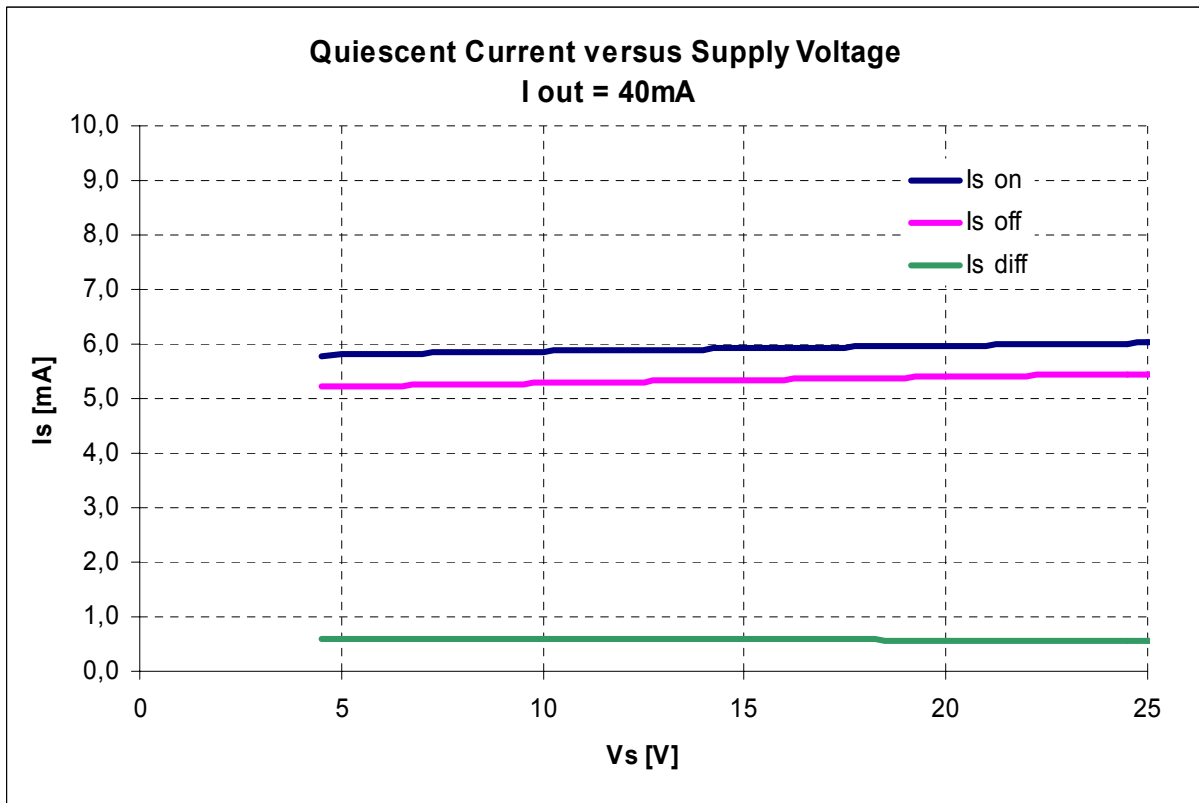
**Figure 8** TLE 4921-5U, with Magnet Wheel

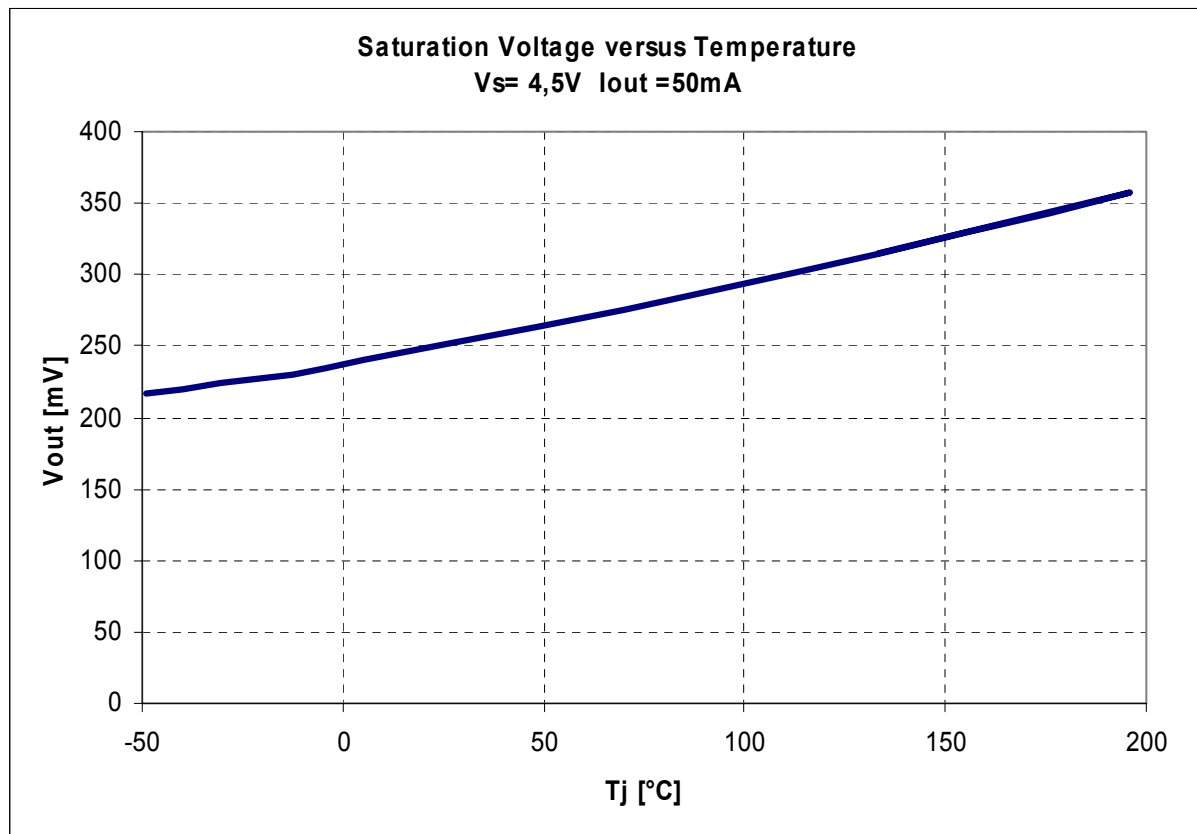
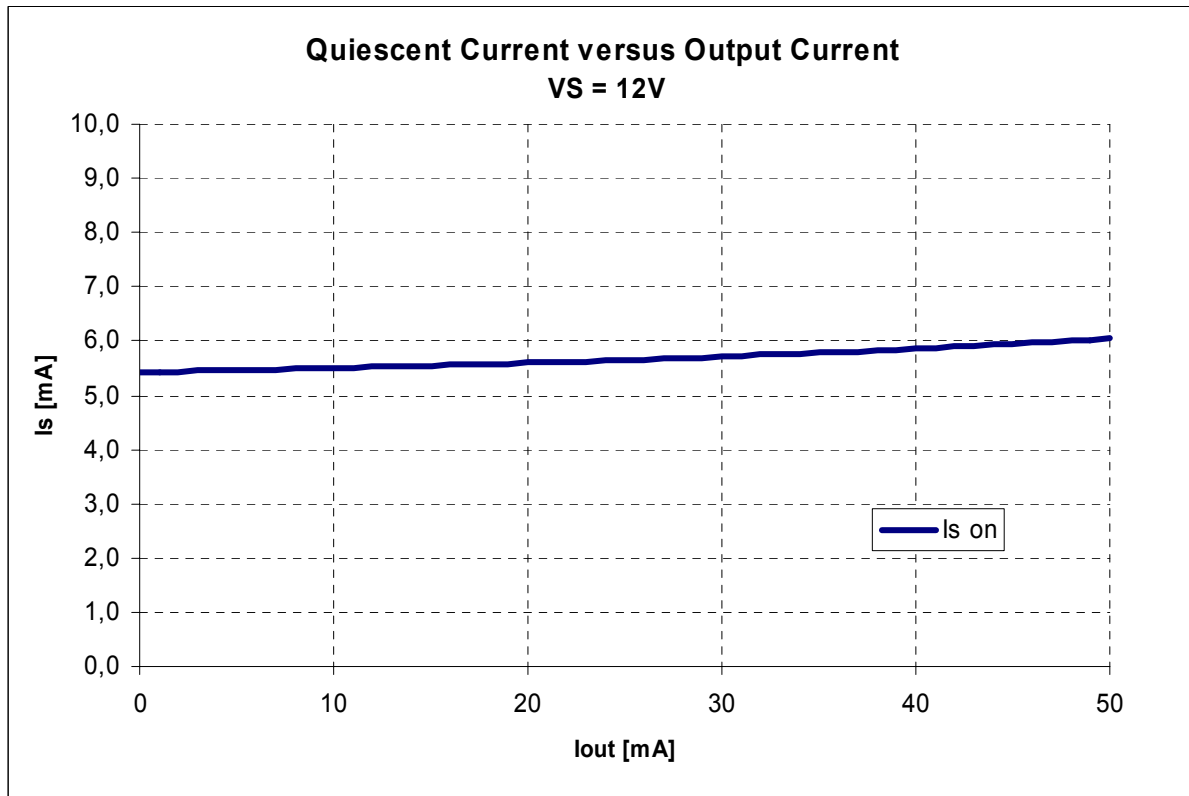


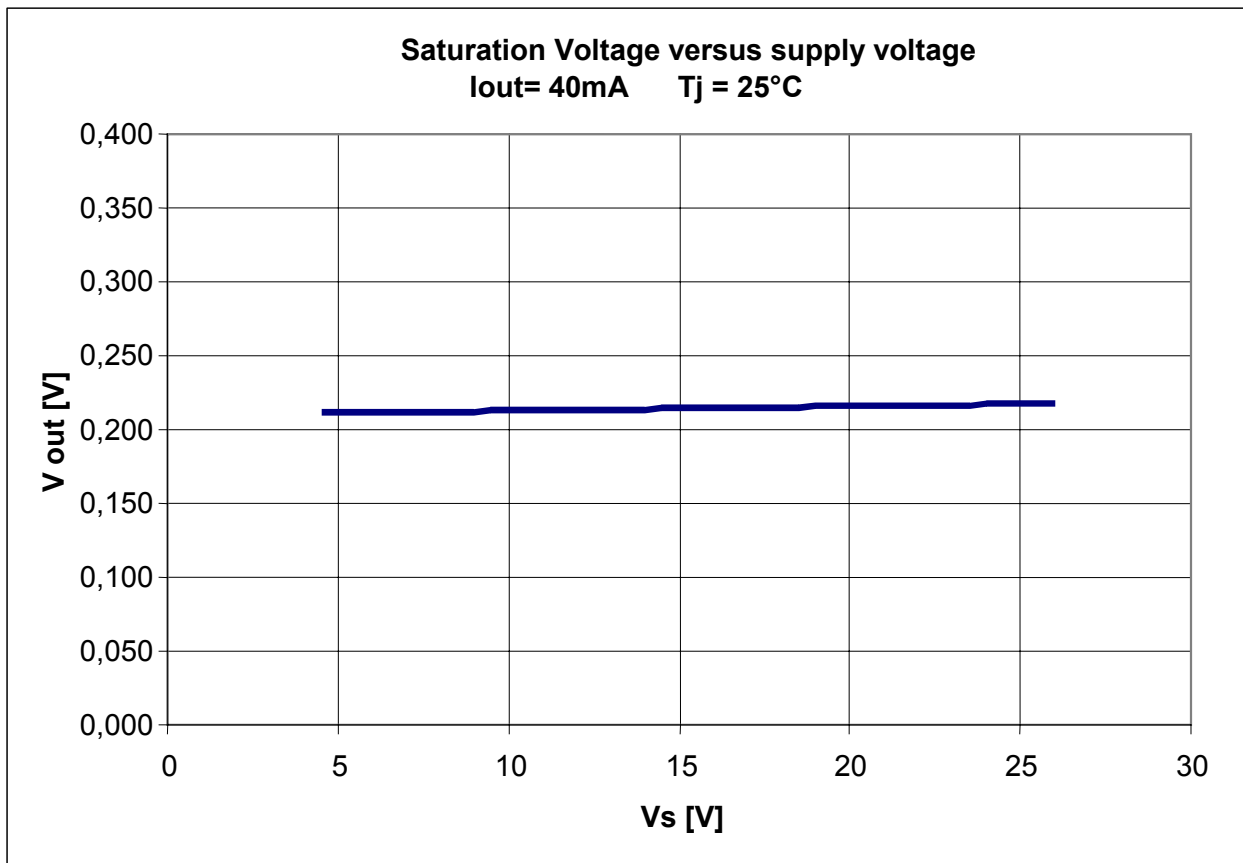
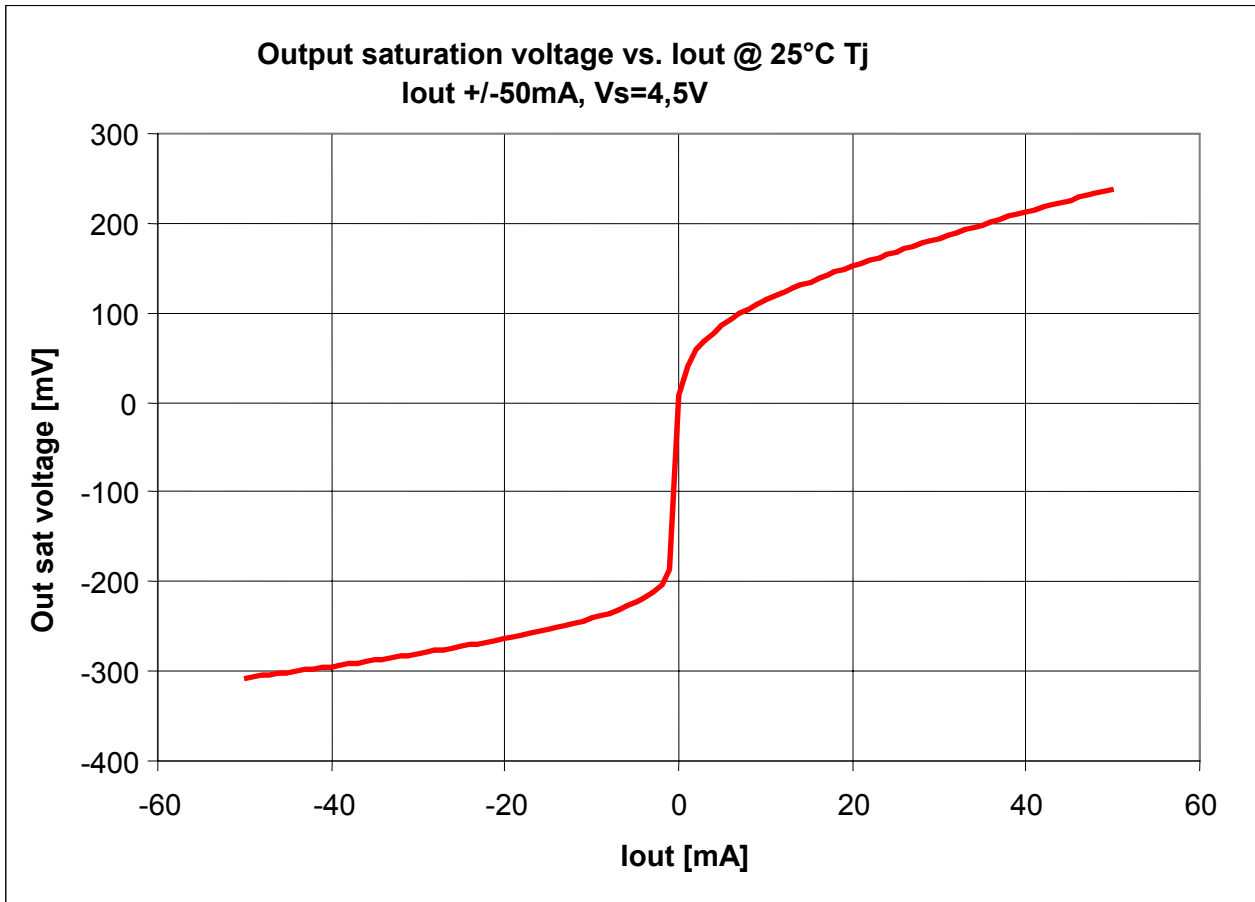
**Figure 9 Application Circuits**

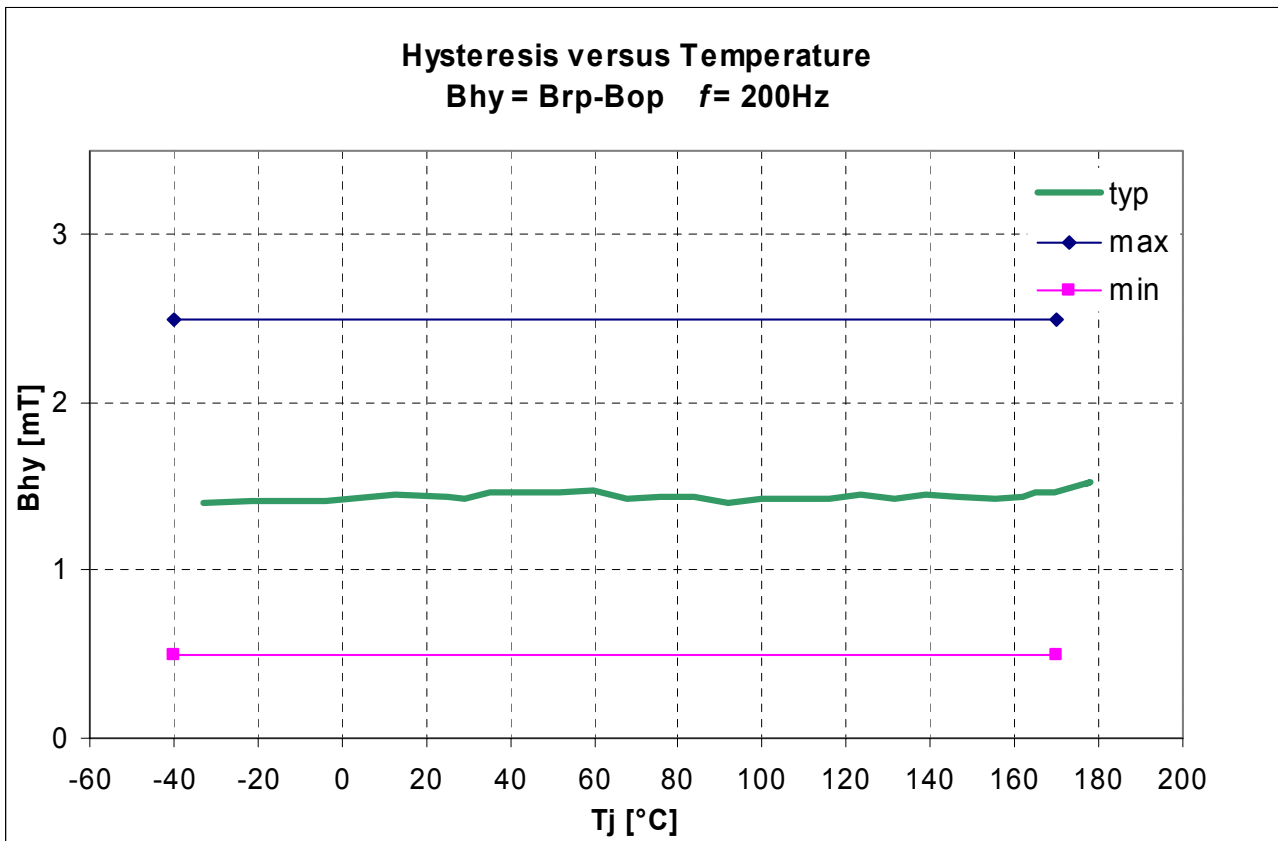
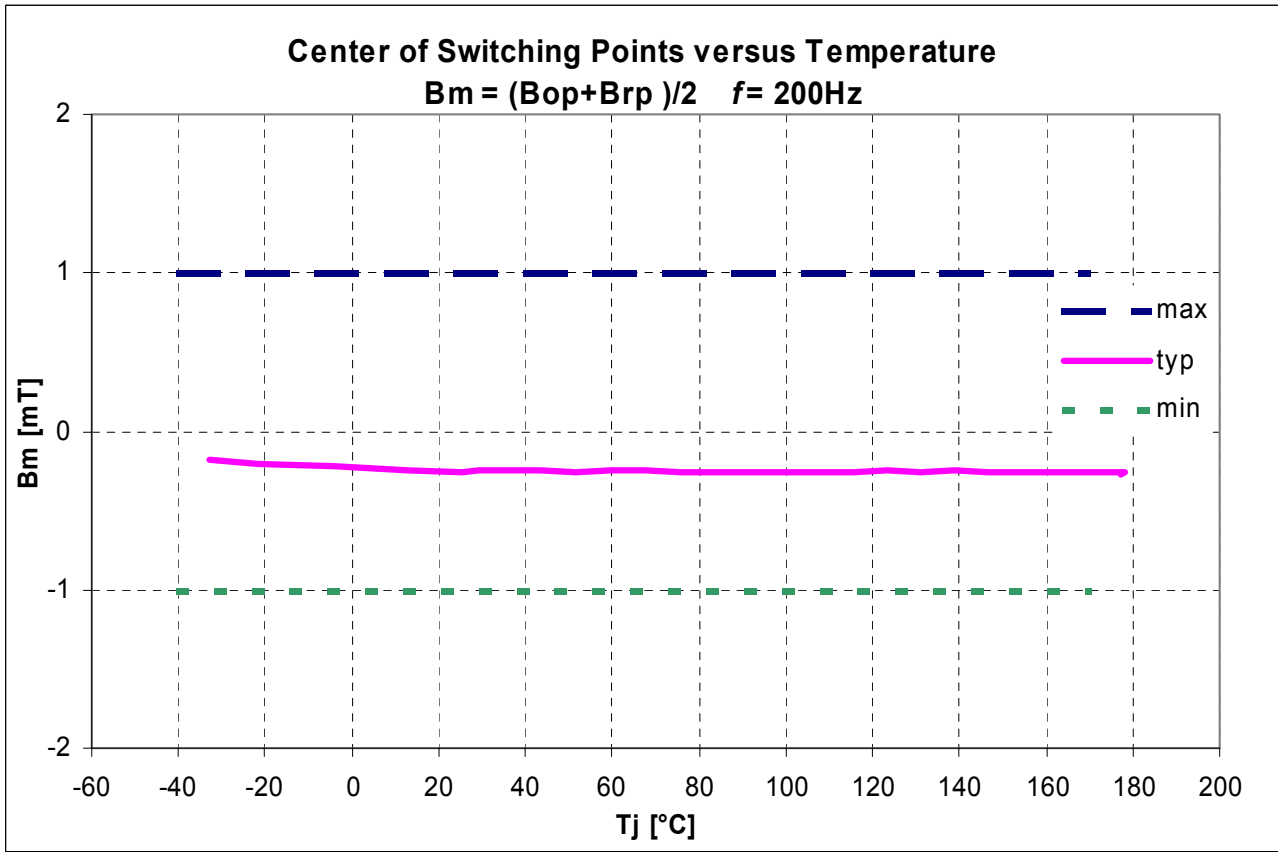


**Figure 10 System Operation**

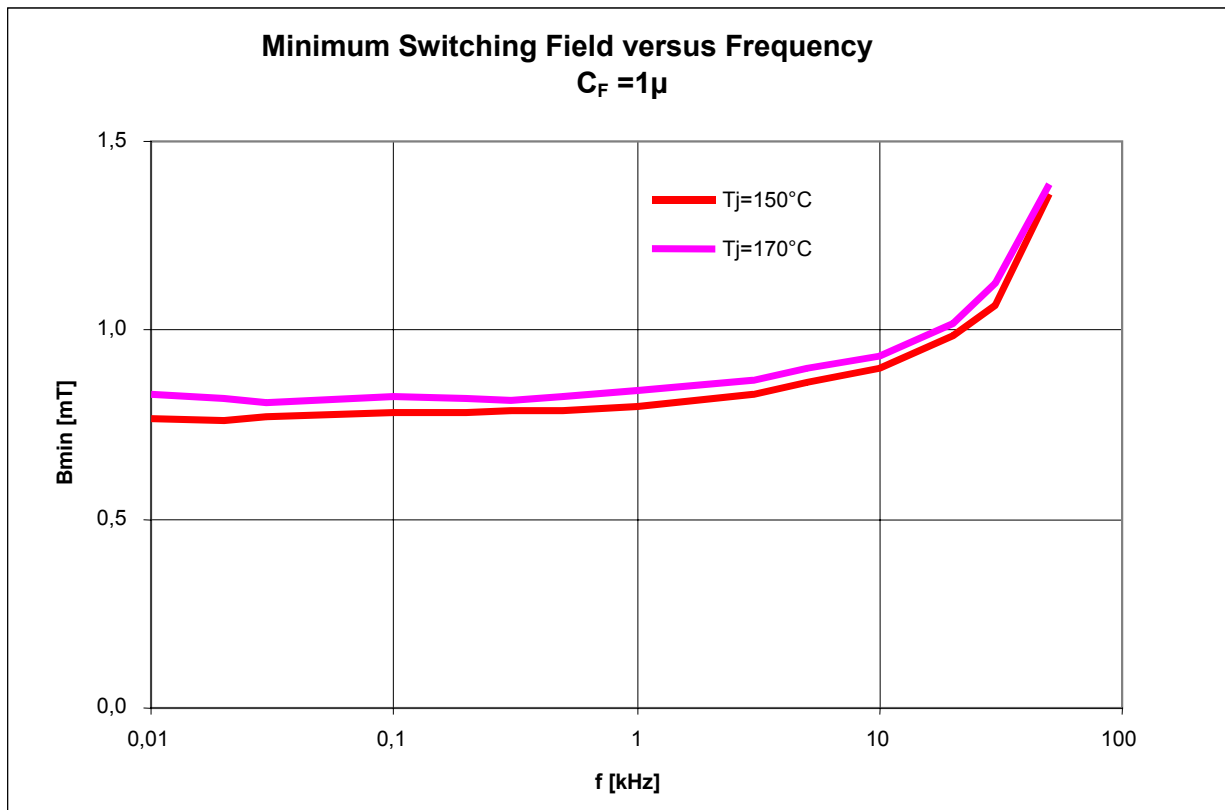
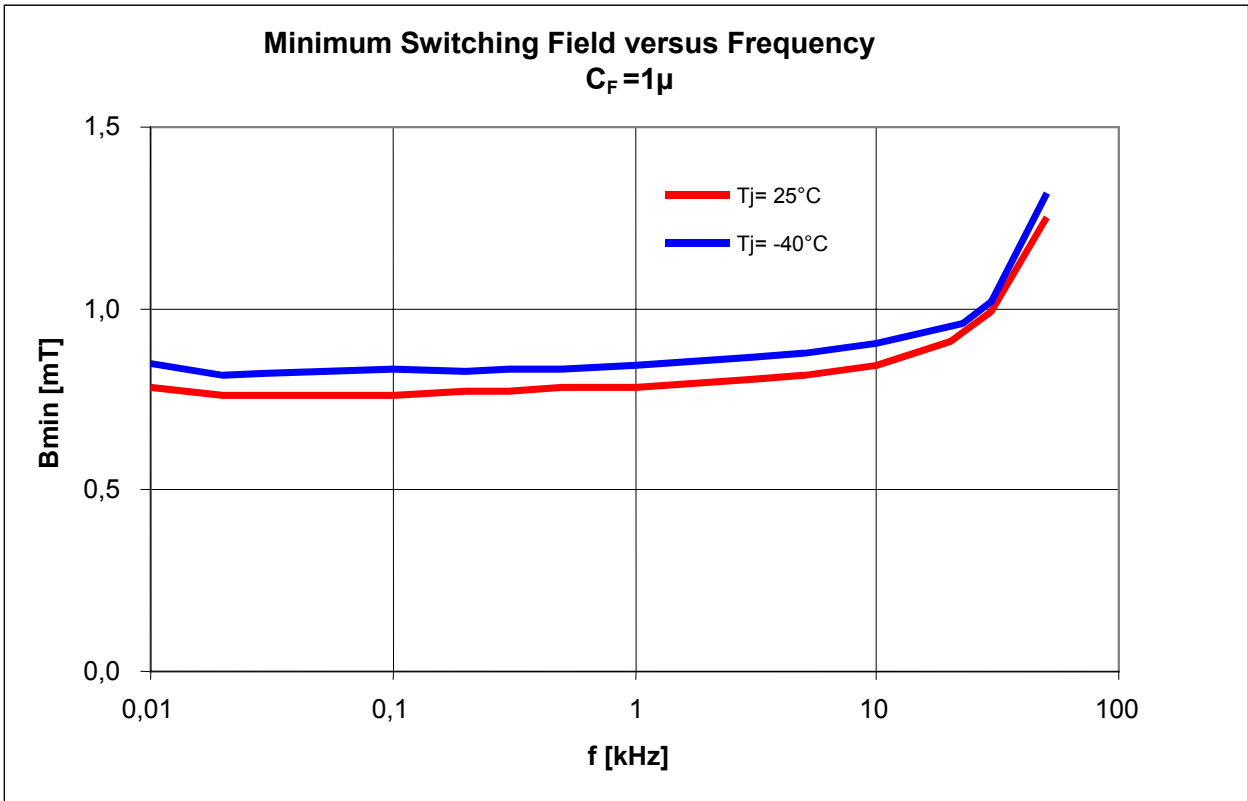


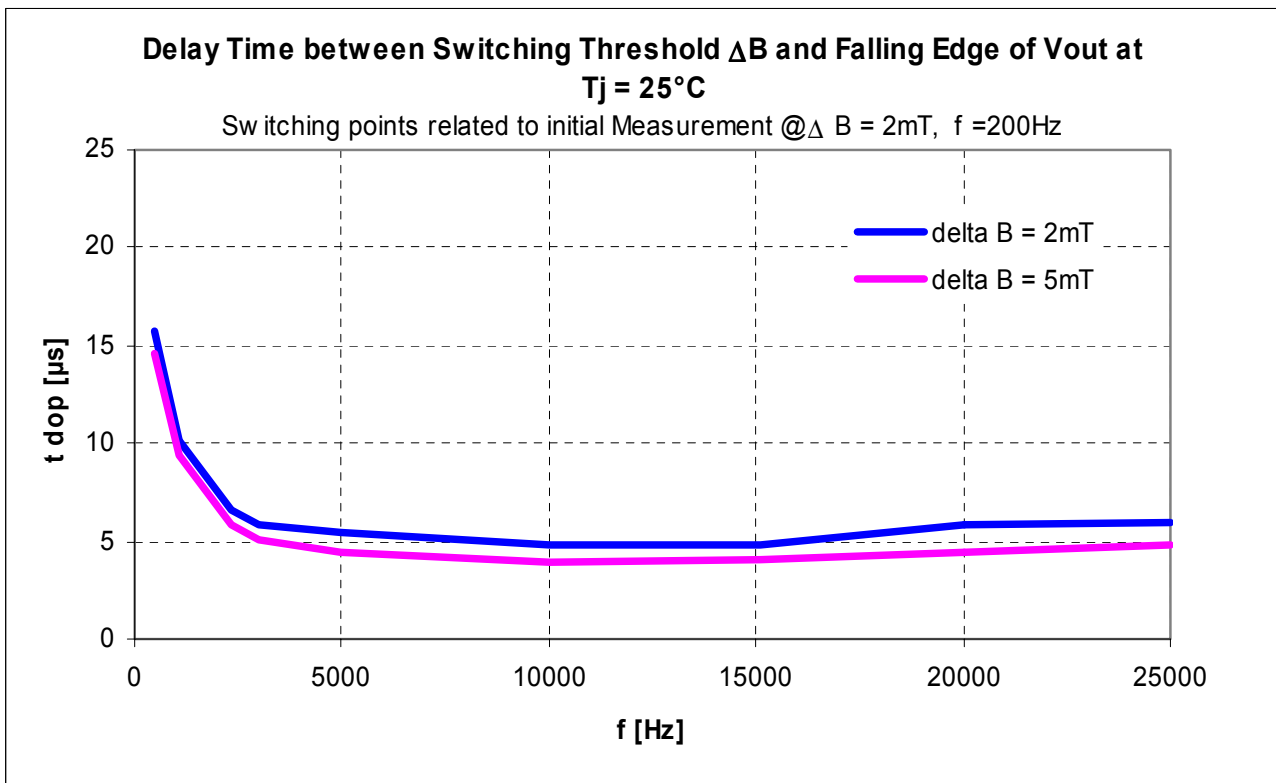
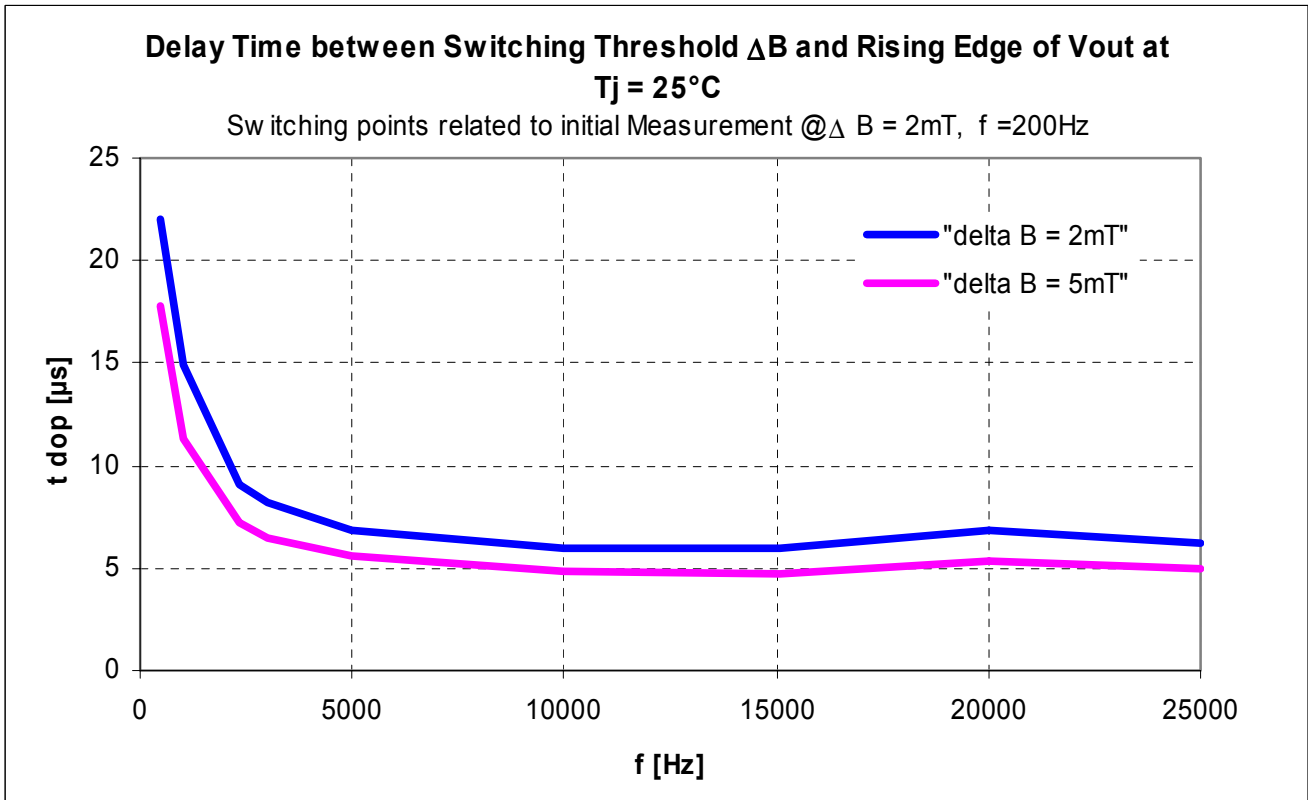


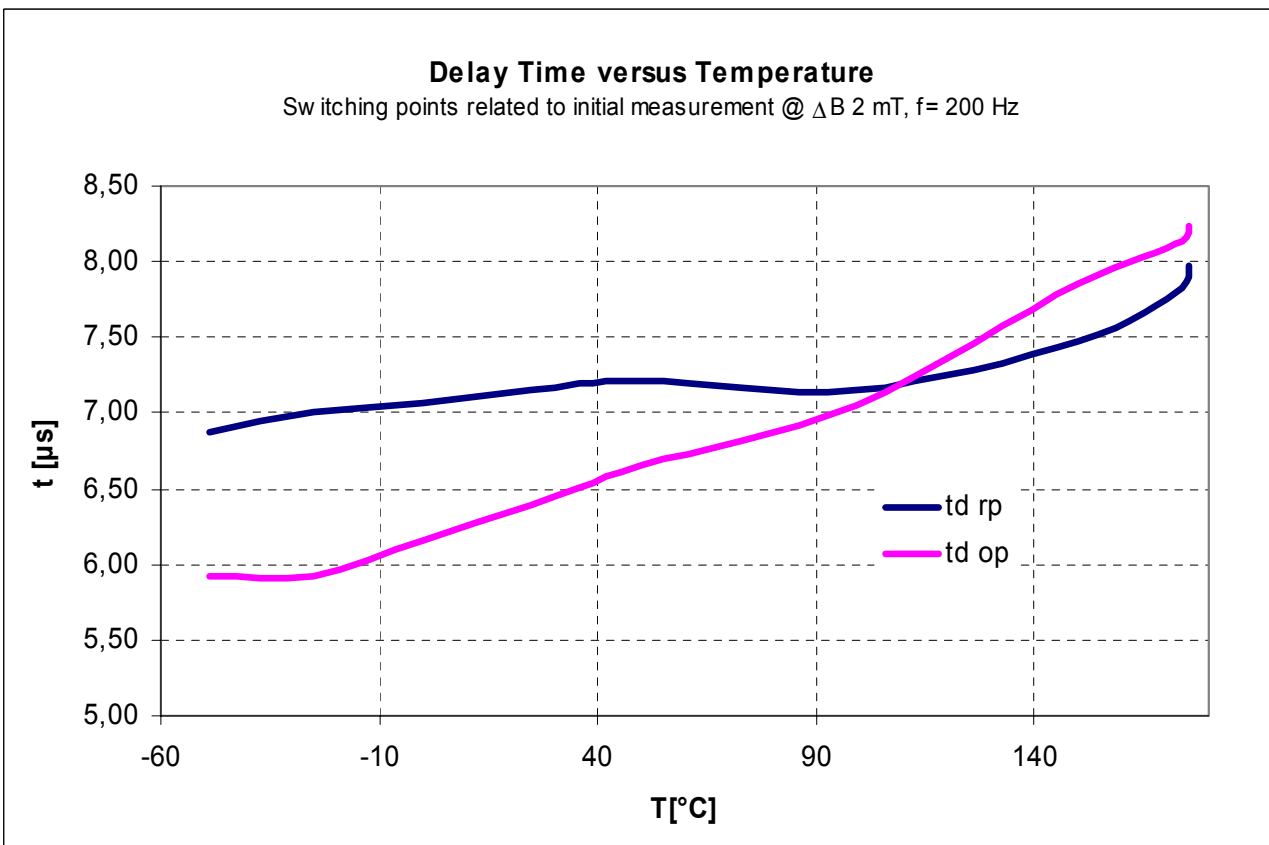
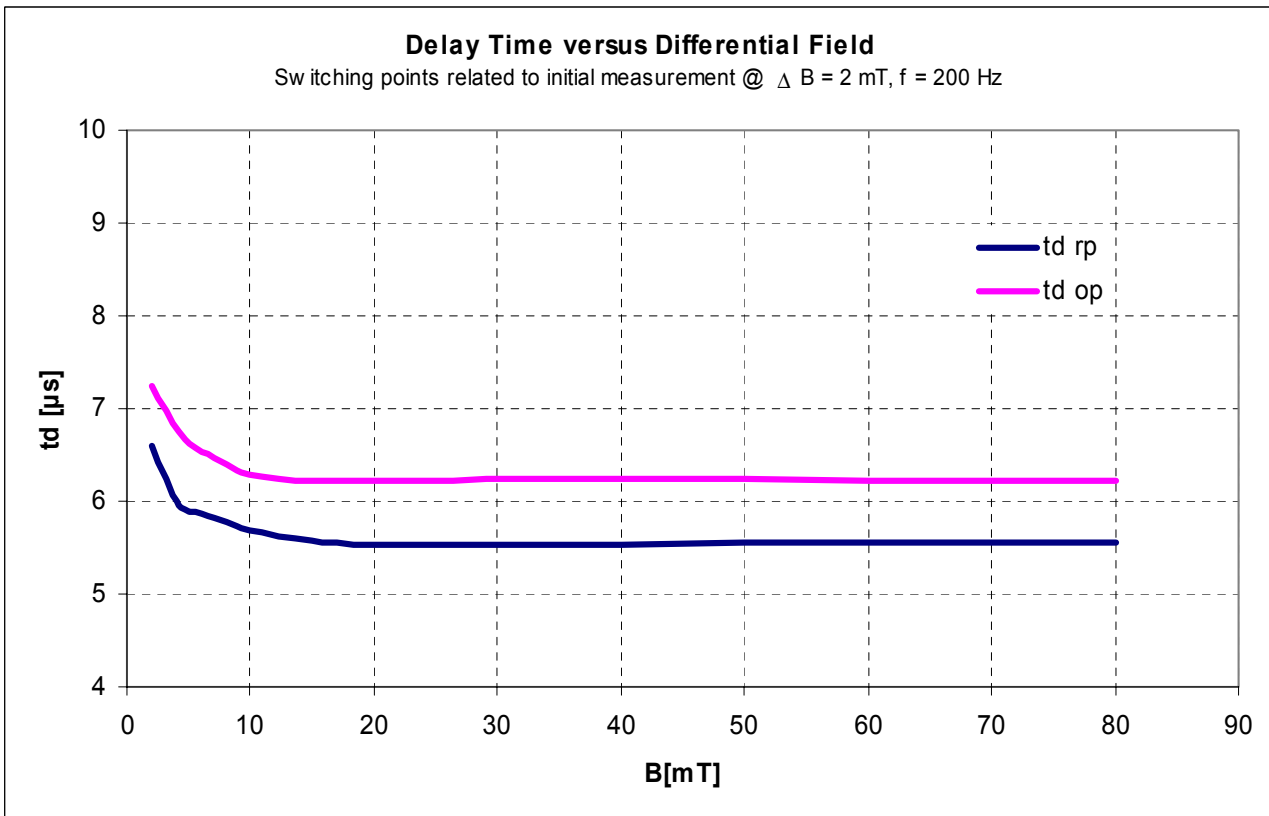


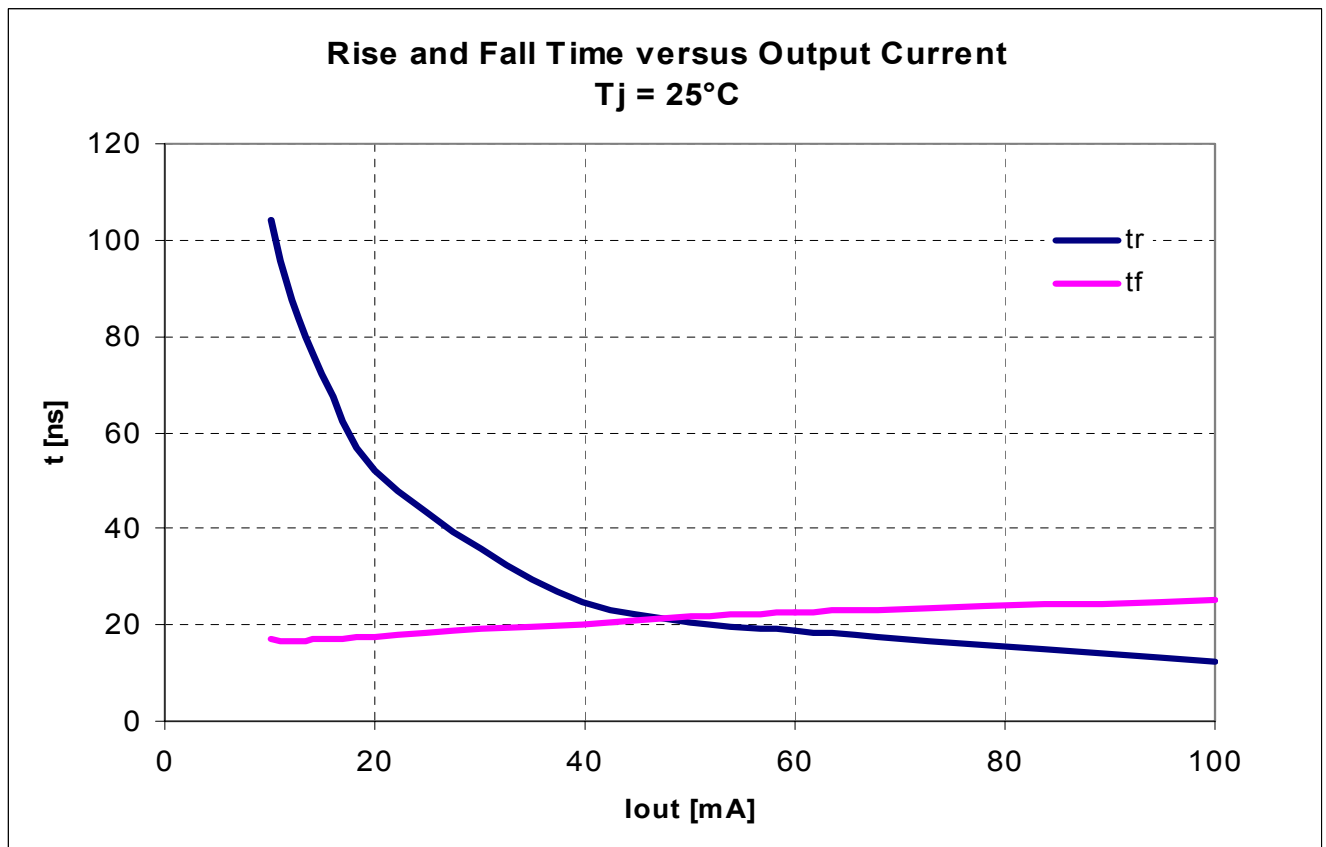
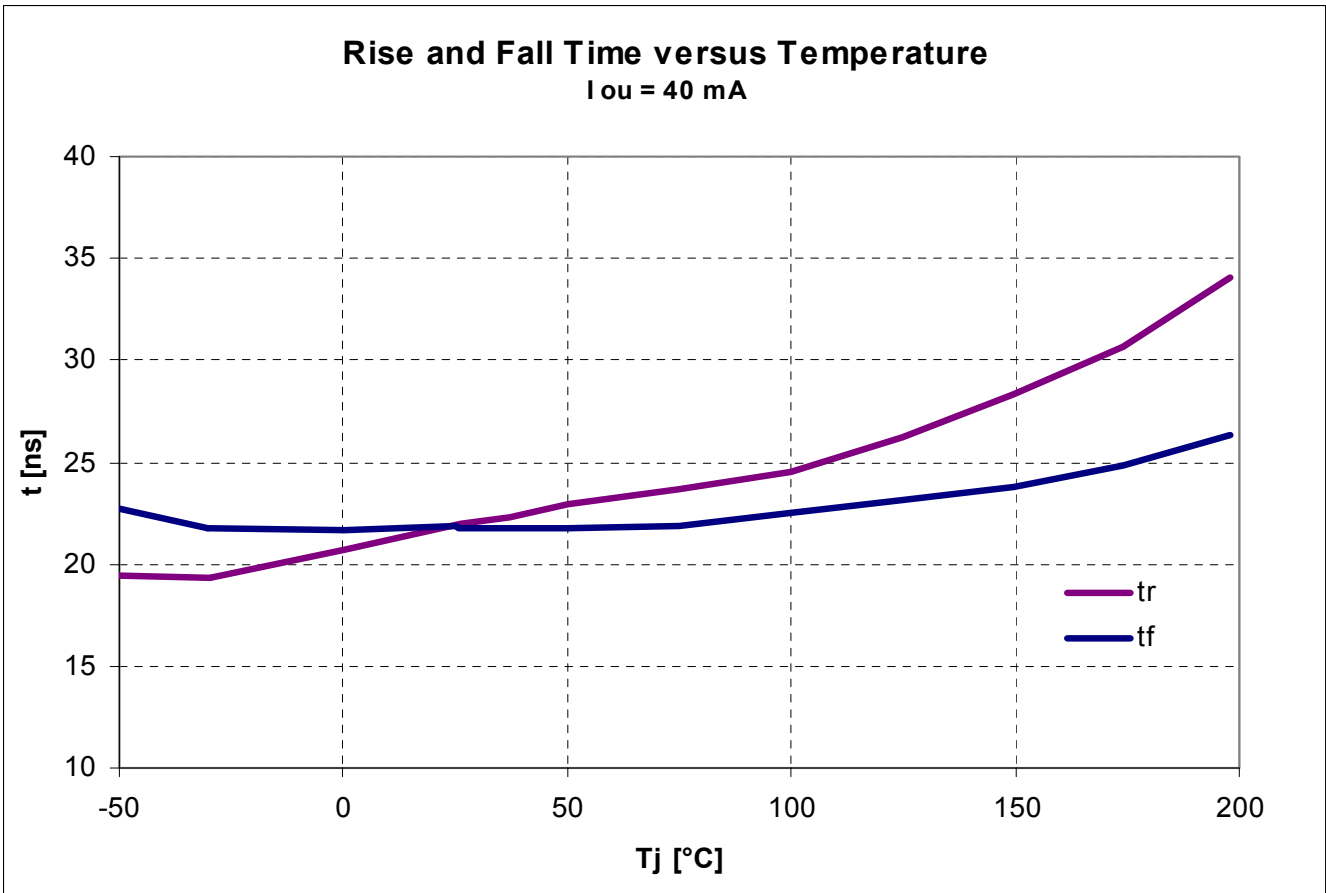


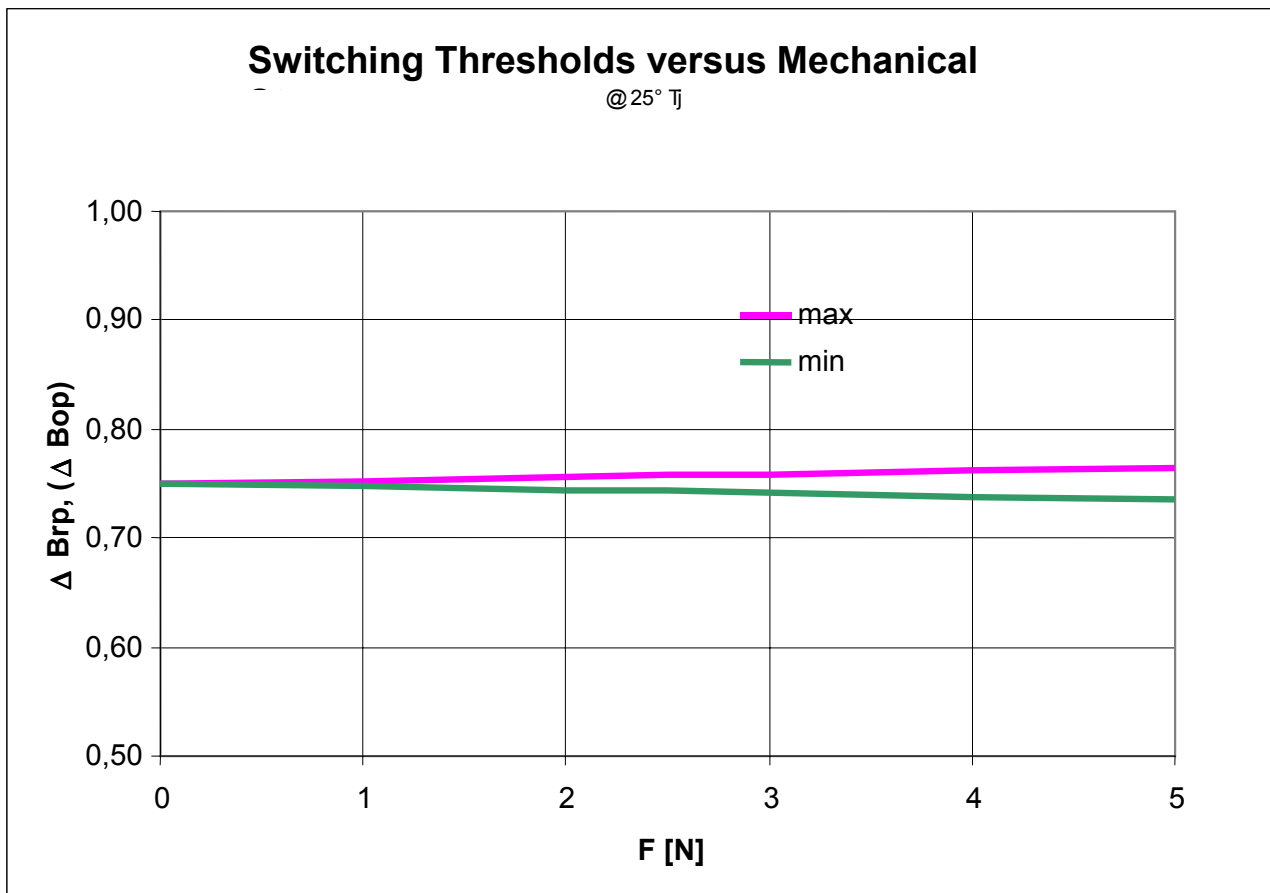
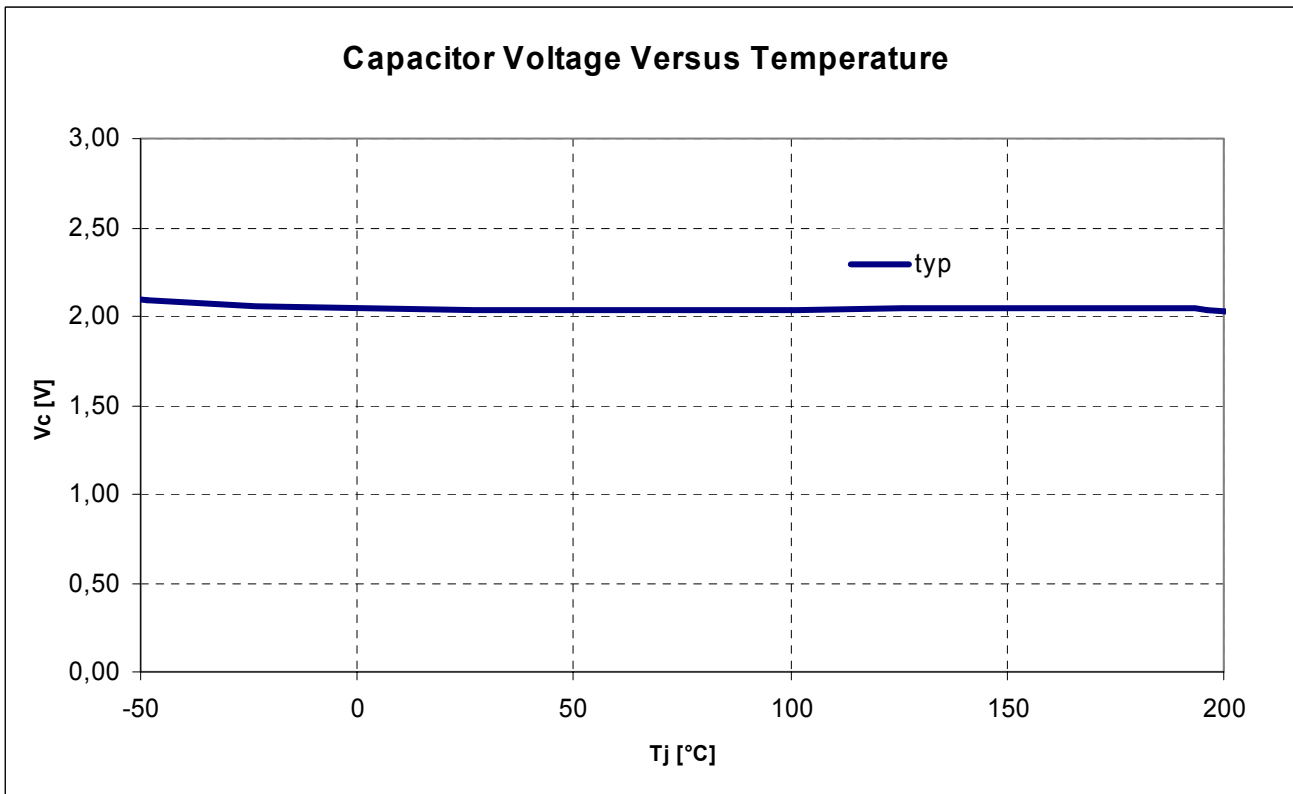


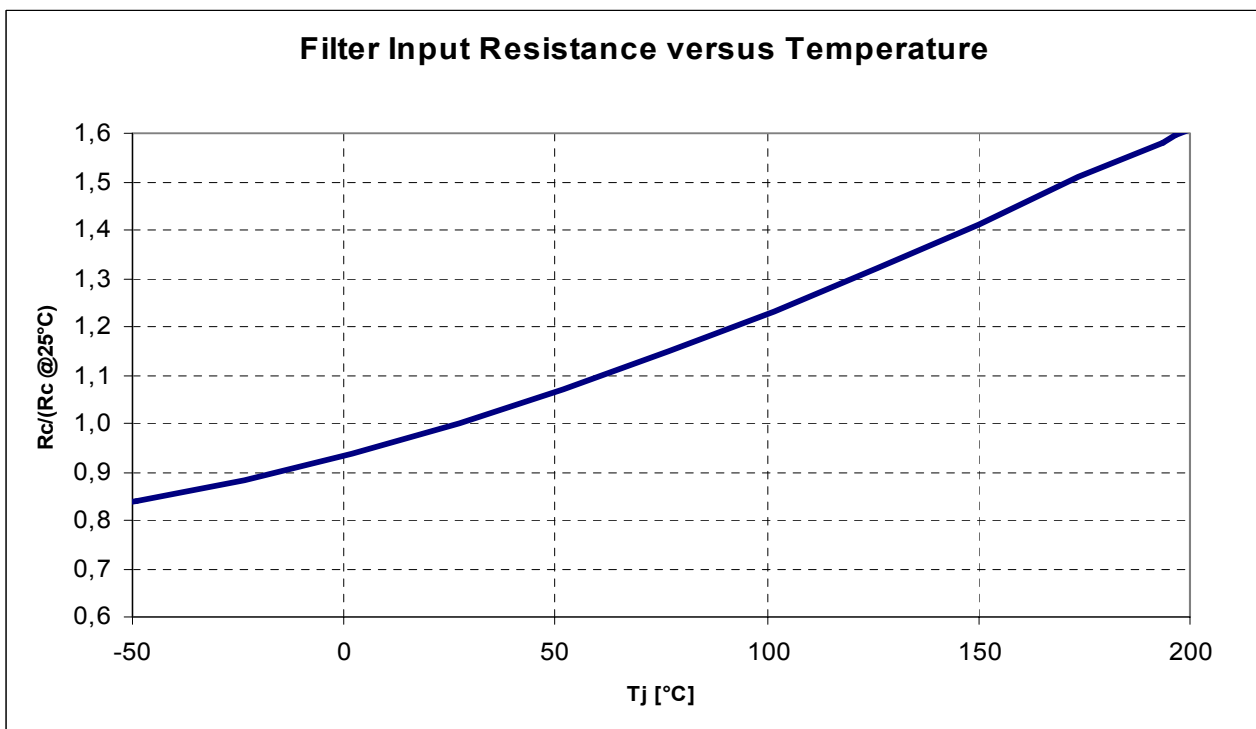
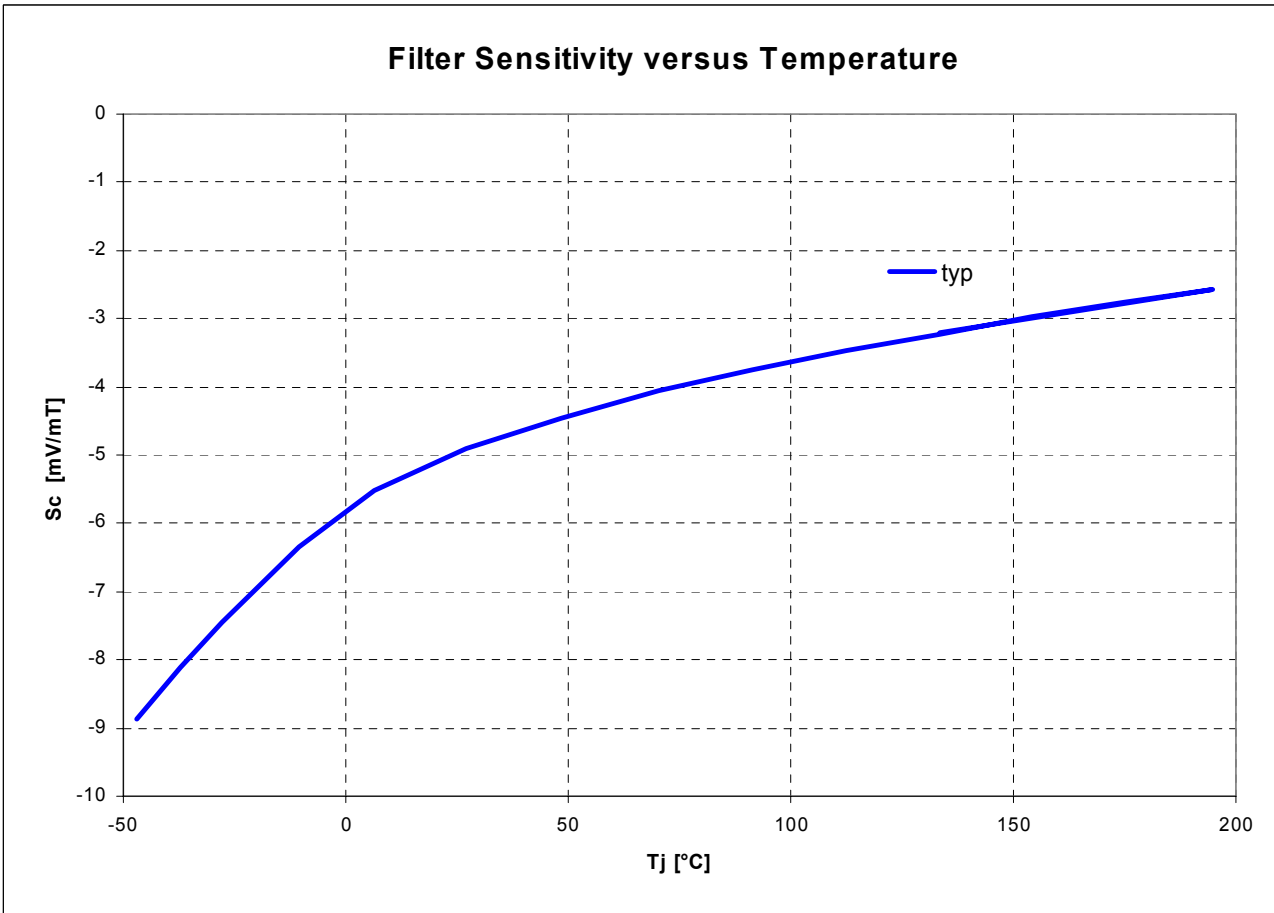


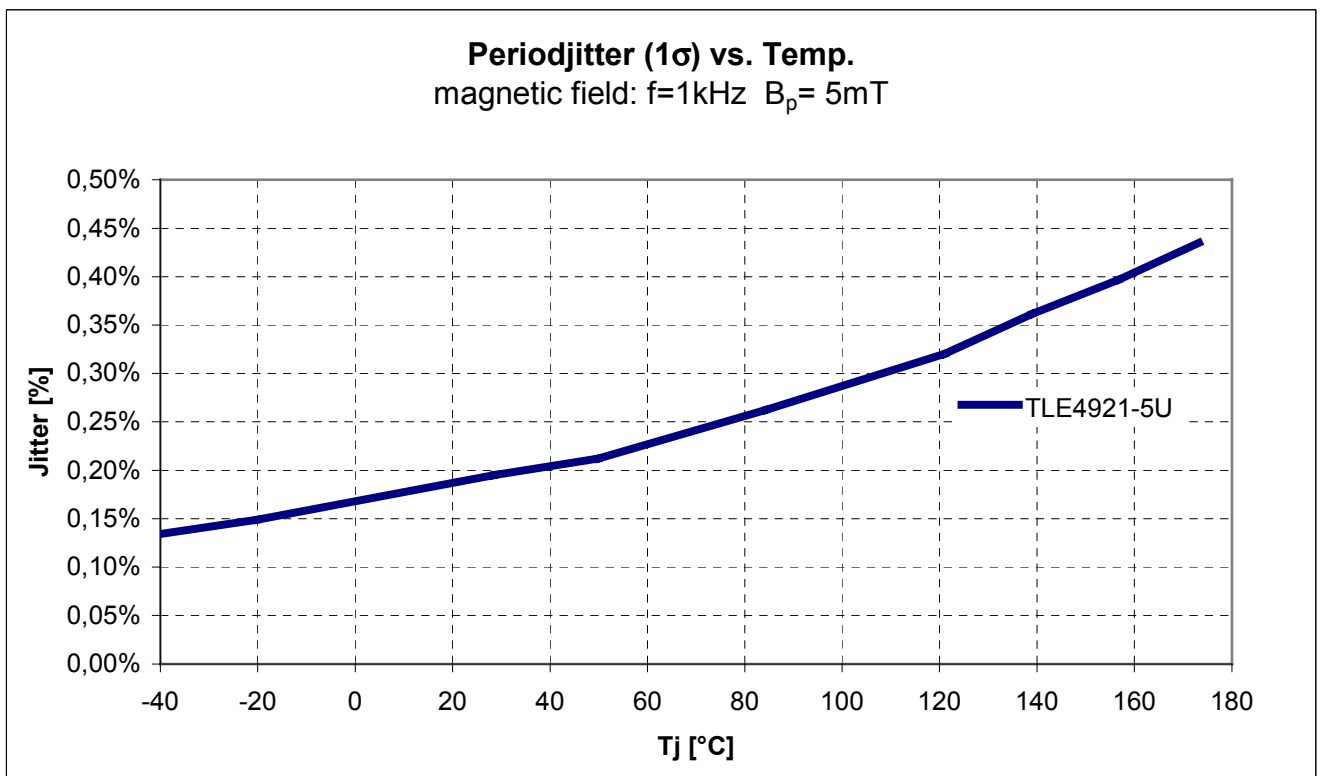
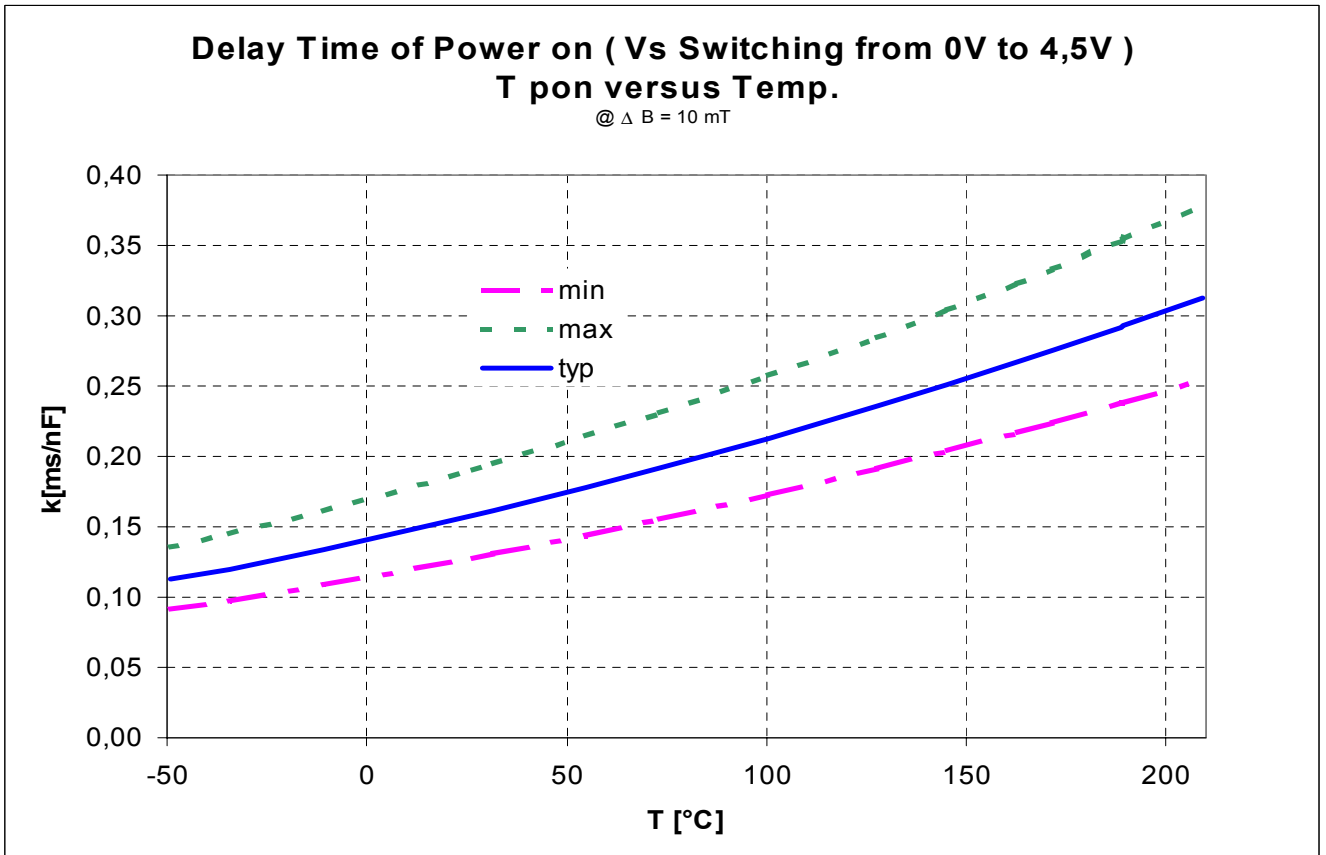






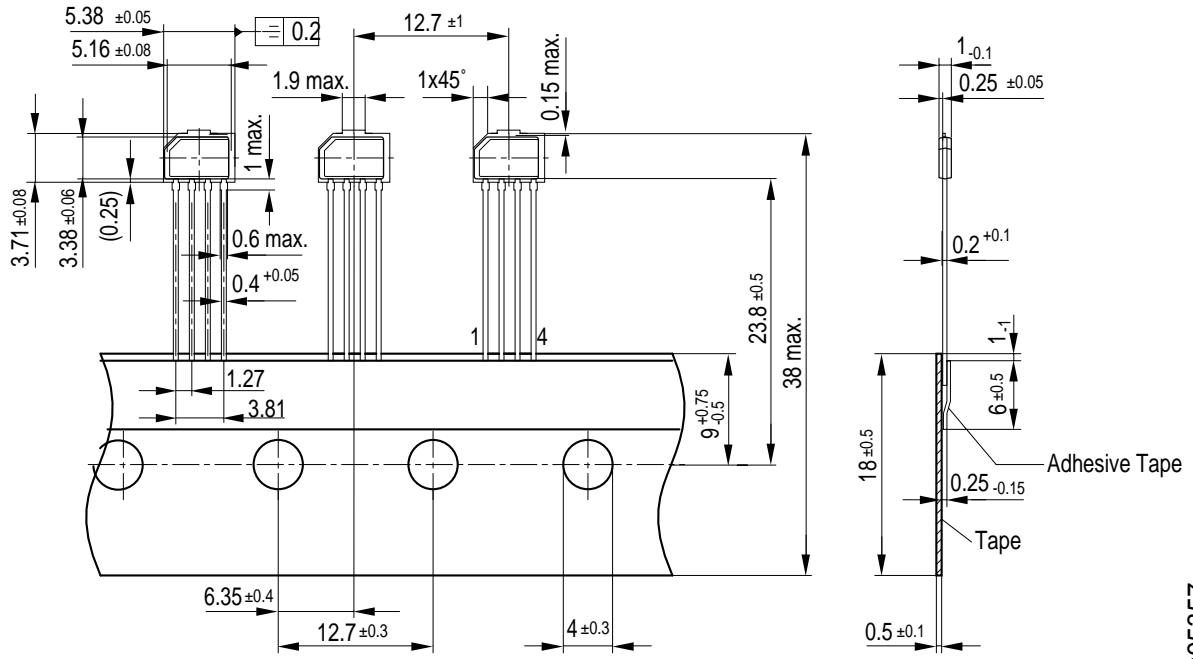




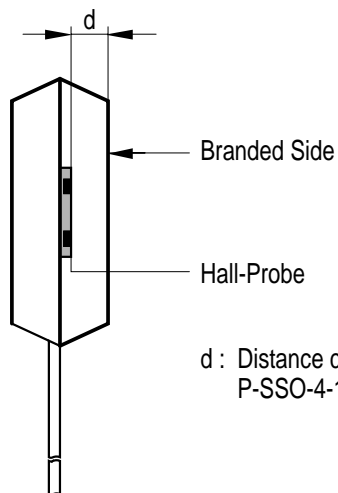


Package Outlines

**P-SSO-4-1**  
(Plastic Single Small Outline Package)



GPO05357



d : Distance chip to upper side of IC  
P-SSO-4-1 : 0.3 ±0.08 mm

AEA02712

**Sorts of Packing**

Package outlines for tubes, trays etc. are contained in our Data Book "Package Information".

Dimensions in mm