

2 Mb (256K x 8, Chip Erase) FLASH MEMORY

- 5V ± 10% SUPPLY VOLTAGE
- 12V PROGRAMMING VOLTAGE
- FAST ACCESS TIME: 70ns
- BYTE PROGRAMMING TIME: 10µs typical
- ELECTRICAL CHIP ERASE in 1s RANGE
- LOW POWER CONSUMPTION
 - Active Current: 15mA typical
 - Stand-by Current: 10µA typical
- 10,000 PROGRAM/ERASE CYCLES
- INTEGRATED ERASE/PROGRAM-STOP TIMER
- OTP COMPATIBLE PACKAGES and PINOUTS
- ELECTRONIC SIGNATURE
 - Manufacturer Code: 20h
 - Device Code: F4h

DESCRIPTION

The M28F201 FLASH Memory product is a non-volatile memories which may be erased electrically at the chip level and programmed byte-by-byte. It is organised as 256K bytes. It uses a command register architecture to select the operating modes and thus provide a simple microprocessor interface. The M28F201 FLASH Memory product is suitable for applications where the memory has to be reprogrammed in the equipment. The access time of 70ns makes the device suitable for use in high speed microprocessor systems.

Table 1. Signal Names

A0-A17	Address Inputs
DQ0-DQ7	Data Inputs / Outputs
\bar{E}	Chip Enable
\bar{G}	Output Enable
\bar{W}	Write Enable
V _{PP}	Program Supply
V _{CC}	Supply Voltage
V _{SS}	Ground

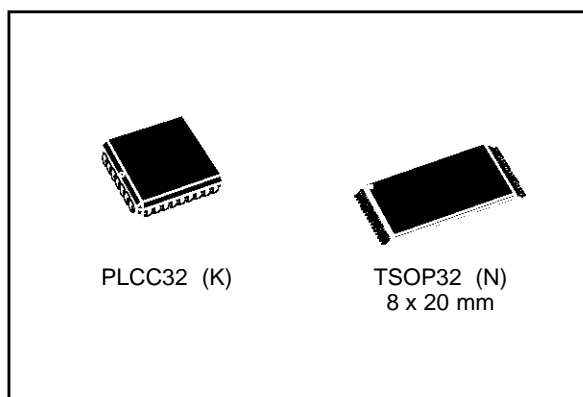

Figure 1. Logic Diagram

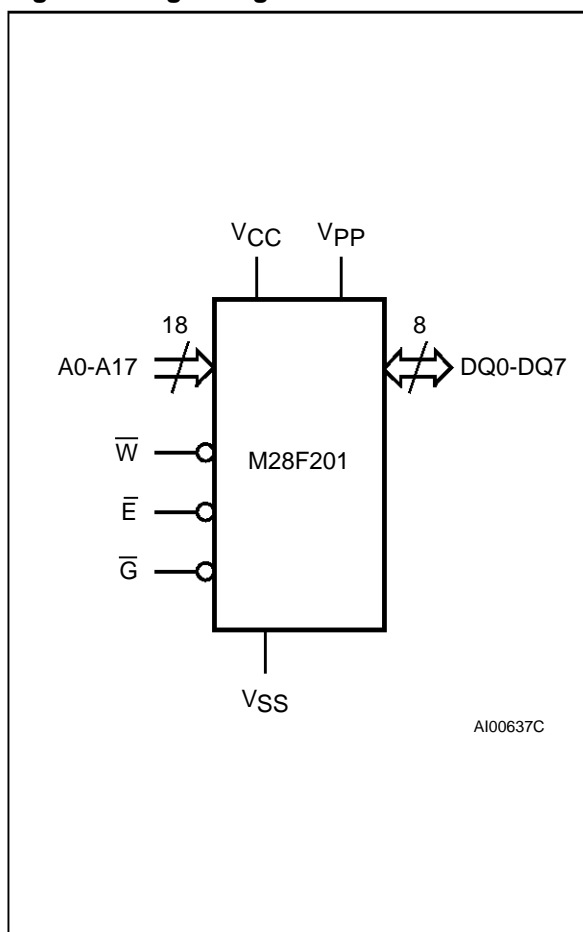

Figure 2A. LCC Pin Connections

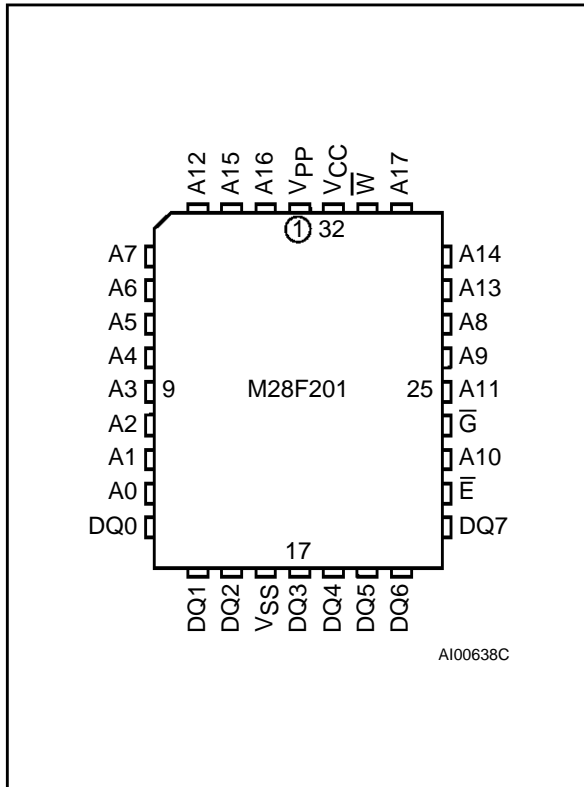

Figure 2B. TSOP Pin Connections

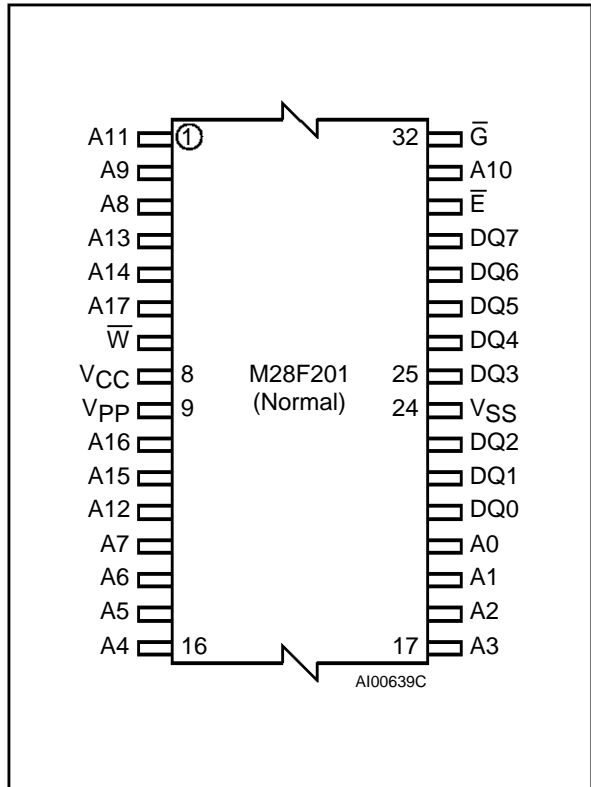
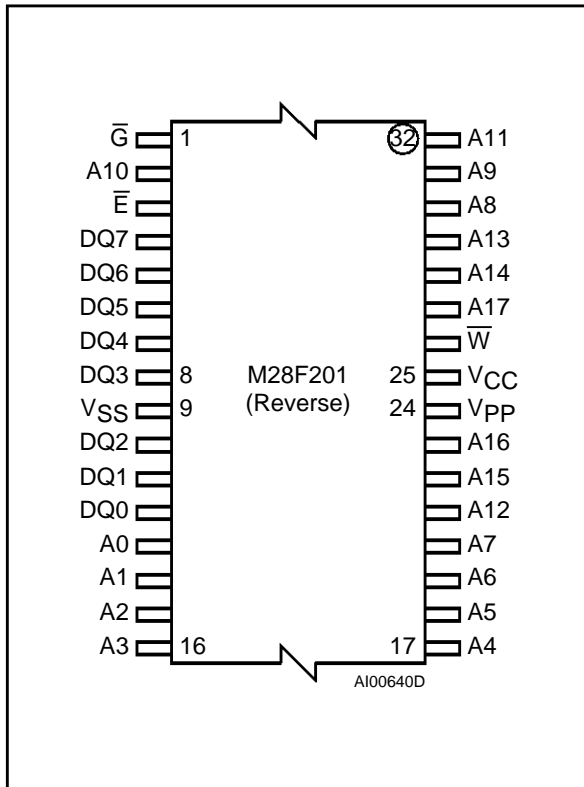

Figure 2C. TSOP Reverse Pin Connections



DEVICE OPERATION

The M28F201 FLASH Memory product employs a technology similar to a 2 Megabit EPROM but add to the device functionality by providing electrical erasure and programming. These functions are managed by a command register. The functions that are addressed via the command register depend on the voltage applied to the V_{PP}, program voltage, input. When V_{PP} is less than or equal to 6.5V, the command register is disabled and the M28F201 functions as a read only memory providing operating modes similar to an EPROM (Read, Output Disable, Electronic Signature Read and Standby). When V_{PP} is raised to 12V the command register is enabled and this provides, in addition, Erase and Program operations.

READ ONLY MODES, V_{PP} ≤ 6.5V

For all Read Only Modes, except Standby Mode, the Write Enable input \bar{W} should be High. In the Standby Mode this input is 'don't care'.

Read Mode. The M28F201 has two enable inputs, \bar{E} and \bar{G} , both of which must be Low in order to output data from the memory. The Chip Enable (\bar{E}) is the power control and should be used for device selection. Output Enable (\bar{G}) is the output control and should be used to gate data on to the output, independant of the device selection.



Table 2. Absolute Maximum Ratings

Symbol	Parameter	Value	Unit
T_A	Ambient Operating Temperature	-40 to 125	°C
T_{STG}	Storage Temperature	-65 to 150	°C
V_{IO}	Input or Output Voltages	-0.6 to 7	V
V_{CC}	Supply Voltage	-0.6 to 7	V
V_{A9}	A9 Voltage	-0.6 to 13.5	V
V_{PP}	Program Supply Voltage, during Erase or Programming	-0.6 to 14	V

Note: Except for the rating "Operating Temperature Range", stresses above those listed in the Table "Absolute Maximum Ratings" may cause permanent damage to the device. These are stress ratings only and operation of the device at these or any other conditions above those indicated in the Operating sections of this specification is not implied. Exposure to Absolute Maximum Rating conditions for extended periods may affect device reliability. Refer also to the SGS-THOMSON SURE Program and other relevant quality documents

Table 3. Operations (1)

	V_{PP}	Operation	\bar{E}	\bar{G}	\bar{W}	A9	DQ0 - DQ7
Read Only	V_{PPL}	Read	V_{IL}	V_{IL}	V_{IH}	A9	Data Output
		Output Disable	V_{IL}	V_{IH}	V_{IH}	X	Hi-Z
		Standby	V_{IH}	X	X	X	Hi-Z
		Electronic Signature	V_{IL}	V_{IL}	V_{IH}	V_{ID}	Codes
Read/Write (2)	V_{PPH}	Read	V_{IL}	V_{IL}	V_{IH}	A9	Data Output
		Write	V_{IL}	V_{IH}	V_{IL} Pulse	A9	Data Input
		Output Disable	V_{IL}	V_{IH}	V_{IH}	X	Hi-Z
		Standby	V_{IH}	X	X	X	Hi-Z

Notes: 1. X = V_{IL} or V_{IH} .
2. Refer also to the Command table.

Table 4. Electronic Signature

Identifier	A0	DQ7	DQ6	DQ5	DQ4	DQ3	DQ2	DQ1	DQ0	Hex Data
Manufacturer's Code	V_{IL}	0	0	1	0	0	0	0	0	20h
Device Code	V_{IH}	1	1	1	1	0	1	0	0	F4h

Table 5. Commands ⁽¹⁾

Command	Cycles	1st Cycle			2nd Cycle		
		Operation	A0-A17	DQ0-DQ7	Operation	A0-A17	DQ0-DQ7
Read	1	Write	X	00h			
Electronic Signature ⁽²⁾	2	Write	X	80h or 90h	Read	00000h	20h
					Read	00001h	F4h
Setup Erase/ Erase	2	Write	X	20h			
					Write	X	20h
Erase Verify	2	Write	A0-A17	A0h	Read	X	Data Output
Setup Program/ Program	2	Write	X	40h			
					Write	A0-A17	Data Input
Program Verify	2	Write	X	C0h	Read	X	Data Output
Reset	2	Write	X	FFh	Write	X	FFh

Notes: 1. X = V_{IL} or V_{IH} .
2. Refer also to the Electronic Signature table.

Standby Mode. In the Standby Mode the maximum supply current is reduced. The device is placed in the Standby Mode by applying a High level to the Chip Enable (\bar{E}) input. When in the Standby Mode the outputs are in a high impedance state, independent of the Output Enable (\bar{G}) input.

Output Disable Mode. When the Output Enable (\bar{G}) is High the outputs are in a high impedance state.

Electronic Signature Mode. This mode allows the read out of two binary codes from the device which identify the manufacturer and device type. This mode is intended for use by programming equipment to automatically select the correct erase and programming algorithms. The Electronic Signature Mode is active when a high voltage (11.5V to 13V) is applied to address line A9 with \bar{E} and \bar{G} Low. With A0 Low the output data is the manufacturer code, when A0 is High the output is the device code. All other address lines should be maintained Low while reading the codes. The electronic signature can also be accessed in Read/Write modes.

READ/WRITE MODES, $11.4V \leq V_{PP} \leq 12.6V$

When V_{PP} is High both read and write operations may be performed. These are defined by the contents of an internal command register. Commands may be written to this register to set-up and execute, Erase, Erase Verify, Program, Program Verify and Reset modes. Each of these modes needs 2 cycles. Each mode starts with a write operation to set-up the command, this is followed by either read or write operations. The device expects the first cycle to be a write operation and does not corrupt

data at any location in the memory. Read mode is set-up with one cycle only and may be followed by any number of read operations to output data. Electronic Signature Read mode is set-up with one cycle and followed by a read cycle to output the manufacturer or device codes.

A write to the command register is made by bringing \bar{W} Low while \bar{E} is Low. The falling edge of \bar{W} latches Addresses, while the rising edge latches Data, which are used for those commands that require address inputs, command input or provide data output. The supply voltage V_{CC} and the program voltage V_{PP} can be applied in any order. When the device is powered up or when V_{PP} is $\leq 6.5V$ the contents of the command register defaults to 00h, thus automatically setting-up Read operations. In addition a specific command may be used to set the command register to 00h for reading the memory. The system designer may choose to provide a constant high V_{PP} and use the register commands for all operations, or to switch the V_{PP} from low to high only when needing to erase or program the memory. All command register access is inhibited when V_{CC} falls below the Erase/Write Lockout Voltage (V_{LKO}) of 2.5V.

If the device is deselected during Erasure, Programming or verifying it will draw active supply currents until the operations are terminated.

The device is protected against stress caused by long erase or program times. If the end of Erase or Programming operations are not terminated by a Verify cycle within a maximum time permitted, an internal stop timer automatically stops the operation. The device remains in an inactive state, ready to start a Verify or Reset Mode operation.

Table 6. AC Measurement Conditions

	SRAM Interface Levels	EPROM Interface Levels
Input Rise and Fall Times	≤ 10ns	≤ 10ns
Input Pulse Voltages	0 to 3V	0.45V to 2.4V
Input and Output Timing Ref. Voltages	1.5V	0.8V and 2V

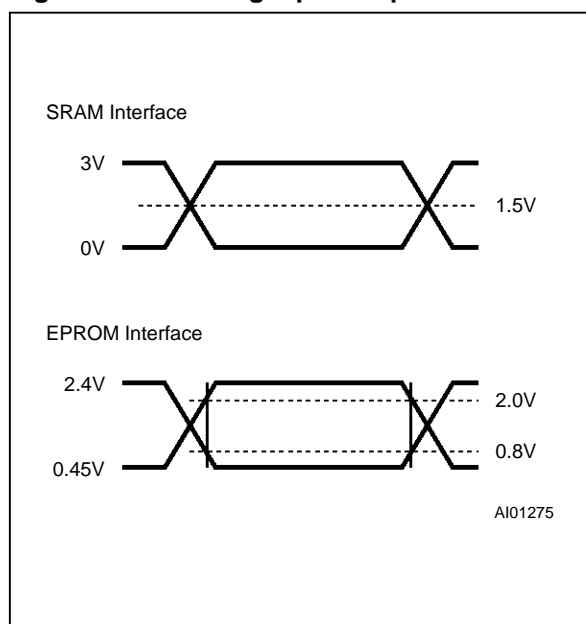
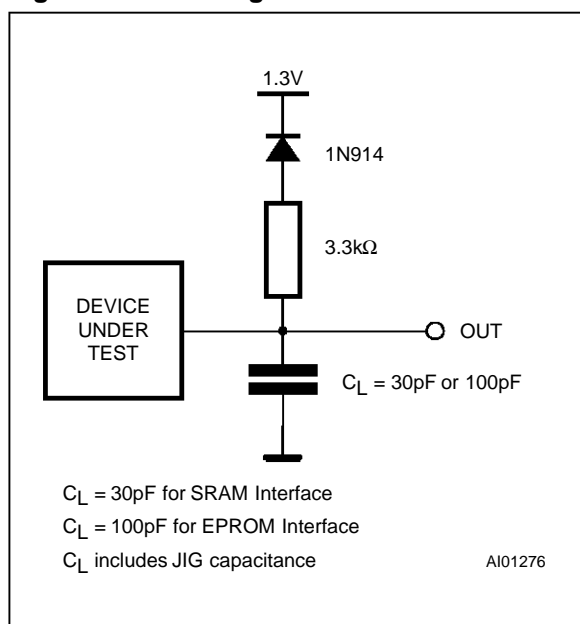
Figure 3. AC Testing Input Output Waveform**Figure 4. AC Testing Load Circuit****Table 7. Capacitance⁽¹⁾ (T_A = 25 °C, f = 1 MHz)**

Symbol	Parameter	Test Condition	Min	Max	Unit
C _{IN}	Input Capacitance	V _{IN} = 0V		6	pF
C _{OUT}	Output Capacitance	V _{OUT} = 0V		12	pF

Note: 1. Sampled only, not 100% tested.

Read Mode. The Read Mode is the default at power up or may be set-up by writing 00h to the command register. Subsequent read operations output data from the memory. The memory remains in the Read Mode until a new command is written to the command register.

Electronic Signature Mode. In order to select the correct erase and programming algorithms for on-board programming, the manufacturer and device

codes may be read directly. It is not necessary to apply a high voltage to A9 when using the command register. The Electronic Signature Mode is set-up by writing 80h or 90h to the command register. The following read cycles, with address inputs 00000h or 00001h, output the manufacturer or device codes. The command is terminated by writing another valid command to the command register (for example Reset).

Table 8. DC Characteristics(T_A = 0 to 70 °C, –40 to 85 °C or –40 to 125 °C; V_{CC} = 5V ± 10%)

Symbol	Parameter	Test Condition	Min	Max	Unit
I _{LI}	Input Leakage Current	0V ≤ V _{IN} ≤ V _{CC}		±1	μA
I _{LO}	Output Leakage Current	0V ≤ V _{OUT} ≤ V _{CC}		±10	μA
I _{CC}	Supply Current (Read)	$\bar{E} = V_{IL}$, f = 10MHz		30	mA
I _{CC1}	Supply Current (Standby) TTL	$\bar{E} = V_{IH}$		1	mA
	Supply Current (Standby) CMOS	$\bar{E} = V_{CC} \pm 0.2V$		100	μA
I _{CC2} ⁽¹⁾	Supply Current (Programming)	During Programming		10	mA
I _{CC3} ⁽¹⁾	Supply Current (Program Verify)	During Verify		20	mA
I _{CC4} ⁽¹⁾	Supply Current (Erase)	During Erasure		20	mA
I _{CC5} ⁽¹⁾	Supply Current (Erase Verify)	During Erase Verify		20	mA
I _{LPP}	Program Leakage Current	V _{PP} ≤ V _{CC}		±10	μA
I _{PP}	Program Current (Read or Standby)	V _{PP} > V _{CC}		200	μA
		V _{PP} ≤ V _{CC}		±10	μA
I _{PP1} ⁽¹⁾	Program Current (Programming)	V _{PP} = V _{PPH} , During Programming		30	mA
I _{PP2} ⁽¹⁾	Program Current (Program Verify)	V _{PP} = V _{PPH} , During Verify		5	mA
I _{PP3} ⁽¹⁾	Program Current (Erase)	V _{PP} = V _{PPH} , During Erase		30	mA
I _{PP4} ⁽¹⁾	Program Current (Erase Verify)	V _{PP} = V _{PPH} , During Erase Verify		5	mA
V _{IL}	Input Low Voltage		–0.5	0.8	V
V _{IH}	Input High Voltage TTL		2	V _{CC} + 0.5	V
	Input High Voltage CMOS		0.7 V _{CC}	V _{CC} + 0.5	V
V _{OL}	Output Low Voltage	I _{OL} = 5.8mA		0.45	V
V _{OH}	Output High Voltage CMOS	I _{OH} = –100μA	V _{CC} – 0.4		V
		I _{OH} = –2.5mA	0.85 V _{CC}		V
	Output High Voltage TTL	I _{OH} = –2.5mA	2.4		V
V _{PPL}	Program Voltage (Read Operations)		0	6.5	V
V _{PPH}	Program Voltage (Read/Write Operations)		11.4	12.6	V
V _{ID}	A9 Voltage (Electronic Signature)		11.5	13	V
I _{ID} ⁽¹⁾	A9 Current (Electronic Signature)	A9 = V _{ID}		200	μA
V _{LKO}	Supply Voltage, Erase/Program Lock-out		2.5		V

Note: 1. Not 100% tested. Characterisation Data available.

Table 9. Read Only Mode AC Characteristics
 (($T_A = 0$ to 70 °C, -40 to 85 °C or -40 to 125 °C)

Symbol	Alt	Parameter	Test Condition	M28F201								Unit
				-70		-90		-120		-150		
				$V_{CC} = 5V \pm 10\%$		$V_{CC} = 5V \pm 10\%$		$V_{CC} = 5V \pm 10\%$		$V_{CC} = 5V \pm 10\%$		
				EPROM Interface		EPROM Interface		EPROM Interface		EPROM Interface		
				Min	Max	Min	Max	Min	Max	Min	Max	
t_{WHGL}		Write Enable High to Output Enable Low		6		6		6		6		μs
t_{AVAV}	t_{RC}	Read Cycle Time	$\bar{E} = V_{IL}, \bar{G} = V_{IL}$	70		90		120		150		ns
t_{AVQV}	t_{ACC}	Address Valid to Output Valid	$\bar{E} = V_{IL}, \bar{G} = V_{IL}$		70		90		120		150	ns
$t_{ELQX}^{(1)}$	t_{LZ}	Chip Enable Low to Output Transition	$\bar{G} = V_{IL}$	0		0		0		0		ns
t_{ELQV}	t_{CE}	Chip Enable Low to Output Valid	$\bar{G} = V_{IL}$		70		90		120		150	ns
$t_{GLQX}^{(1)}$	t_{OLZ}	Output Enable Low to Output Transition	$\bar{E} = V_{IL}$	0		0		0		0		ns
t_{GLQV}	t_{OE}	Output Enable Low to Output Valid	$\bar{E} = V_{IL}$		25		30		35		40	ns
$t_{EHQZ}^{(1)}$		Chip Enable High to Output Hi-Z	$\bar{G} = V_{IL}$	0	25	0	30	0	30	0	35	ns
$t_{GHQZ}^{(1)}$	t_{DF}	Output Enable High to Output Hi-Z	$\bar{E} = V_{IL}$	0	25	0	30	0	30	0	35	ns
t_{AXQX}	t_{OH}	Address Transition to Output Transition	$\bar{E} = V_{IL}, \bar{G} = V_{IL}$	0		0		0		0		ns

Note: 1. Sampled only, not 100% tested

Erase and Erase Verify Modes. The memory is erased by first Programming all bytes to 00h, the Erase command then erases them to FFh. The Erase Verify command is then used to read the memory byte-by-byte for a content of FFh. The Erase Mode is set-up by writing 20h to the command register. The write cycle is then repeated to start the erase operation. Erasure starts on the rising edge of \bar{W} during this second cycle. Erase is followed by an Erase Verify which reads an addressed byte. Erase Verify Mode is set-up by writing A0h to the command register and at the same time supplying the address of the byte to be verified. The rising edge of \bar{W} during the set-up of the first Erase Verify Mode stops the Erase operation.

The following read cycle is made with an internally generated margin voltage applied; reading FFh indicates that all bits of the addressed byte are fully erased. The whole contents of the memory are verified by repeating the Erase Verify Operation, first writing the set-up code A0h with the address of the byte to be verified and then reading the byte contents in a second read cycle.

As the Erase algorithm flow chart shows, when the data read during Erase Verify is not FFh, another Erase operation is performed and verification continues from the address of the last verified byte. The command is terminated by writing another valid command to the command register (for example Program or Reset).

Figure 5. Read Mode AC Waveforms

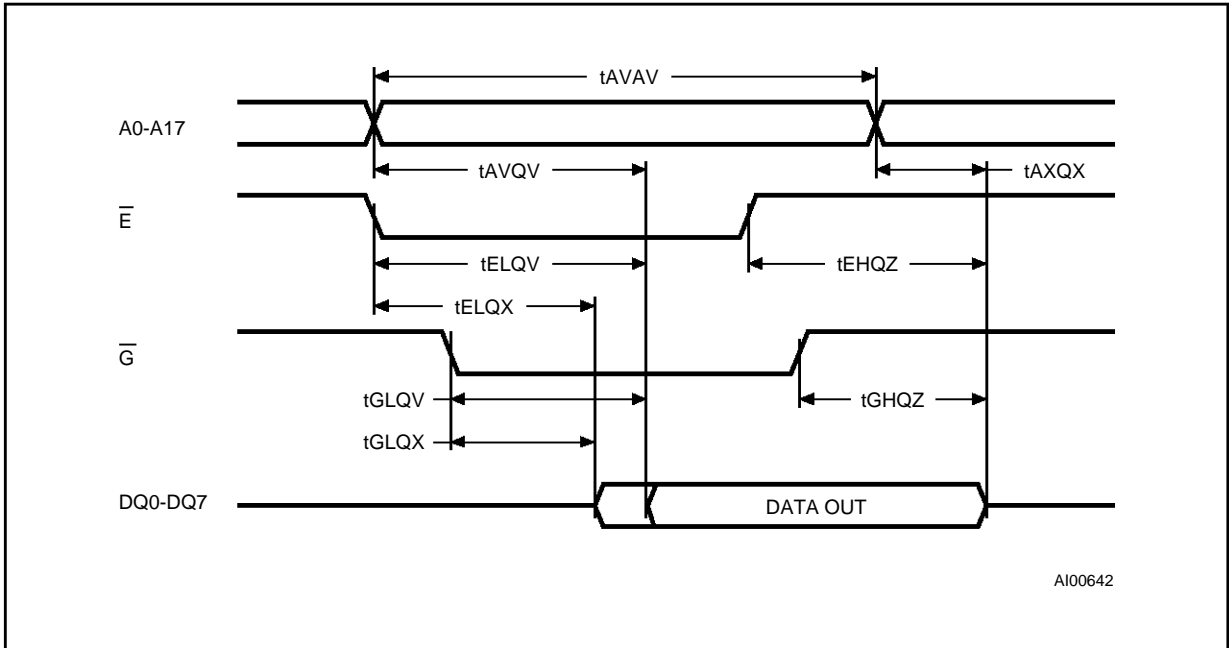

Figure 6. Read Command Waveforms

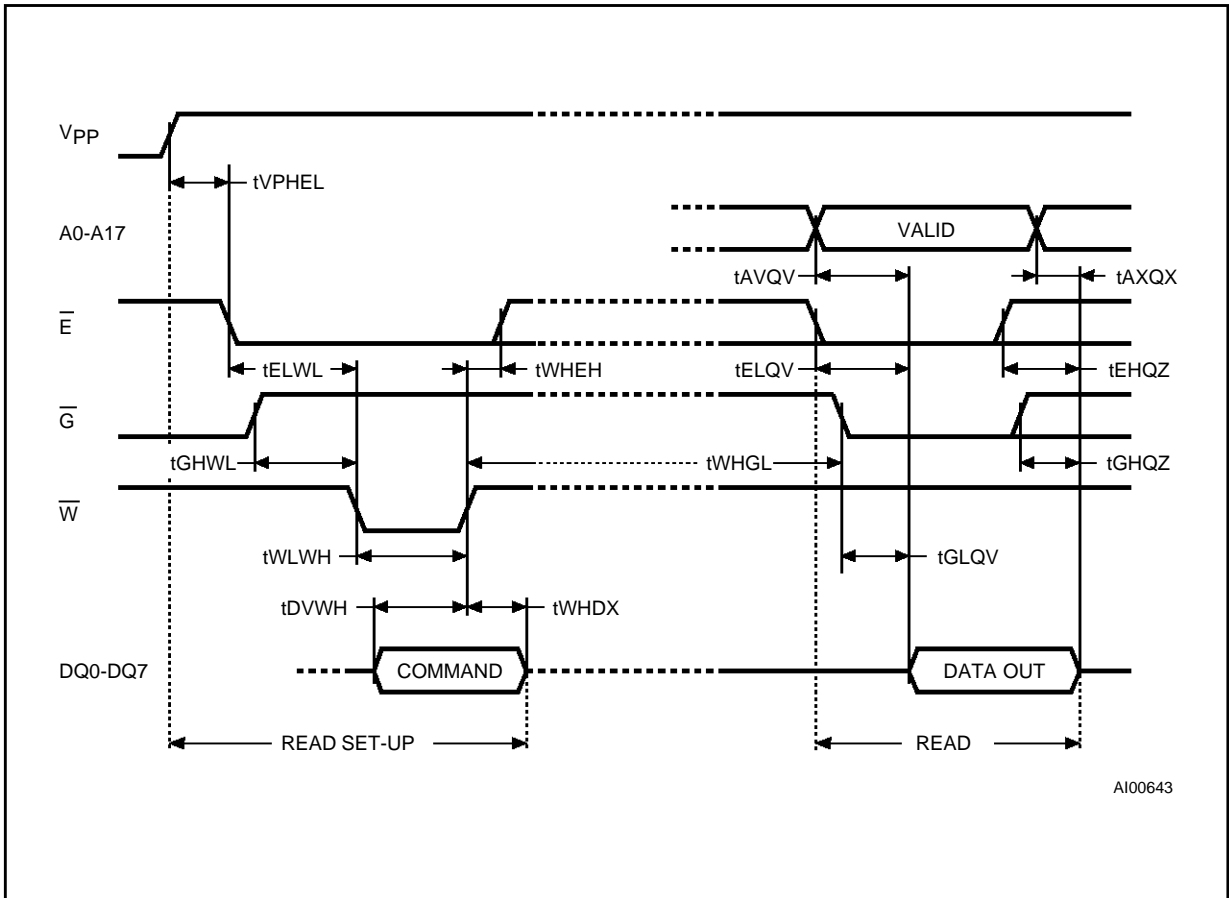
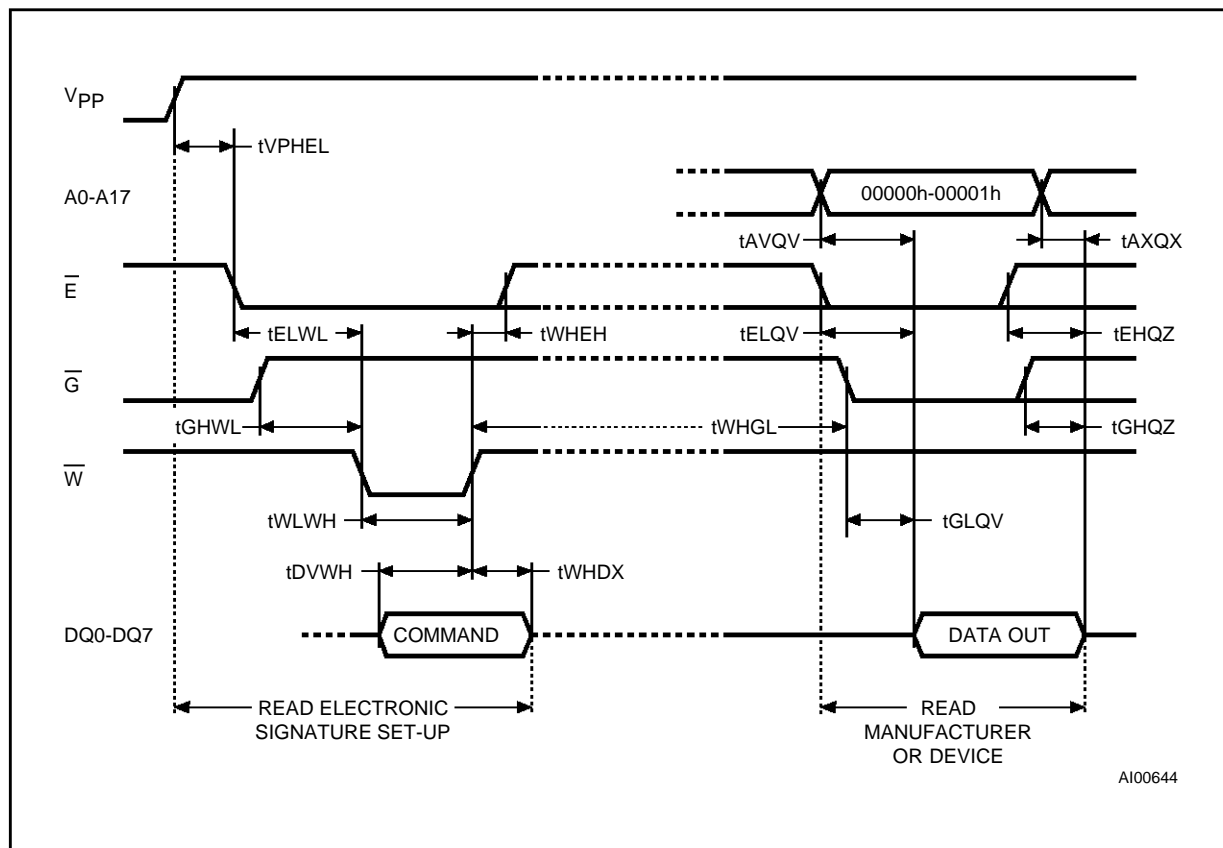

Figure 7. Electronic Signature Command Waveforms



Program and Program Verify Modes. The Program Mode is set-up by writing 40h to the command register. This is followed by a second write cycle which latches the address and data of the byte to be programmed. The rising edge of \overline{W} during this second cycle starts the programming operation. Programming is followed by a Program Verify of the data written.

Program Verify Mode is set-up by writing C0h to the command register. The rising edge of \overline{W} during the set-up of the Program Verify Mode stops the Pro-

gramming operation. The following read cycle, of the address already latched during programming, is made with an internally generated margin voltage applied, reading valid data indicates that all bits have been programmed.

Reset Mode. This command is used to safely abort Erase or Program Modes. The Reset Mode is set-up and performed by writing FFh two times to the command register. The command should be followed by writing a valid command to the the command register (for example Read).

Table 10A. Read/Write Mode AC Characteristics, \overline{W} and \overline{E} Controlled
 ($T_A = 0$ to 70 °C, -40 to 85 °C or -40 to 125 °C)

Symbol	Alt	Parameter	M28F201				Unit
			-70		-90		
			$V_{CC} = 5V \pm 10\%$		$V_{CC} = 5V \pm 10\%$		
			EPROM Interface		EPROM Interface		
Min	Max	Min	Max				
t _{VPHEL}		V _{PP} High to Chip Enable Low	1		1		μs
t _{VPHWL}		V _{PP} High to Write Enable Low	1		1		μs
t _{WHWH3}	t _{WC}	Write Cycle Time (\overline{W} controlled)	70		90		ns
t _{EH3}	t _{WC}	Write Cycle Time (\overline{E} controlled)	70		90		ns
t _{AVWL}	t _{AS}	Address Valid to Write Enable Low	0		0		ns
t _{AVEL}		Address Valid to Chip Enable Low	0		0		ns
t _{WLAX}	t _{AH}	Write Enable Low to Address Transition	30		45		ns
t _{ELAX}		Chip Enable Low to Address Transition	30		45		ns
t _{ELWL}	t _{CS}	Chip Enable Low to Write Enable Low	0		0		ns
t _{WLEL}		Write Enable Low to Chip Enable Low	0		0		ns
t _{GHWL}		Output Enable High to Write Enable Low	0		0		μs
t _{GHEL}		Output Enable High to Chip Enable Low	0		0		μs
t _{DVWH}	t _{DS}	Input Valid to Write Enable High	30		45		ns
t _{DVEH}		Input Valid to Chip Enable High	30		45		ns
t _{WLWH}	t _{WP}	Write Enable Low to Write Enable High (Write Pulse)	30		45		ns
t _{LEH}		Chip Enable Low to Chip Enable High (Write Pulse)	50		60		ns
t _{WHDX}	t _{DH}	Write Enable High to Input Transition	10		10		ns
t _{EHD}		Chip Enable High to Input Transition	10		10		ns
t _{WHWH1}		Duration of Program Operation (\overline{W} contr.)	10		10		μs
t _{EH1}		Duration of Program Operation (\overline{E} contr.)	10		10		μs
t _{WHWH2}		Duration of Erase Operation (\overline{W} contr.)	9.5		9.5		ms
t _{EH2}		Duration of Erase Operation (\overline{E} contr.)	9.5		9.5		ms
t _{WHEH}	t _{CH}	Write Enable High to Chip Enable High	0		0		ns
t _{EHH}		Chip Enable High to Write Enable High	0		0		ns
t _{WHWL}	t _{WPH}	Write Enable High to Write Enable Low	10		20		ns
t _{EHEL}		Chip Enable High to Chip Enable Low	10		20		ns
t _{WHGL}		Write Enable High to Output Enable Low	6		6		μs
t _{EHGL}		Chip Enable High to Output Enable Low	6		6		μs
t _{AVQV}	t _{ACC}	Address Valid to data Output		70		90	ns
t _{ELQX} ⁽¹⁾	t _{LZ}	Chip Enable Low to Output Transition	0		0		ns
t _{ELQV}	t _{CE}	Chip Enable Low to Output Valid		70		90	ns
t _{GLQX} ⁽¹⁾	t _{OLZ}	Output Enable Low to Output Transition	0		0		ns
t _{GLQV}	t _{OE}	Output Enable Low to Output Valid		25		30	ns
t _{EHQZ} ⁽¹⁾		Chip Enable High to Output Hi-Z		25		30	ns
t _{GHQZ} ⁽¹⁾	t _{DF}	Output Enable High to Output Hi-Z		25		30	ns
t _{AXQX}	t _{OH}	Address Transition to Output Transition	0		0		ns

Note: 1. Sampled only, not 100% tested

Table 10B. Read/Write Mode AC Characteristics, \overline{W} and \overline{E} Controlled
 ($T_A = 0$ to 70 °C, -40 to 85 °C or -40 to 125 °C)

Symbol	Alt	Parameter	M28F201				Unit
			-120		-150		
			$V_{CC} = 5V \pm 10\%$		$V_{CC} = 5V \pm 10\%$		
			EPROM Interface		EPROM Interface		
Min	Max	Min	Max				
t _{VPHEL}		V _{PP} High to Chip Enable Low	1		1		μs
t _{VPHWL}		V _{PP} High to Write Enable Low	1		1		μs
t _{WHWH3}	t _{WC}	Write Cycle Time (\overline{W} controlled)	120		150		ns
t _{EH3}	t _{WC}	Write Cycle Time (\overline{E} controlled)	120		150		ns
t _{AVWL}	t _{AS}	Address Valid to Write Enable Low	0		0		ns
t _{AVEL}		Address Valid to Chip Enable Low	0		0		ns
t _{WLAX}	t _{AH}	Write Enable Low to Address Transition	50		50		ns
t _{ELAX}		Chip Enable Low to Address Transition	60		80		ns
t _{ELWL}	t _{CS}	Chip Enable Low to Write Enable Low	0		0		ns
t _{WLEL}		Write Enable Low to Chip Enable Low	0		0		ns
t _{GHWL}		Output Enable High to Write Enable Low	0		0		μs
t _{GHEL}		Output Enable High to Chip Enable Low	0		0		μs
t _{DVWH}	t _{DS}	Input Valid to Write Enable High	50		50		ns
t _{DVEH}		Input Valid to Chip Enable High	50		50		ns
t _{WLWH}	t _{WP}	Write Enable Low to Write Enable High (Write Pulse)	50		60		ns
t _{LEH}		Chip Enable Low to Chip Enable High (Write Pulse)	70		80		ns
t _{WHDX}	t _{DH}	Write Enable High to Input Transition	10		10		ns
t _{EHD}		Chip Enable High to Input Transition	10		10		ns
t _{WHWH1}		Duration of Program Operation (\overline{W} contr.)	10		10		μs
t _{EH1}		Duration of Program Operation (\overline{E} contr.)	10		10		μs
t _{WHWH2}		Duration of Erase Operation (\overline{W} contr.)	9.5		9.5		ms
t _{EH2}		Duration of Erase Operation (\overline{E} contr.)	9.5		9.5		ms
t _{WHEH}	t _{CH}	Write Enable High to Chip Enable High	0		0		ns
t _{EHH}		Chip Enable High to Write Enable High	0		0		ns
t _{WHWL}	t _{WPH}	Write Enable High to Write Enable Low	20		20		ns
t _{EHEL}		Chip Enable High to Chip Enable Low	20		20		ns
t _{WHGL}		Write Enable High to Output Enable Low	6		6		μs
t _{EHGL}		Chip Enable High to Output Enable Low	6		6		μs
t _{AVQV}	t _{ACC}	Address Valid to data Output		120		150	ns
t _{ELQX} ⁽¹⁾	t _{LZ}	Chip Enable Low to Output Transition	0		0		ns
t _{ELQV}	t _{CE}	Chip Enable Low to Output Valid		120		150	ns
t _{GLQX} ⁽¹⁾	t _{OLZ}	Output Enable Low to Output Transition	0		0		ns
t _{GLQV}	t _{OE}	Output Enable Low to Output Valid		35		40	ns
t _{EHQZ} ⁽¹⁾		Chip Enable High to Output Hi-Z		30		35	ns
t _{GHQZ} ⁽¹⁾	t _{DF}	Output Enable High to Output Hi-Z		30		35	ns
t _{AXQX}	t _{OH}	Address Transition to Output Transition	0		0		ns

Note: 1. Sampled only, not 100% tested



Figure 9. Erase Set-up and Erase Verify Commands Waveforms, \bar{E} Controlled

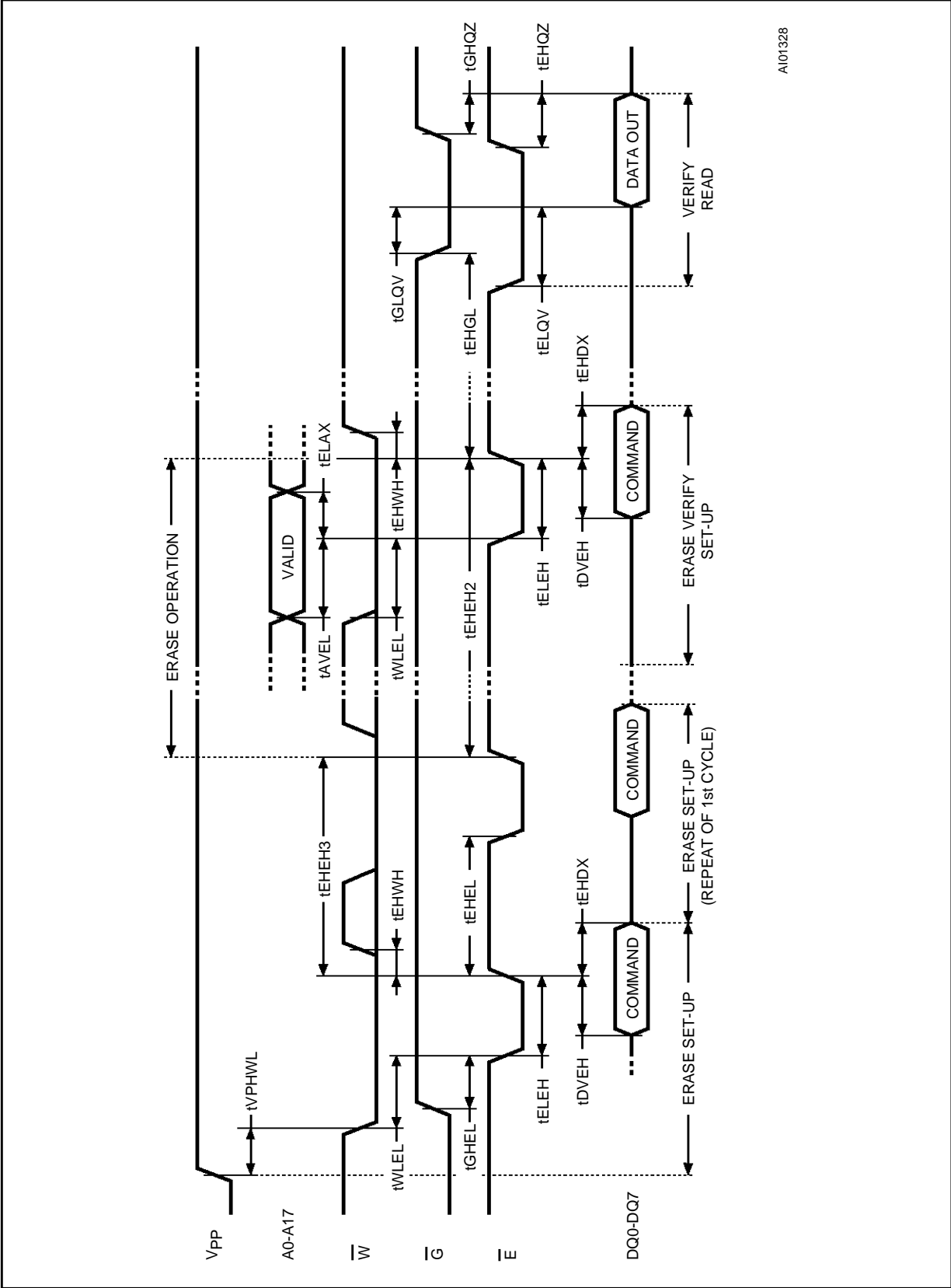

A101328

Figure 12. Erasing Flowchart

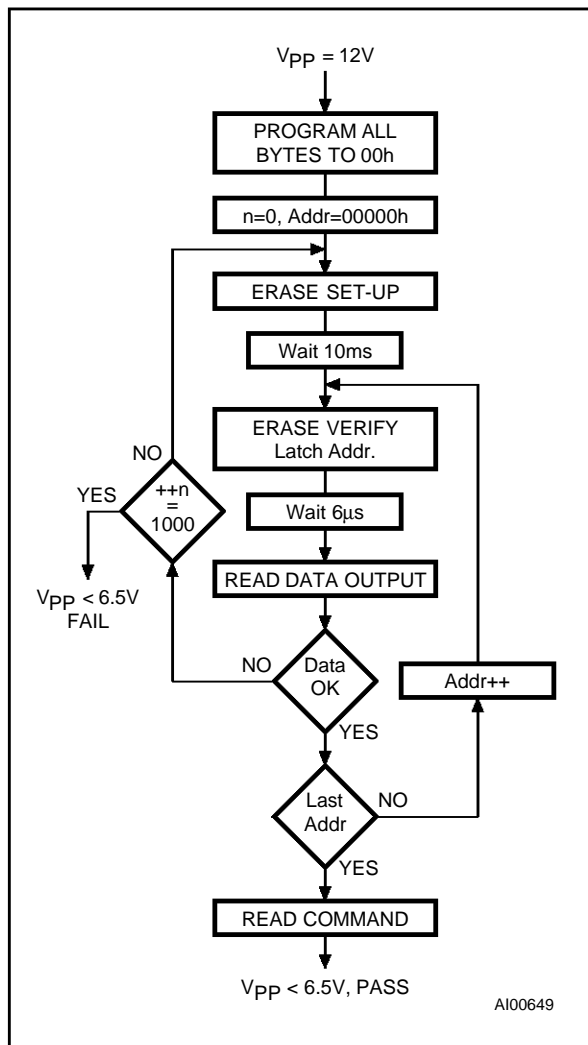
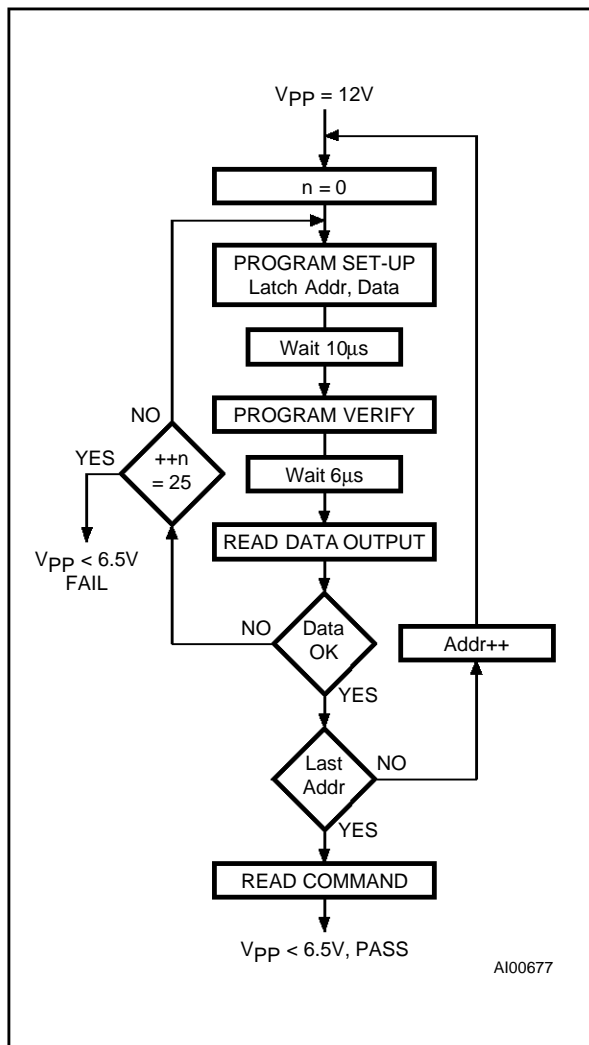

Figure 13. Programming Flowchart



PRESTO F ERASE ALGORITHM

The PRESTO F Erase Algorithm guarantees that the device will be erased in a reliable way. The algorithm first programs all bytes to 00h in order to ensure uniform erasure. The programming follows the PRESTO F Programming Algorithm. Erase is set-up by writing 20h to the command register, the erasure is started by repeating this write cycle. Erase Verify is set-up by writing A0h to the command register together with the address of the byte to be verified. The subsequent read cycle reads the data which is compared to FFh. Erase Verify begins at address 0000h and continues to the last address or until the comparison of the data to FFh fails. If this occurs, the address of the last byte checked is stored and a new Erase operation performed. Erase Verify then continues from the address of the stored location.

PRESTO F PROGRAM ALGORITHM

The PRESTO F Programming Algorithm applies a series of 10µs programming pulses to a byte until a correct verify occurs. Up to 25 programming operations are allowed for one byte. Program is set-up by writing 40h to the command register, the programming is started after the next write cycle which also latches the address and data to be programmed. Program Verify is set-up by writing C0h to the command register, followed by a read cycle and a compare of the data read to the data expected. During Program and Program Verify operations a MARGIN MODE circuit is activated to guarantee that the cell is programmed with a safety margin.



ORDERING INFORMATION SCHEME

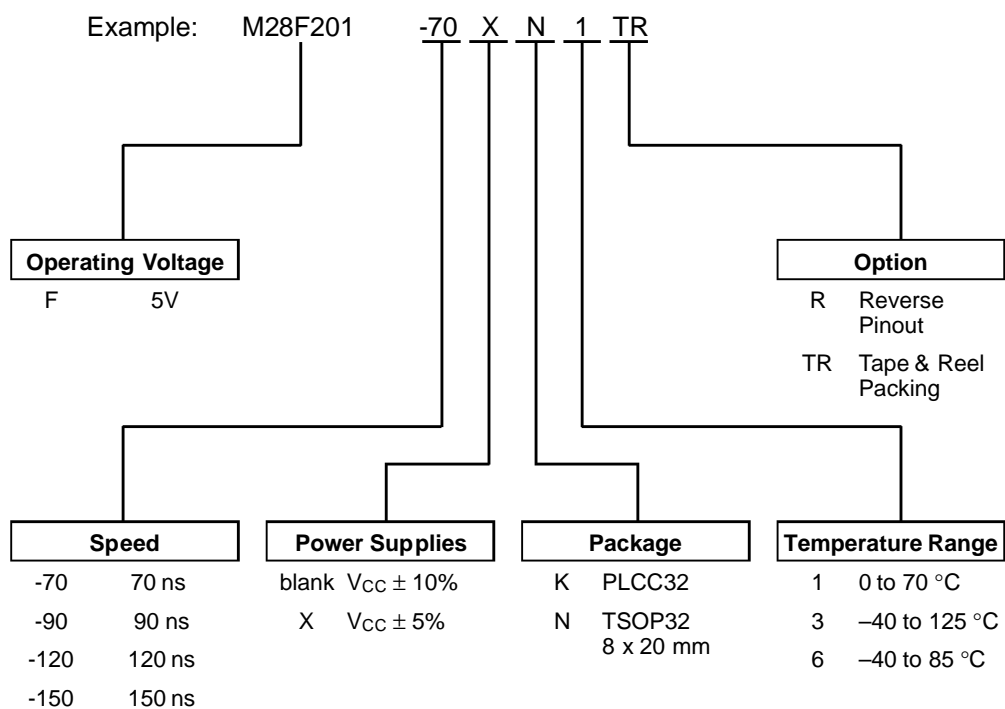

Devices are shipped from the factory with the memory content erased (to FFh).

For a list of available options (Speed, Package, etc...) or for further information on any aspect of this device, please contact the SGS-THOMSON Sales Office nearest to you.

PLCC32 - 32 lead Plastic Leaded Chip Carrier, rectangular

Symb	mm			inches		
	Typ	Min	Max	Typ	Min	Max
A		2.54	3.56		0.100	0.140
A1		1.52	2.41		0.060	0.095
B		0.33	0.53		0.013	0.021
B1		0.66	0.81		0.026	0.032
D		12.32	12.57		0.485	0.495
D1		11.35	11.56		0.447	0.455
D2		9.91	10.92		0.390	0.430
E		14.86	15.11		0.585	0.595
E1		13.89	14.10		0.547	0.555
E2		12.45	13.46		0.490	0.530
e	1.27	-	-	0.050	-	-
N		32			32	
Nd		7			7	
Ne		9			9	
CP			0.10			0.004

PLCC32

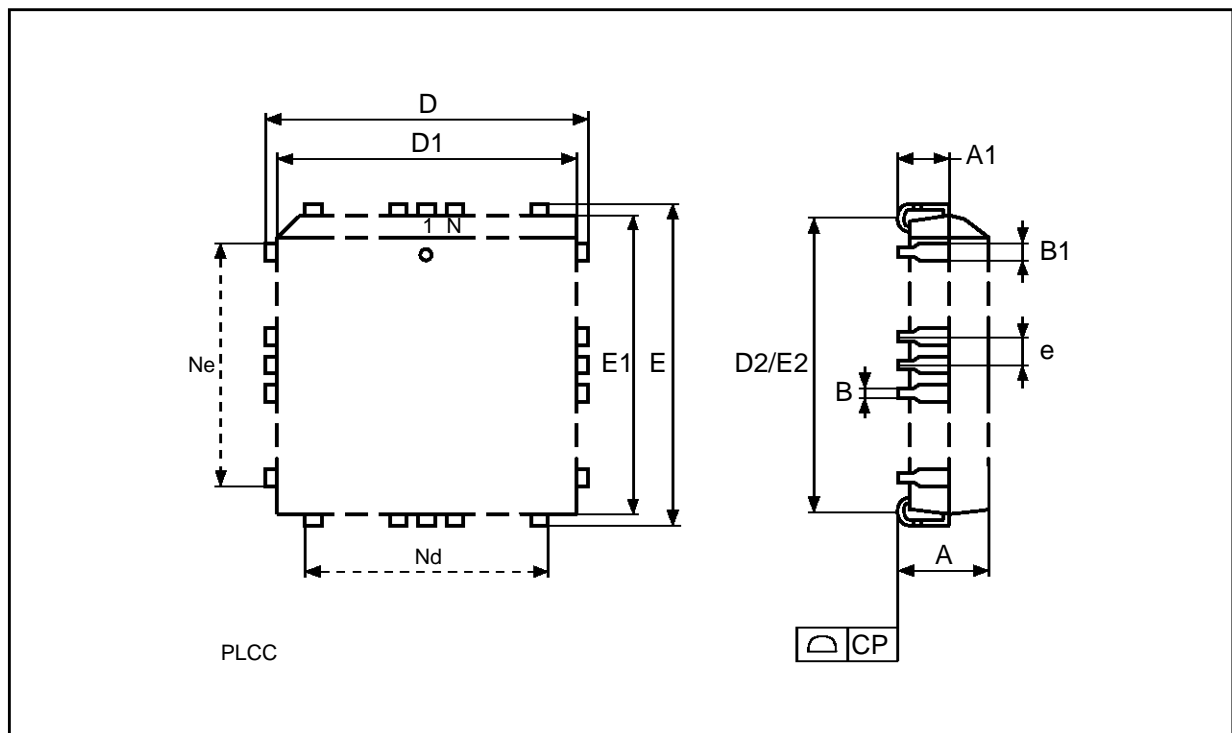

Drawing is not to scale.

TSOP32 Normal Pinout - 32 lead Plastic Thin Small Outline, 8 x 20mm

Symb	mm			inches		
	Typ	Min	Max	Typ	Min	Max
A			1.20			0.047
A1		0.05	0.17		0.002	0.006
A2		0.95	1.50		0.037	0.059
B		0.15	0.27		0.006	0.011
C		0.10	0.21		0.004	0.008
D		19.80	20.20		0.780	0.795
D1		18.30	18.50		0.720	0.728
E		7.90	8.10		0.311	0.319
e	0.50	–	–	0.020	–	–
L		0.50	0.70		0.020	0.028
α		0°	5°		0°	5°
N	32			32		
CP			0.10			0.004

TSOP32

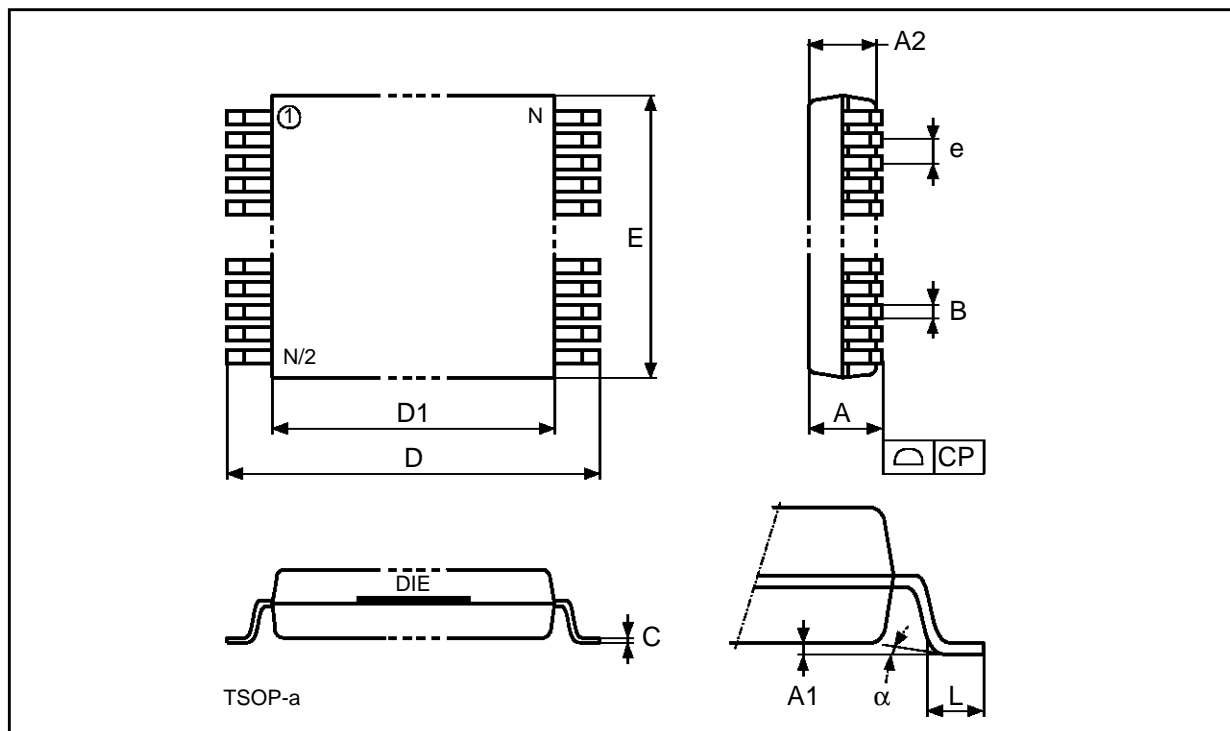

Drawing is not to scale.

TSOP32 Reverse Pinout - 32 lead Plastic Thin Small Outline, 8 x 20mm

Symb	mm			inches		
	Typ	Min	Max	Typ	Min	Max
A			1.20			0.047
A1		0.05	0.17		0.002	0.006
A2		0.95	1.50		0.037	0.059
B		0.15	0.27		0.006	0.011
C		0.10	0.21		0.004	0.008
D		19.80	20.20		0.780	0.795
D1		18.30	18.50		0.720	0.728
E		7.90	8.10		0.311	0.319
e	0.50	-	-	0.020	-	-
L		0.50	0.70		0.020	0.028
α		0°	5°		0°	5°
N	32			32		
CP			0.10			0.004

TSOP32

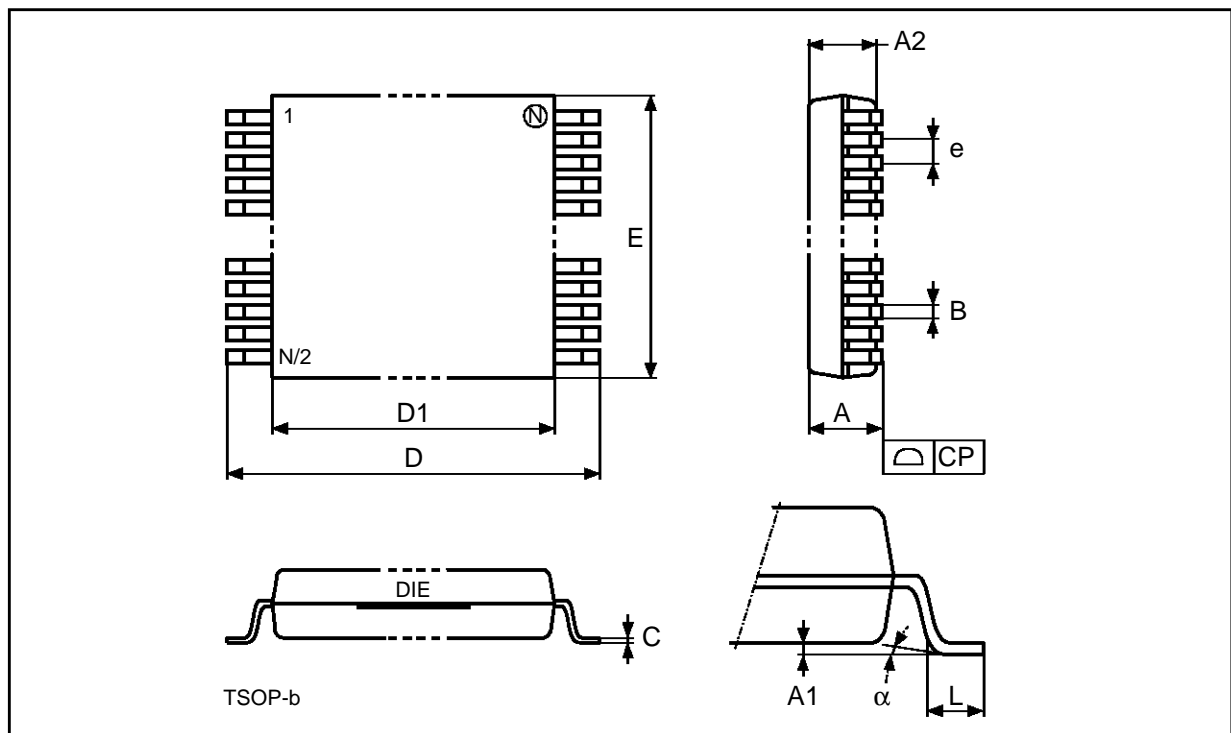

Drawing is not to scale.

Information furnished is believed to be accurate and reliable. However, SGS-THOMSON Microelectronics assumes no responsibility for the consequences of use of such information nor for any infringement of patents or other rights of third parties which may result from its use. No license is granted by implication or otherwise under any patent or patent rights of SGS-THOMSON Microelectronics. Specifications mentioned in this publication are subject to change without notice. This publication supersedes and replaces all information previously supplied. SGS-THOMSON Microelectronics products are not authorized for use as critical components in life support devices or systems without express written approval of SGS-THOMSON Microelectronics.

© 1997 SGS-THOMSON Microelectronics - All Rights Reserved

SGS-THOMSON Microelectronics GROUP OF COMPANIES

Australia - Brazil - Canada - China - France - Germany - Hong Kong - Italy - Japan - Korea - Malaysia - Malta - Morocco - The Netherlands - Singapore - Spain - Sweden - Switzerland - Taiwan - Thailand - United Kingdom - U.S.A.

