

# Bipolar Driver IC

# SI-7200M

## ■ Ratings

(Ta = 25°C)

Type No.	Supply voltage (V)		Output current (A)	Junction temperature (°C)	Operating ambient temperature (°C)	Storage temperature (°C)
	V <sub>CC1</sub>	V <sub>CC2</sub>	I <sub>o</sub>	T <sub>j</sub>	T <sub>op</sub>	T <sub>stg</sub>
SI-7200M	50	10	1.2	+125	-20 to +80	-30 to +100

## ■ Characteristics

Type No.	Supply voltage (V)						*Output current (mA)						Excitation signal				Power down				Trigger pulse						V <sub>CC2</sub> input current (mA)					
	V <sub>CC1</sub>		V <sub>CC2</sub>		I <sub>o</sub>		I <sub>o1</sub>		I <sub>o2</sub> (Power down)		V <sub>IL</sub> (ON)		V <sub>IH</sub> (OFF)		I <sub>L</sub>	V <sub>PD-L</sub> (OFF)		V <sub>PD-H</sub> (ON)		I <sub>PD-L</sub>	I <sub>PD-H</sub>	V <sub>trig</sub>		T <sub>trig</sub>		F <sub>trig</sub>		I <sub>CC2</sub>				
	min	typ	max	min	typ	max	min	max	min	typ	max	min	max	min	max	min	max	min	max	min	max	min	max	min	typ	typ	max	max				
SI-7200M	15	30	40	4.5	5	5.5	200	1000	390	440	490	235	275	315	0	0.5	V <sub>CC2</sub> -0.4	V <sub>CC2</sub> +2	1.6	0	0.4	2	V <sub>CC2</sub>	1	2	3.5	V <sub>CC2</sub>	1.0	2.0	20	25	45

\* I<sub>o1</sub> : Measurement conditions shown in the external connection diagram

I<sub>o2</sub> : Measurement conditions shown in the external connection diagram with pin 9 open

## ■ Block diagram

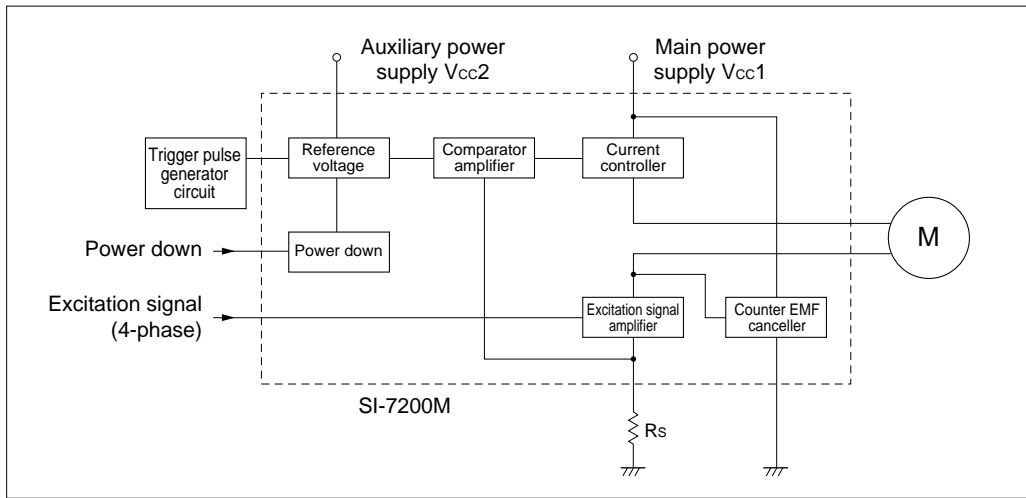

## ■ Equivalent circuit diagram

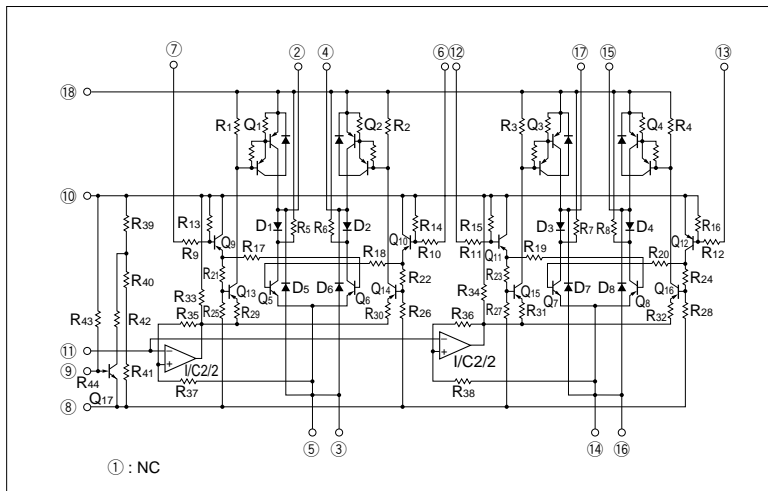

## ■ External dimensions

(Unit: mm)

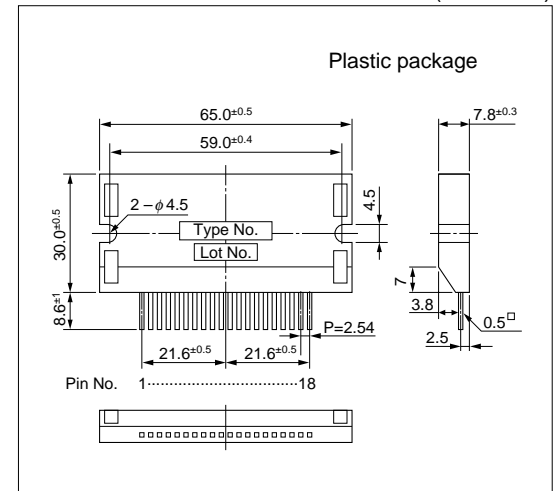



## Application Note

### ■ Determining the output current $I_o$ (motor coil current)

The output current,  $I_o$  is fixed by the following circuit elements:

$R_s$  : Current detection resistor

$V_{CC-2}$  : Auxiliary supply voltage

Based on the specifications of SI-7200M, its output current  $I_o$  can be seen as:

$I_{o1}$  (effective value): 390 to 490mA

To compute  $I_o$  when different values are used for  $R_s$  and  $V_{CC-2}$ , use the approximation formula below or the graph at the right. The maximum ripple value  $I_{OH}$  of the output current waveform is within the  $I_{OH(MIN)} \sim I_{OH(MAX)}$  range shown by the following formulas:

$$I_{OH(max)} \doteq \frac{1}{R_s} (0.247 \times V_{CC-2} - 0.03) \text{ [A]}$$

$$I_{OH(min)} \doteq \frac{1}{R_s} (0.225 \times V_{CC-2} - 0.024) \text{ [A]}$$

To fine-adjust the output current, connect a 20K $\Omega$  variable resistor across pins 8 and 11.

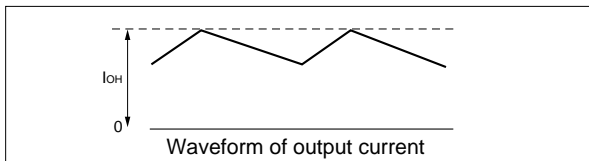

Output current vs. Current detection resistor

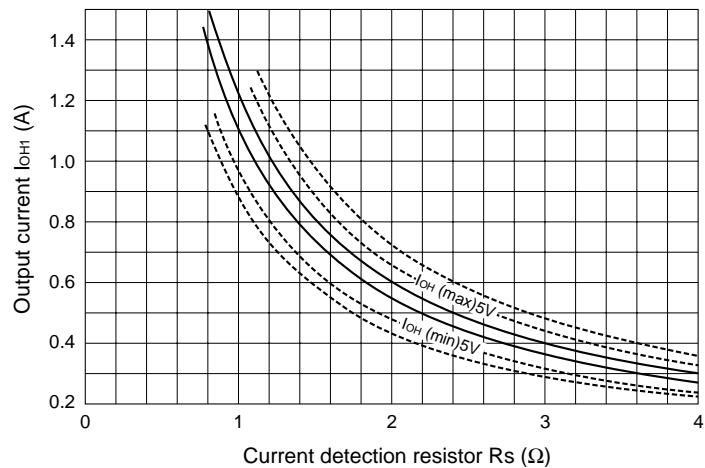

### ■ Power down mode

The SI-7200M can be operated in power down mode. By pulling up pin 9 to high level  $I_o$  can be reduced to 60% of the motor rotation current.

Power down output current vs. Current detection resistor

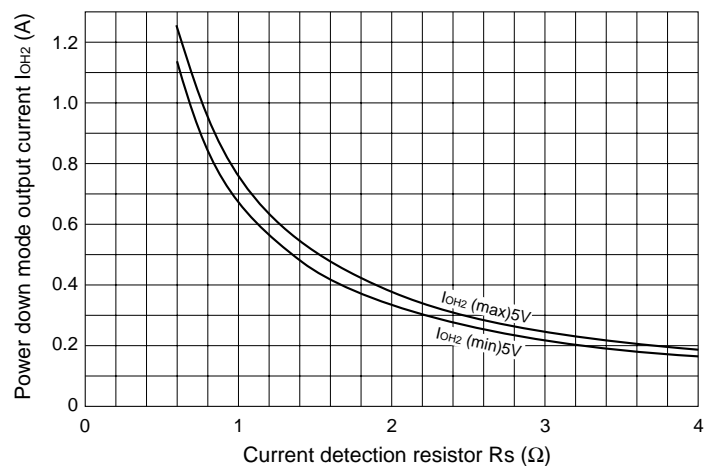

### ■ Operating voltage range

The SI-7200M can be used in applications (low coil resistance  $R_L$  and high supply voltage  $V_{CC}$ ) where SI-7200E and SI-7230E cannot be used.

## Application Note

### Thermal design

Procedures for thermal design of SI-7200M are shown below.

(1) As shown in the figure below, the supply current  $I_{CC}$  and the output current  $I_o$  are measured at the maximum level of the supply voltage  $V_{CC}$ . However, the motor is in holding mode at the 2-phase excitation.

(2) From the above measurements, the internal power dissipation (2-phase) of the hybrid IC can be obtained through the following formula.

$$P_D = V_{CC} \times I_{CC} - 2I_o^2 (R_L + R_s)$$

Where  $R_L$ : Resistance of the motor coil between pins 2 and 4 and pins 15 and 17

Shown in the lower graph is a sample calculation of  $P_D$  vs.  $I_o$ .

(3) The heatsink area corresponding to the ambient temperature can be obtained from the SI-7200M derating curve shown in the right.

(4) Verify that the temperature of the aluminum base plate of the hybrid IC or adjacent heatsink is below  $85^\circ\text{C}$  (equivalent to max. ambient temperature) when operating under actual load conditions.

\* For details on thermal design, refer to the technical data book

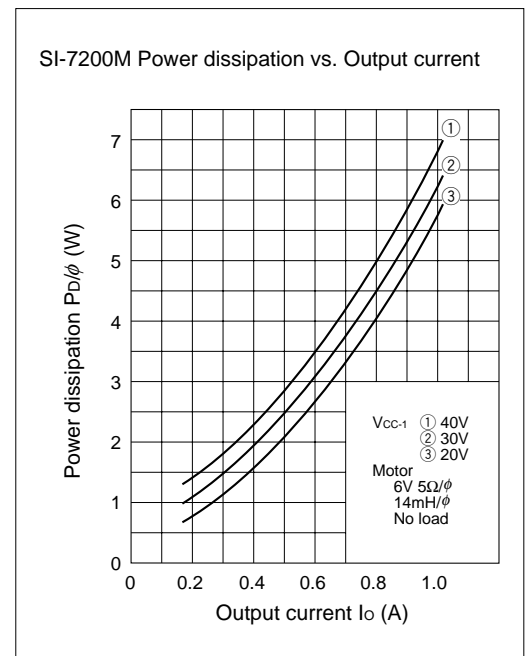
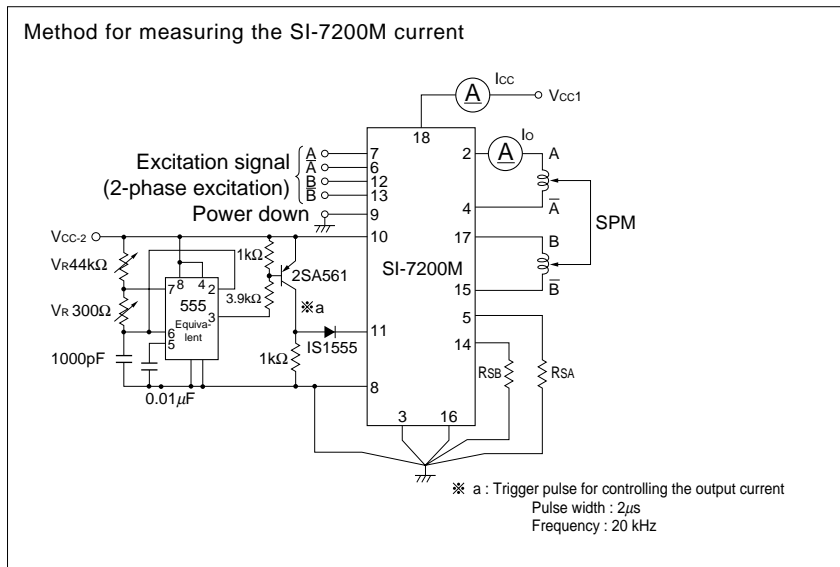
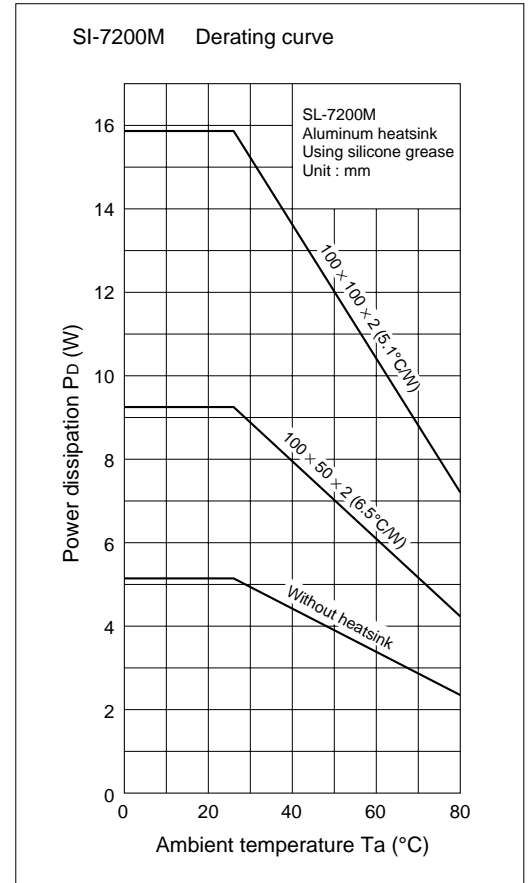

# SI-7200M, SI-7230M, SI-7115B, SI-7300A, SI-7330A, SI-7500A and SI-7502

## Handling Precautions

(Note: The SI-7502 is applicable for item (2) only.)

For details, refer to the relevant product specifications.

### (1) Tightening torque:

The torque to be applied in tightening screws when mounting the IC on a heatsink should be below 49N•m.

### (2) Solvent:

Do not use the following solvents:

Substances that dissolve the package	Chlorine-based solvents : Trichloroethylene, Trichloroethane, etc. Aromatic hydrogen compounds: Benzene, Toluene, Xylene, etc. Ketone and Acetone group solvents
Substances that weaken the package	Gasoline, Benzine and Kerosene

### (3) Silicone grease:

The silicone grease to be used between the aluminum base plate of the hybrid IC and the heatsink should be any of the following:

- G-746 SHINETSU CHEMICAL INDUSTRIES CO., LTD.
- YG6260 TOSHIBA SILICONE CO., LTD.
- SC102 DOW CORNING TORAY SILICONE CO., LTD.

Please pay sufficient attention in selecting silicone grease since oil in some grease may penetrate the product, which will result in an extremely short product life.

## Others

### • Resistance against radiation

Resistance against radiation was not considered in the development of these ICs because it is assumed that they will be used in ordinary environment.