

DATA SHEET

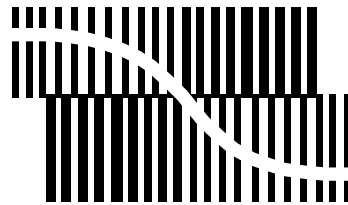

BITSTREAM CONVERSION

UDA1342TS **Audio CODEC**

Preliminary specification
File under Integrated Circuits, IC01

2000 Mar 29

Audio CODEC**UDA1342TS****CONTENTS**

1	FEATURES	9.9	DAC power control
2	APPLICATIONS	9.10	Input oversampling rate
3	GENERAL DESCRIPTION	9.11	DAC polarity
4	QUICK REFERENCE DATA	9.12	DAC mixing position switch
5	ORDERING INFORMATION	9.13	DAC mixer
6	BLOCK DIAGRAM	9.14	Silence detection period
7	PINNING	9.15	Multi purpose output
8	FUNCTIONAL DESCRIPTION	9.16	Mode
8.1	System clock	9.17	Bass boost
8.2	ADC analog front-end	9.18	Treble
8.2.1	Application with 2 V (RMS) input	9.19	Silence detector switch
8.2.2	Double differential mode	9.20	Mute
8.3	Decimation filter (ADC)	9.21	Quick mute mode
8.4	Digital mixer (ADC)	9.22	De-emphasis
8.5	Interpolation filter (DAC)	9.23	ADC input amplifier gain
8.6	Mute	9.24	DAC volume control
8.7	Digital mixer (DAC)	9.25	DAC mixer volume control
8.8	Noise shaper	9.26	ADC mixer gain control
8.9	Filter stream DAC	10	LIMITING VALUES
8.10	Digital interface	11	HANDLING
8.11	Sampling speed	12	QUALITY SPECIFICATION
8.12	Power-on reset	13	THERMAL CHARACTERISTICS
8.13	Control modes	14	DC CHARACTERISTICS
8.14	Static pin mode	15	AC CHARACTERISTICS
8.14.1	System clock setting select	16	TIMING
8.14.2	Digital interface format select	17	APPLICATION INFORMATION
8.14.3	ADC input channel select	18	PACKAGE OUTLINE
8.15	L3-bus interface	19	SOLDERING
8.15.1	Introduction	19.1	Introduction to soldering surface mount packages
8.15.2	Device addressing	19.2	Reflow soldering
8.15.3	Register addressing	19.3	Wave soldering
8.15.4	Data write mode	19.4	Manual soldering
8.15.5	Data read mode	19.5	Suitability of surface mount IC packages for wave and reflow soldering methods
8.16	I ² C-bus interface	20	DATA SHEET STATUS
8.16.1	Addressing	21	DEFINITIONS
8.16.2	Slave address	22	DISCLAIMERS
8.16.3	Register address	23	PURCHASE OF PHILIPS I ² C COMPONENTS
8.16.4	Write cycle		
8.16.5	Read cycle		
9	REGISTER MAPPING		
9.1	Reset		
9.2	Quick mode switch		
9.3	Bypass mixer DC filter		
9.4	DC filter		
9.5	ADC mode		
9.6	ADC polarity		
9.7	System clock frequency		
9.8	Data format		

Audio CODEC

UDA1342TS

1 FEATURES**General**

- 2.7 to 3.6 V power supply
- 5 V tolerant digital inputs
- High pin compatibility with UDA1341TS
- 24 bits data path
- Selectable control via L3-bus interface, I²C-bus interface or static pin control; choice of 2 device addresses in L3-bus and I²C-bus mode
- Supports sample frequencies from 16 to 110 kHz
- Separate power control for ADC and DAC
- ADC and Programmable Gain Amplifiers (PGA) plus integrated high-pass filter to cancel DC offset
- Integrated digital filter plus DAC
- Digital silence detection
- No analog post filtering required for DAC
- Slave mode only applications
- Easy application.

Multiple format data interface

- I²S-bus, MSB-justified and LSB-justified format compatible
- 1f_s to 4f_s input and 1f_s output format data rate.

DAC digital sound processing

- Separate digital logarithmic volume control for left and right channels in L3-bus mode or I²C-bus mode
- Digital tone control, bass boost and treble in L3-bus mode or I²C-bus mode
- Digital de-emphasis for sample frequencies of 32, 44.1, 48 and 96 kHz in L3-bus mode or I²C-bus mode
- Soft or quick mute in L3-bus mode or I²C-bus mode
- Output signal polarity control in L3-bus mode or I²C-bus mode
- Digital mixer for ADC output signal and digital serial input signal.

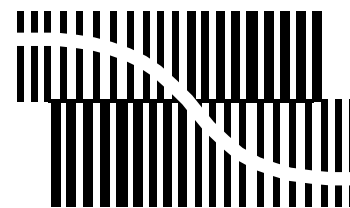

BITSTREAM CONVERSION

Advanced audio configuration

- 4 channel (2 × stereo) single-ended inputs with programmable gain amplifiers and 2 channel (1 × stereo) single-ended outputs configuration
- Output signal polarity control in L3-bus mode or I²C-bus mode
- High linearity, wide dynamic range, low distortion
- Double differential input configuration for enhanced ADC sound quality.

2 APPLICATIONS

- Eminently suitable for MiniDisc (MD) home and portable applications.

3 GENERAL DESCRIPTION

The UDA1342TS is a single-chip 4 channel analog-to-digital converter and 2 channel digital-to-analog converter with signal processing features employing bitstream conversion techniques. The low power consumption and low voltage requirements make the device eminently suitable for use in low-voltage low-power portable digital audio equipment which incorporates recording and playback functions.

The UDA1342TS supports the I²S-bus data format with word lengths of up to 24 bits, the MSB-justified data format with word lengths of up to 24 bits and the LSB-justified serial data format with word lengths of 16, 20 and 24 bits. The device also supports a combination of the MSB-justified output format and the LSB-justified input format.

The UDA1342TS has special sound processing features in the playback mode such as de-emphasis, volume, mute, bass boost and treble, which can be controlled by the microcontroller via the L3-bus or I²C-bus interface.

Audio CODEC

UDA1342TS

4 QUICK REFERENCE DATA

SYMBOL	PARAMETER	CONDITIONS	MIN.	TYP.	MAX.	UNIT
Supplies						
$V_{DDA(ADC)}$	ADC analog supply voltage		2.7	3.0	3.6	V
$V_{DDA(DAC)}$	DAC analog supply voltage		2.7	3.0	3.6	V
V_{DDD}	digital supply voltage		2.7	3.0	3.6	V
$I_{DDA(ADC)}$	ADC analog supply current	1 ADC + 1 PGA enabled	–	10.0	–	mA
		2 ADCs + 2 PGAs enabled	–	20.0	–	mA
		all ADCs + all PGAs power-down	–	200	–	μ A
$I_{DDA(DAC)}$	DAC analog supply current	operating	–	6.0	–	mA
		DAC power-down	–	250	–	μ A
I_{DDD}	digital supply current	operating	–	9.0	–	mA
		ADC power-down	–	4.5	–	mA
		DAC power-down	–	5.5	–	mA
T_{amb}	ambient temperature		–40	–	+85	$^{\circ}$ C
Analog-to-digital convertor						
$V_{i(rms)}$	input voltage (RMS value)	at 0 dB (FS) digital output	–	0.9	–	V
$(THD+N)/S_{48}$	total harmonic distortion-plus-noise to signal ratio at $f_s = 48$ kHz	normal mode	–	–	–	
		at –1 dB	–	–90	–	dB
		at –60 dB; A-weighted	–	–40	–	dB
		double differential	–	–	–	
		at –1 dB	–	–93	–	dB
		at –60 dB; A-weighted	–	–41	–	dB
$(THD+N)/S_{96}$	total harmonic distortion-plus-noise to signal ratio at $f_s = 96$ kHz	normal mode	–	–	–	
		at –1 dB	–	–84	–	dB
		at –60 dB; A-weighted	–	–40	–	dB
S/N_{48}	signal-to-noise ratio at $f_s = 48$ kHz	normal mode; $V_i = 0$ V; A-weighted	–	100	–	dB
		double differential mode; $V_i = 0$ V; A-weighted	–	101	–	dB
S/N_{96}	signal-to-noise ratio at $f_s = 96$ kHz	normal mode; $V_i = 0$ V; A-weighted	–	99	–	dB
α_{cs}	channel separation		–	100	–	dB

Audio CODEC

UDA1342TS

SYMBOL	PARAMETER	CONDITIONS	MIN.	TYP.	MAX.	UNIT
Digital-to-analog convertor						
$V_{o(rms)}$	output voltage (RMS value)	at 0 dB (FS) digital input; note 1	–	0.9	–	V
$(THD+N)/S_{48}$	total harmonic distortion-plus-noise to signal ratio at $f_s = 48$ kHz	at 0 dB	–	–90	–	dB
		at –60 dB; A-weighted	–	–40	–	dB
$(THD+N)/S_{96}$	total harmonic distortion-plus-noise to signal ratio at $f_s = 96$ kHz	at 0 dB	–	–83	–	dB
		at –60 dB; A-weighted	–	–39	–	dB
S/N_{48}	signal-to-noise ratio at $f_s = 48$ kHz	code = 0; A-weighted	–	100	–	dB
S/N_{96}	signal-to-noise ratio at $f_s = 96$ kHz	code = 0; A-weighted	–	99	–	dB
α_{CS}	channel separation		–	100	–	dB

Note

1. The output voltage of the DAC is proportionally to the DAC power supply voltage.

5 ORDERING INFORMATION

TYPE NUMBER	PACKAGE		
	NAME	DESCRIPTION	VERSION
UDA1342TS	SSOP28	plastic shrink small outline package; 28 leads; body width 5.3 mm	SOT341-1

Audio CODEC

UDA1342TS

6 BLOCK DIAGRAM

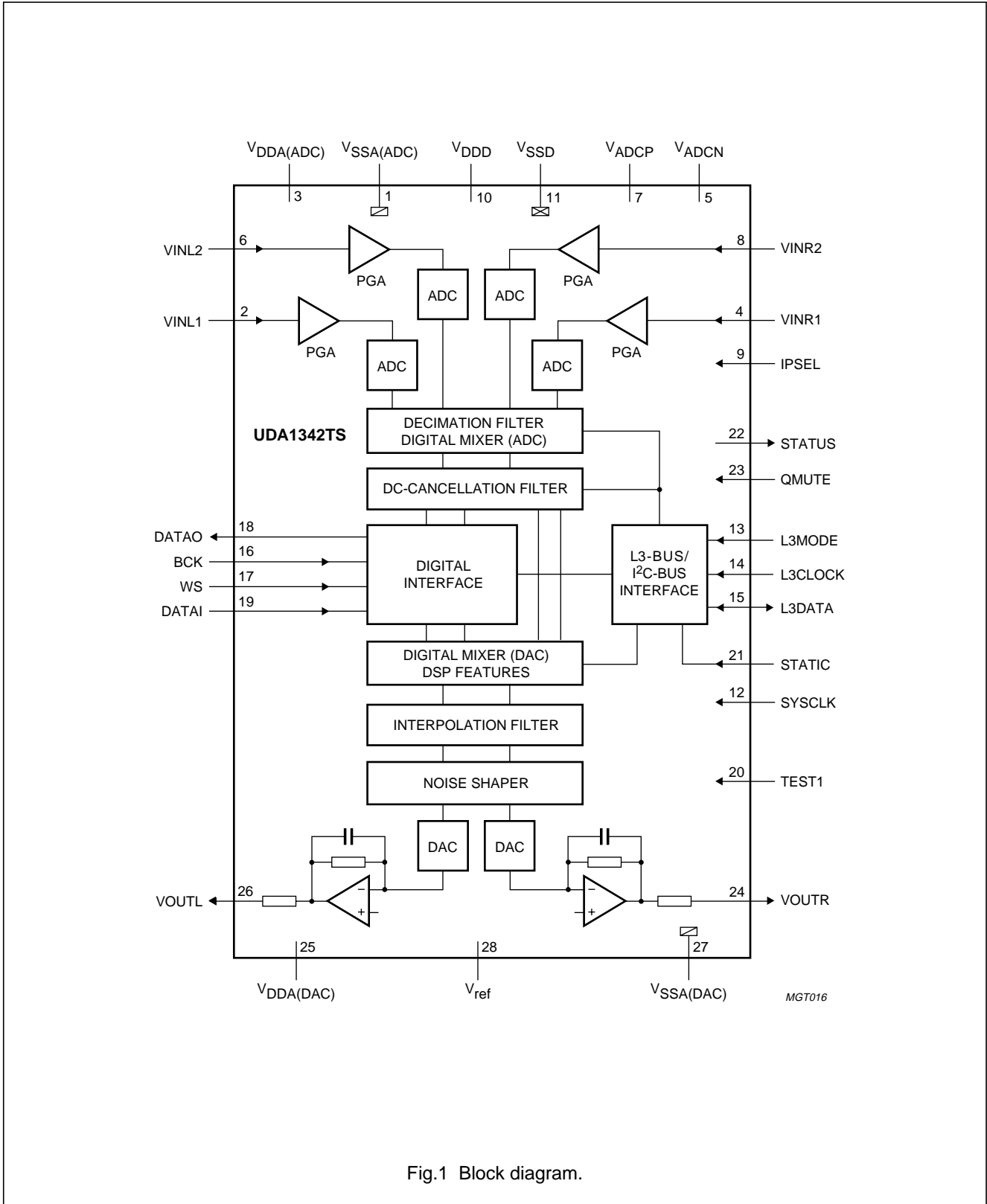

Fig.1 Block diagram.

Audio CODEC

UDA1342TS

7 PINNING

SYMBOL	PIN	TYPE	DESCRIPTION
V _{SSA(ADC)}	1	analog ground pad	ADC analog ground
VINL1	2	analog input pad	ADC input left 1
V _{DDA(ADC)}	3	analog supply pad	ADC analog supply voltage
VINR1	4	analog input pad	ADC input right 1
V _{ADCN}	5	analog pad	ADC reference voltage N
VINL2	6	analog input pad	ADC input left 2
V _{ADCP}	7	analog pad	ADC reference voltage P
VINR2	8	analog input pad	ADC input right 2
IPSEL	9	5 V tolerant digital input pad	channel select input: input left 1 and right 1 or input left 2 and right 2
V _{DDD}	10	digital supply pad	digital supply voltage
V _{SSD}	11	digital ground pad	digital ground
SYCLK	12	5 V tolerant digital input pad	system clock input: 256f _s , 384f _s , 512f _s or 768f _s
L3MODE	13	5 V tolerant digital input pad	L3-bus mode input or mode selection input
L3CLOCK	14	5 V tolerant digital input pad	L3-bus/I ² C-bus clock input or clock selection input
L3DATA	15	5 V tolerant open drain input/output	L3-bus/I ² C-bus data input/output or format selection input
BCK	16	5 V tolerant digital input pad	bit clock input
WS	17	5 V tolerant digital input pad	word select input
DATAO	18	5 V tolerant 2 mA slew rate controlled digital output	data output
DATAI	19	5 V tolerant digital input pad	data input
TEST1	20	5 V tolerant digital input pad	test control input; to be connected to ground
STATIC	21	5 V tolerant digital input pad	mode selection input: static pin control or L3-bus/I ² C-bus control
STATUS	22	5 V tolerant 2 mA slew rate controlled digital output	general purpose output
QMUTE	23	5 V tolerant digital input pad	quick mute input
VOUTR	24	analog output pad	DAC output right
V _{DDA(DAC)}	25	analog supply pad	DAC analog supply voltage
VOUTL	26	analog output pad	DAC output left
V _{SSA(DAC)}	27	analog ground pad	DAC analog ground
V _{ref}	28	analog pad	reference voltage for ADC and DAC

Audio CODEC

UDA1342TS

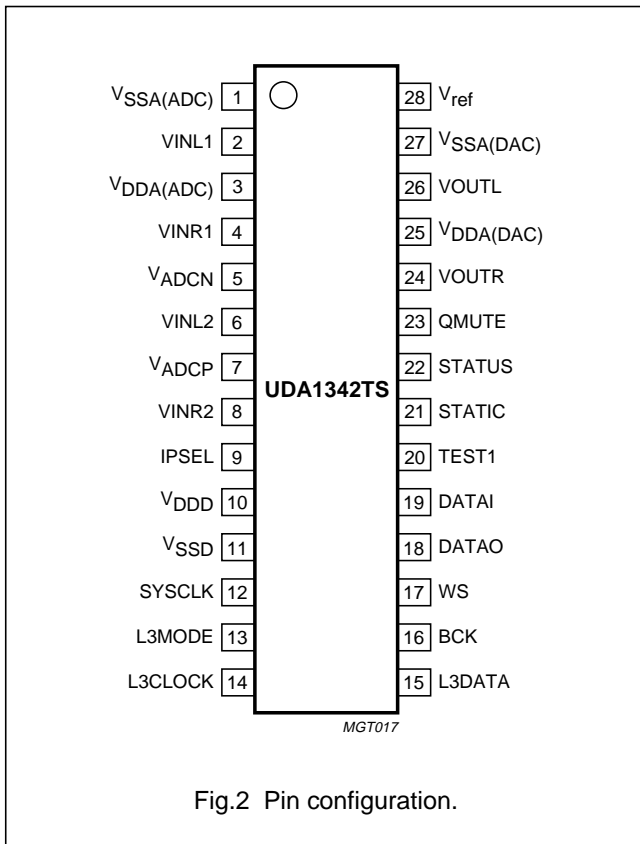

8.2 ADC analog front-end

The analog front-end of the UDA1342TS consists of two stereo ADCs with a programmable gain stage (gain from 0 to 24 dB with 3 dB steps) which can be controlled via the L3-bus/I²C-bus interface.

8.2.1 APPLICATION WITH 2 V (RMS) INPUT

In applications in which a 2 V (RMS) input signal is used, a 15 kΩ resistor must be used in series with the input of the ADC (see Fig.3). This forms a voltage divider together with the internal ADC resistor and ensures that only 1 V (RMS) maximum is input to the IC. Using this application for a 2 V (RMS) input signal, the gain switch must be set to 0 dB. When a 1 V (RMS) input signal is input to the ADC in the same application, the gain switch must be set to 6 dB.

An overview of the maximum input voltages allowed against the presence of an external resistor and the setting of the gain switch is given in Table 1.

Table 1 Application modes using input gain stage

RESISTOR (15 kΩ)	PGA GAIN	MAXIMUM INPUT VOLTAGE
Present	0 dB	2 V (RMS)
Present	6 dB	1 V (RMS)
Absent	0 dB	1 V (RMS)
Absent	6 dB	0.5 V (RMS)

8 FUNCTIONAL DESCRIPTION

8.1 System clock

The UDA1342TS operates in slave mode only, this means that in all applications the system must provide the system clock. The system clock frequency is selectable and depends on the mode of operation:

- L3-bus/I²C-bus mode: 256f_s, 384f_s, 512f_s or 768f_s
- Static pin mode: 256f_s or 384f_s.

The system clock must be locked in frequency to the digital interface signals.

Remarks:

- The bit clock frequency f_{BCK} can be up to 128f_s, or in other words the bit clock frequency is 128 times the word select frequency f_{WS} or less: f_{BCK} ≤ 128f_{WS}
- The WS edge MUST fall on the negative edge of the BCK signal at all times for proper operation of the digital interface
- The UDA1342TS operates with sample frequencies from 16 to 110 kHz, however for a system clock of 768f_s the sampling frequency must be limited to 55 kHz.

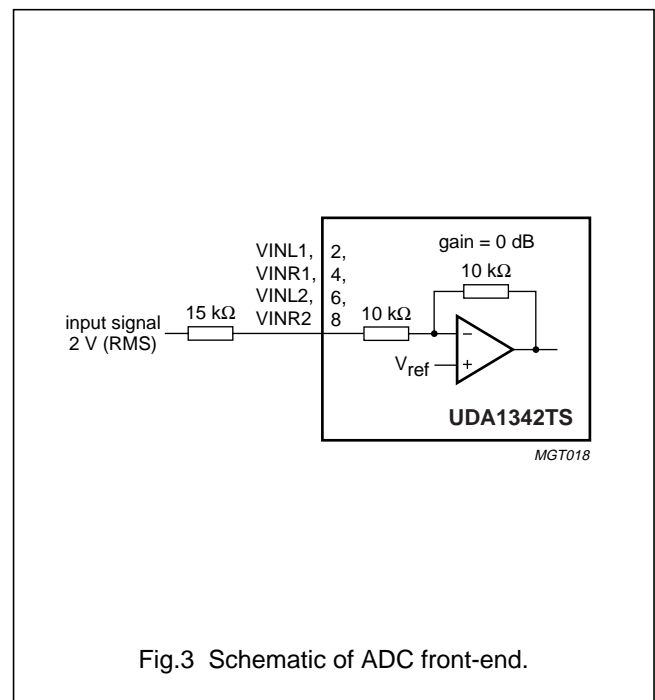

Fig.3 Schematic of ADC front-end.

Audio CODEC

UDA1342TS

8.2.2 DOUBLE DIFFERENTIAL MODE

Since the UDA1342TS is equipped with two stereo ADCs, these two pairs of stereo ADCs can be used to convert a single stereo signal to a signal with a higher performance by using the ADCs in the double differential mode.

This mode and the input signals, being channel 1 or 2 as input to the double differential configuration, can be selected via the L3-bus/I²C-bus interface.

8.3 Decimation filter (ADC)

The decimation from 64f_s to 1f_s is performed in two stages.

The first stage realizes a $\left(\frac{\sin x}{x}\right)^4$ characteristic with a

decimation factor of 8. The second stage consists of three half-band filters, each decimating by a factor of 2. The filter characteristics are shown in Table 2.

Table 2 Decimation filter characteristics

ITEM	CONDITION	VALUE (dB)
Pass-band ripple	0 to 0.45f _s	±0.01
Pass-band droop	0.45f _s	-0.2
Stop band	>0.55f _s	-70
Dynamic range	0 to 0.45f _s	>135

8.4 Digital mixer (ADC)

The two stereo ADC outputs are mixed with gain coefficients from +24 to -60 dB to be set via the microcontroller interface.

In front of the mixer there is a DC filter. In order to prevent clipping, it is needed to filter out the DC component before mixing or amplifying the signals.

The mixing function can be enabled via the microcontroller interface.

8.5 Interpolation filter (DAC)

The digital interpolation filter interpolates from 1f_s to 64f_s by means of a cascade of FIR filters. The filter characteristics are shown in Table 3.

Table 3 Interpolation filter characteristics

ITEM	CONDITION	VALUE (dB)
Pass-band ripple	0 to 0.45f _s	±0.025
Stop band	>0.55f _s	-60
Dynamic range	0 to 0.45f _s	>135

8.6 Mute

Muting the DAC will result in a cosine roll-off soft mute, using 32 × 32 = 1024 samples in the normal mode: this results in 24 ms at f_s = 44.1 kHz. The cosine roll-off curve is illustrated in Fig.4.

This cosine roll-off functions are implemented in the DAC data path before the digital mixer and before the master mute (see Fig.5).

In the L3-bus and I²C-bus mode, the setting of the master mute can be overruled always by pin QMUTE. This quick mute uses the same cosine roll-off, but now for only 32 samples: this is 750 μs at f_s = 44.1 kHz.

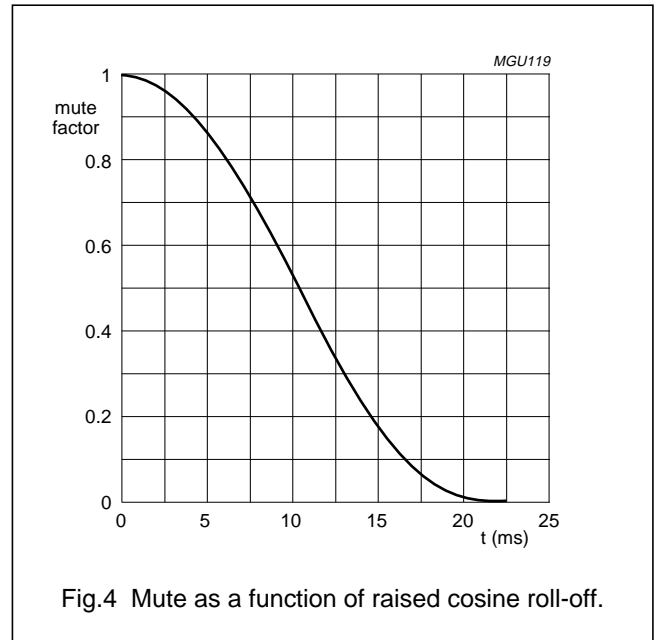

Fig.4 Mute as a function of raised cosine roll-off.

8.7 Digital mixer (DAC)

The ADC output signal and the digital interface input signal can be mixed without an external DSP (see Fig.5).

This mixer can be controlled via the microcontroller interface.

In order to prevent clipping when mixing two 0 dB signals, the signals are attenuated digitally by -6 dB before mixing. After mixing the signal is gained by 6 dB after the master volume. This way clipping at the digital mixer is prevented. After the 6 dB gain, the signals can clip again, but this clipping can be removed by decreasing the master volume.

Audio CODEC

UDA1342TS

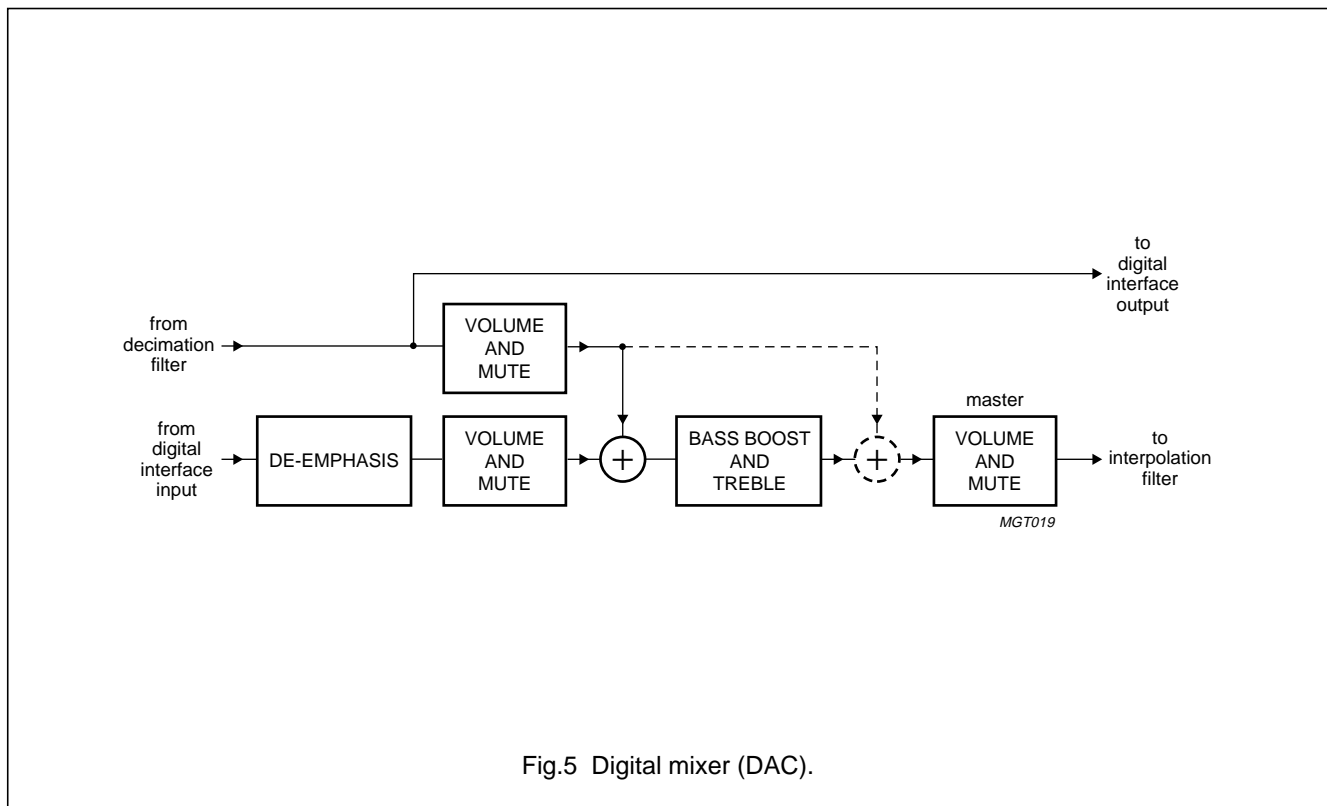

Fig.5 Digital mixer (DAC).

8.8 Noise shaper

The 5th-order noise shaper operates at $64f_s$. It shifts in-band quantization noise to frequencies well above the audio band. This noise shaping technique enables high signal-to-noise ratios to be achieved. The noise shaper output is converted into an analog signal using a Filter Stream Digital-to-Analog Converter (FSDAC).

8.9 Filter stream DAC

The FSDAC is a semi-digital reconstruction filter that converts the 1-bit data stream of the noise shaper to an analog output voltage. The filter coefficients are implemented as current sources and are summed at virtual ground of the output operational amplifier. In this way very high signal-to-noise performance and low clock jitter sensitivity is achieved. A post-filter is not needed due to the inherent filter function of the DAC. On-board amplifiers convert the FSDAC output current to an output voltage signal capable of driving a line output.

The output voltage of the FSDAC is proportionally to the power supply voltage.

8.10 Digital interface

The UDA1342TS supports the following data input/output formats for the various modes (see Fig.6).

L3-bus and I²C-bus mode:

- I²S-bus format with data word length of up to 24 bits
- MSB-justified serial format with data word length of up to 24 bits
- LSB-justified serial format with data word lengths of 16, 20 or 24 bits
- MSB-justified data output and LSB-justified 16, 20 and 24 bits data input.

Static pin mode:

- I²S-bus format with data word length of up to 24 bits
- MSB-justified data output and LSB-justified 16, 20 and 24 bits data input.

Audio CODEC

UDA1342TS

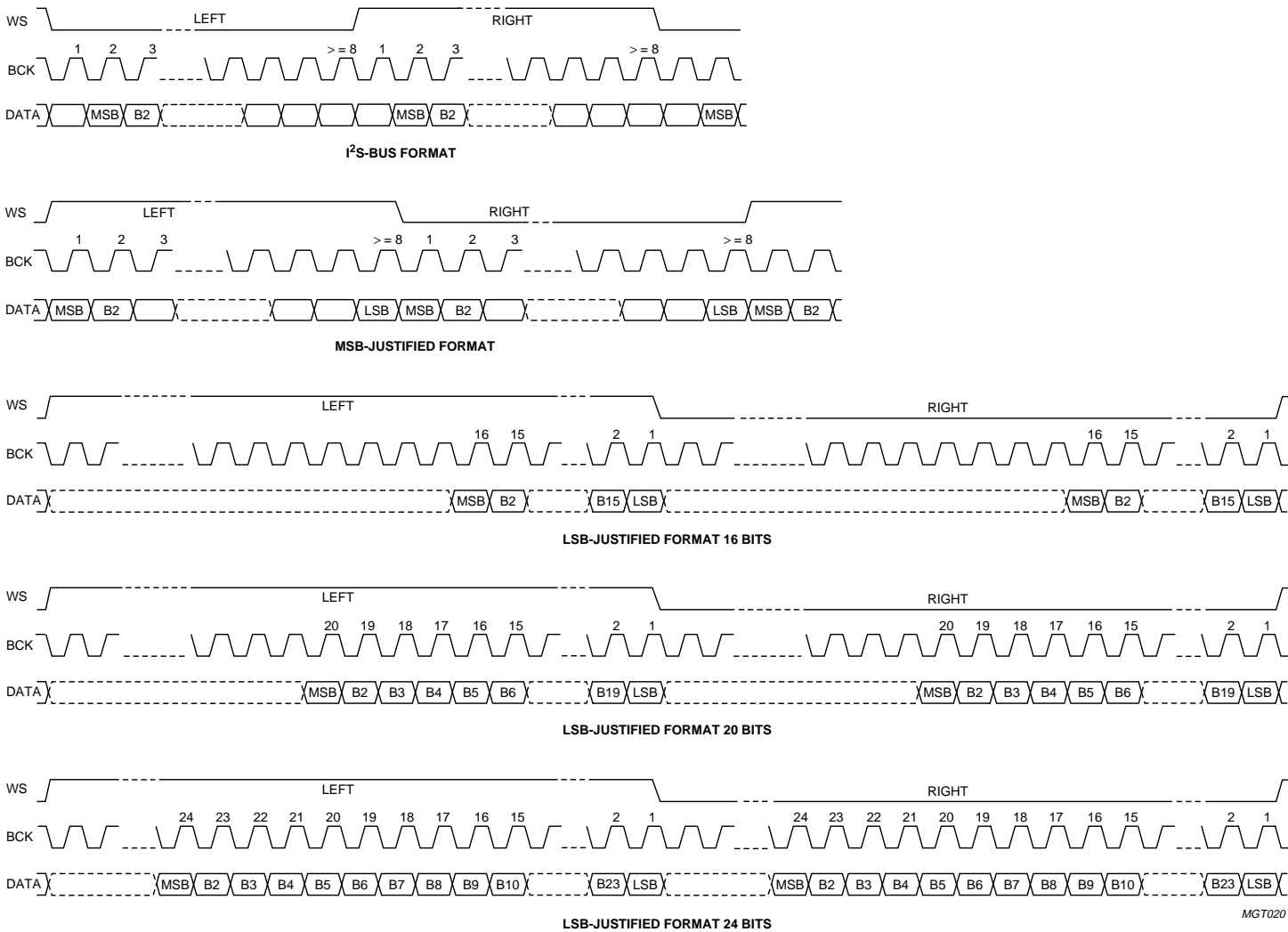

MGT020

Fig.6 Serial interface input/output formats.

Audio CODEC

UDA1342TS

8.11 Sampling speed

The UDA1342TS operates with sample frequencies from 16 to 110 kHz. This range holds for the CODEC as a whole. The DAC part can be configured in the L3-bus and I²C-bus mode to accept 2 times and even 4 times the data speed (e.g. f_s is 96 or 192 kHz), but in these modes not all of the features can be used.

Important: in the double speed mode an input signal of 0 dB is allowed, but in the quad speed mode the input signal must be limited to -6 dB to prevent the system from clipping.

Some examples of the input oversampling rate settings are shown in Table 4.

Table 4 Examples of the input oversampling rate settings

SYSTEM CLOCK	SYSTEM CLOCK FREQUENCY SETTING	SAMPLING FREQUENCY (kHz)	INPUT OVER-SAMPLING RATE	FEATURES SUPPORTED	
12.288 MHz (256 × 48 kHz)	256f _s	48	single speed	all	
		96	double speed	only master volume and mute	
		192	quad speed	no features	
22.5792 MHz (512 × 44.1 kHz)	512f _s	44.1	single speed	all	
		256f _s	88.2	single speed	all
			176.4	double speed	only master volume and mute
33.8688 MHz (768 × 44.1 kHz)	768f _s	44.1	single speed	all	
		384f _s	88.2	single speed	all
			176.4	double speed	only master volume and mute

8.12 Power-on reset

The UDA1342TS has an internal Power-on reset circuit (see Fig.7) which resets the test control block. All the digital sound processing features and the system controlling features are set to their default setting in the L3-bus and I²C-bus mode.

The reset time (see Fig.8) is determined by an external capacitor which is connected between pin V_{ref} and ground. The reset time should be at least 1 μs for V_{ref} < 1.25 V. When V_{DDA(DAC)} is switched off, the device will be reset again for V_{ref} < 0.75 V.

During the reset time the system clock should be running.

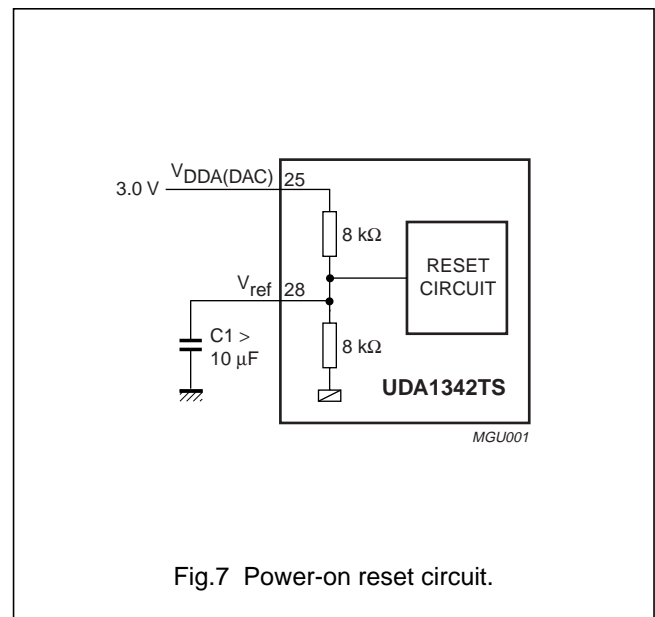

Fig.7 Power-on reset circuit.

Audio CODEC

UDA1342TS

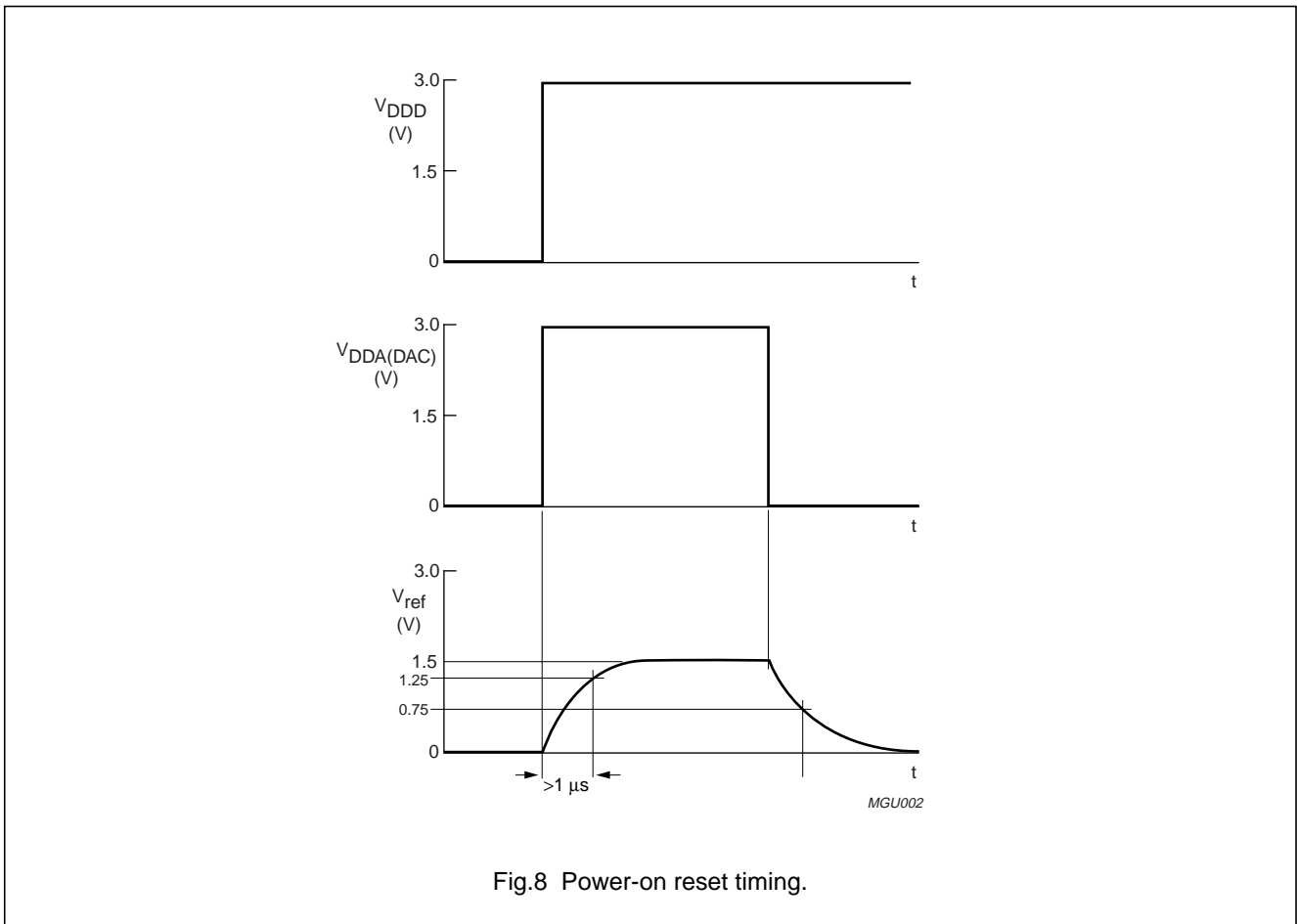

Fig.8 Power-on reset timing.

8.13 Control modes

The control mode can be set with pin STATIC and pin L3MODE:

- Static pin mode
- I²C-bus mode
- L3-bus mode.

Table 5 Mode selection

PIN STATIC	PIN L3MODE	SELECTION
LOW	–	L3-bus mode
HIGH	LOW	I ² C-bus mode
HIGH	HIGH	static pin mode

The pin functions in the various modes are summarized in Table 6.

Table 6 Pin function in the selected mode

PIN NAME	FUNCTION		
	L3-BUS MODE	I ² C-BUS MODE	STATIC PIN MODE
L3CLOCK	L3CLOCK	SCL	clock select
L3MODE	L3MODE	LOW level	HIGH level
L3DATA	L3DATA	SDA	format select
QMUTE	QMUTE	QMUTE	format select
IPSEL	A0	A0	channel select

All features in the L3-bus and I²C-bus mode are explained in Sections 8.15 and 8.16.

Audio CODEC

UDA1342TS

8.14 Static pin mode

The controllable features in the static pin mode are:

- System clock frequency
- Data input and output format select
- ADC input channel select.

8.14.1 SYSTEM CLOCK SETTING SELECT

In the static pin mode pin L3CLOCK is used to select the system clock setting.

Table 7 System clock setting

PIN L3CLOCK	SYSTEM CLOCK SETTING
0	$256f_s$
1	$384f_s$

8.14.2 DIGITAL INTERFACE FORMAT SELECT

In the static pin mode the digital interface audio formats can be selected via pins L3DATA and QMUTE. The following interface formats can be selected (see Table 8):

- I²S-bus format with data word length of up to 24 bits
- MSB-justified output format and LSB-justified input format with data word length of 16, 20 or 24 bits.

Table 8 Data format select in static pin mode

PIN L3DATA	PIN QMUTE	INPUT/OUTPUT FORMAT
0	0	I ² S
0	1	LSB-justified 16 bits input and MSB-justified output
1	0	LSB-justified 20 bits input and MSB-justified output
1	1	LSB-justified 24 bits input and MSB-justified output

8.14.3 ADC INPUT CHANNEL SELECT

In the static pin mode pin IPSEL selects the ADC input channel.

Table 9 ADC input channel select

PIN IPSEL	CHANNEL SELECT
0	input channel 1 (pins VINL1 and VINR1)
1	input channel 2 (pins VINL2 and VINR2)

8.15 L3-bus interface

All digital processing features and system controlling features of the UDA1342TS can be controlled by a microcontroller via the L3-bus interface.

The controllable features are:

- Reset
- System clock frequency
- Data input and output format
- Multi purpose output
- ADC features
 - Operation mode control
 - Polarity control
 - Input amplifier gain control
 - Mixer control
 - DC filtering.
- DAC features
 - Power control
 - Polarity control
 - Input data oversampling rate
 - Mixer position selection
 - Mixer control
 - Silence detector
 - De-emphasis
 - Volume
 - Flat/min./max. switch
 - Bass boost
 - Treble
 - Mute
 - Quick mute mode.

8.15.1 INTRODUCTION

The exchange of data and control information between the microcontroller and the UDA1342TS is accomplished through a serial hardware interface comprising the following pins:

- L3DATA: microcontroller interface data line
- L3MODE: microcontroller interface mode line
- L3CLOCK: microcontroller interface clock line.

The UDA1342TS acts as a slave receiver or a slave transmitter. Therefore L3CLOCK and L3MODE lines transfer only input data and the L3DATA line transfers bidirectional data.

Audio CODEC

UDA1342TS

Information transfer via the microcontroller bus is organized LSB first and in accordance with the so called 'L3' format, in which two different modes of operation can be distinguished: address mode and data transfer mode.

Important:

- When the device is powered-up, at least one L3CLOCK pulse must be sent to the L3-bus interface to wake-up the interface prior to sending information to the device. This is only needed once after the device is powered-up.
- Inside the microcontroller there is a hand-shake mechanism which handles proper data transfer from the microcontroller clock to destination clock domains. This means that when data is sent to the microcontroller interface, the system clock must be running.
- The L3-bus interface is designed in such a way that data is clocked into the device (write mode) on the positive clock edge, while the device starts the output data (read mode) on the negative clock edge. The microcontroller must read the data from the device on the positive clock edge to ensure the data is always stable.

8.15.2 DEVICE ADDRESSING

The device address mode is used to select a device for subsequent data transfer. The address mode is characterized by L3MODE being LOW and a burst of 8 pulses on L3CLOCK, accompanied by 8 bits. The fundamental timing in the address mode is shown in Fig.13.

The device address consists of one byte, which is split up in two parts (see Table 10):

- Bits 0 and 1 are called Data Operation Mode (DOM) bits and represent the type of data transfer
- Bits 2 to 7 represent a 6-bit device address.

Table 10 L3-bus interface slave address

DOM		DEVICE ADDRESS					
LSB	BIT 1	BIT 2	BIT 3	BIT 4	BIT 5	BIT 6	MSB
R/W	1	IPSEL	0	1	0	0	0

The UDA1342TS can be set to different addresses (00 1000 or 10 1000) by setting pin IPSEL to HIGH or LOW level. In the event that the device receives a different address, it will deselect its microcontroller interface logic.

Basically, 2 types of data transfer can be defined: data transfer to the device and data transfer from the device (see Table 11).

Table 11 Selection of data transfer

DOM		TRANSFER
BIT 0	BIT 1	
0	0	not used
1	0	not used
0	1	data write or prepare read
1	1	data read

8.15.3 REGISTER ADDRESSING

After sending the device address, including the flags (DOM bits) whether the information is read or written, the data transfer mode is entered and one byte is sent with the destination register address (see Table 12) using 7 bits, and one bit which signals whether information will be read or written.

The fundamental timing for the data transfer mode is given in Fig.14.

Table 12 L3-bus register address

LSB	BIT 1	BIT 2	BIT 3	BIT 4	BIT 5	BIT 6	MSB
R/W	A6	A5	A4	A3	A2	A1	A0

Basically there are 3 cases for register addressing:

1. Register addressing for L3-bus write: the first bit is at logic 0 indicating a write action to the destination register, and is followed by 7 bits indicating the register address.
2. Prepare read addressing: the first bit of the byte is at logic 1, signalling data will be read from the register indicated.
3. Read action itself: in this case the device returns a register address prior to sending data from that register. When the first bit of the byte is at logic 0, the register address was valid and if the first bit is at logic 1 the register address was invalid.

Important:

1. Each time a new destination address needs to be written, the device address must be sent again.
2. When addressing the device for the first time after power-up of the device, at least one L3CLOCK cycle must be given to enable the L3-bus interface.

Audio CODEC

UDA1342TS

8.15.4 DATA WRITE MODE

The data write format is given in Table 13 and illustrated in Fig.9.

When writing data to a device four bytes must be sent:

1. One byte with the device address, being '01X0 1000' where 'X' stands for the IPSEL value, including '01' for signalling write to the device.
2. One byte starting with a logic 0 for signalling write followed by 7 bits indicating the register address.
3. One byte which is the Most Significant Data (MSD) byte 1.
4. One byte which is the Least Significant Data (LSD) byte 2.

8.15.5 DATA READ MODE

The data write format is given in Table 14 and illustrated in Fig.10.

When reading from the device, a prepare read must first be done. After the prepare read, the device address is sent again. The device then returns with the register address, indicating whether the address was valid or not, and the data of the register.

The data read mode is explained below:

1. One byte with the device address, being '01X0 1000' where 'X' stands for the IPSEL value, including '01' for signalling write to the device.
2. One byte is sent with the register address which needs to be read. This byte starts with a logic 1, which indicates that there will be a read action from the register.
3. One byte with the device address including '11' is sent to the device. The '11' indicates that the device must write data to the microcontroller.
4. The device now writes the requested register address on the L3-bus, indicating whether the requested register was valid (logic 0) or invalid (logic 1).
5. The device writes data from the requested register to the L3-bus with the MSD byte 1 first, followed by the LSD byte 2.

Table 13 L3-bus format for data write

L3MODE	DATA TYPE	FIRST IN TIME					LAST IN TIME			
		BIT 0	BIT 1	BIT 2	BIT 3	BIT 4	BIT 5	BIT 6	BIT 7	
Address	device address	0	1	IPSEL	0	1	0	0	0	
Data transfer 1	register address	0	A6	A5	A4	A3	A2	A1	A0	
Data transfer 2	MSD byte 1	D15	D14	D13	D12	D11	D10	D9	D8	
Data transfer 3	LSD byte 2	D7	D6	D5	D4	D3	D2	D1	D0	

Table 14 L3-bus format for prepare read and read data

L3MODE	DATA TYPE	FIRST IN TIME					LAST IN TIME			
		BIT 0	BIT 1	BIT 2	BIT 3	BIT 4	BIT 5	BIT 6	BIT 7	
Prepare read										
Address	device address	0	1	IPSEL	0	1	0	0	0	
Data transfer 1	register address	1	A6	A5	A4	A3	A2	A1	A0	
Read data										
Address	device address	1	1	IPSEL	0	1	0	0	0	
Data transfer 1	register address	0/1	A6	A5	A4	A3	A2	A1	A0	
Data transfer 2	MSD byte 1	D15	D14	D13	D12	D11	D10	D9	D8	
Data transfer 3	LSD byte 2	D7	D6	D5	D4	D3	D2	D1	D0	

Audio CODEC

UDA1342TS

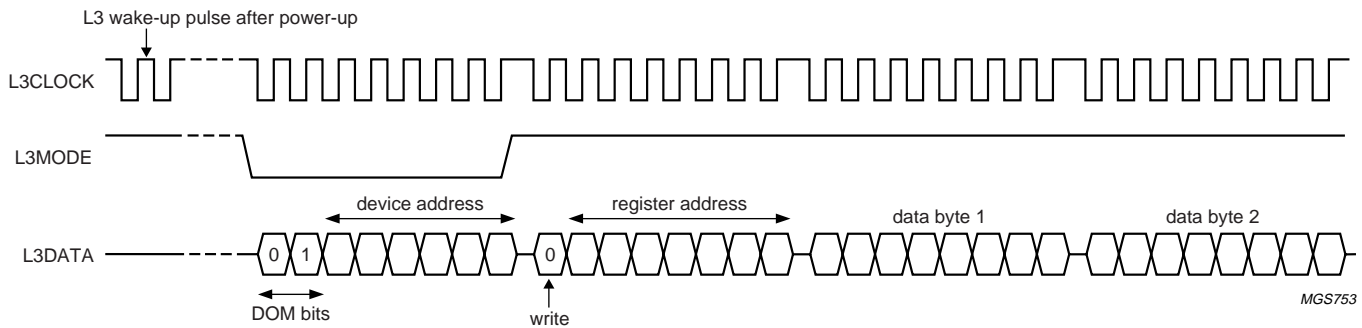

Fig.9 Data write mode for L3-bus version 2.

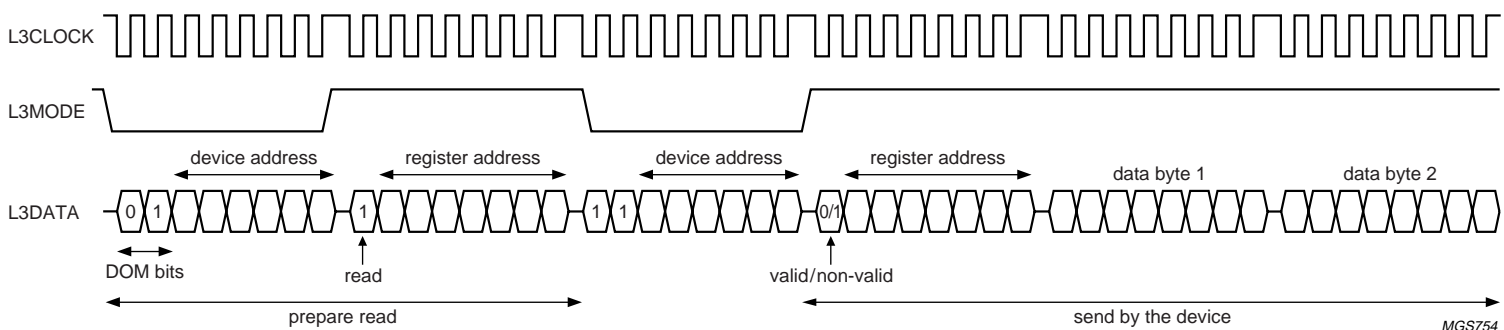

Fig.10 Data read mode for L3-bus version 2.

Audio CODEC

UDA1342TS

8.16 I²C-bus interface

Besides the L3-bus mode the UDA1342TS supports the I²C-bus mode; all the features can be controlled by the microcontroller with the same register addresses as used in the L3-bus mode.

The exchange of data and control information between the microcontroller and the UDA1342TS in the I²C-bus mode is accomplished through a serial hardware interface comprising the following pins and signals:

- L3CLOCK: Serial Clock Line (SCL)
- L3DATA: Serial Data line (SDA).

The clock and data timing of the I²C-bus transfer is shown in Fig.15.

8.16.1 ADDRESSING

Before any data is transmitted on the I²C-bus, the device which should respond is addressed first. The addressing is always done with the first byte transmitted after the START procedure (S).

8.16.2 SLAVE ADDRESS

The UDA1342TS acts as a slave receiver or a slave transmitter. Therefore, the clock signal SCL is only an input signal. The data signal SDA is an input or output signal (bidirectional line).

The UDA1342TS slave address format is shown in Table 15.

Table 15 I²C-bus slave address format

MSB	BIT 6	BIT 5	BIT 4	BIT 3	BIT 2	BIT 1	LSB
0	0	1	1	0	1	IPSEL	R/W

The slave address bit IPSEL corresponds to the hardware address pin IPSEL which allows selecting the slave address.

8.16.3 REGISTER ADDRESS

The UDA1342TS register address format is given in Table 16.

Table 16 I²C-bus register address format

MSB	BIT 6	BIT 5	BIT 4	BIT 3	BIT 2	BIT 1	LSB
0	A6	A5	A4	A3	A2	A1	A0

The register mapping of the I²C-bus and L3-bus interfaces is the same (see Section 9).

8.16.4 WRITE CYCLE

The write cycle is used to write data from the microcontroller to the internal registers. The I²C-bus format for a write cycle is shown in Table 17.

The device and register addresses are one byte each, data is always two bytes (2-bytes data).

The format of the write cycle is as follows:

1. The microcontroller starts with a START condition S.
2. The first byte (8 bits) contains the device address 0011 01X and a write command (bit R/\overline{W} = 0).
3. This is followed by an acknowledge (A) from the UDA1342TS.
4. The microcontroller then writes the register address (8 bits) where writing of the register content of the UDA1342TS must start.
5. The UDA1342TS acknowledges this register address.
6. The microcontroller sends 2-bytes data with the Most Significant Data (MSD) byte first and then the Least Significant Data (LSD) byte, where each byte is acknowledged by the UDA1342TS.
7. After the last acknowledge the UDA1342TS frees the I²C-bus and the microcontroller can generate a STOP condition (P).

Table 17 Master transmitter writes to UDA1342TS registers

			ACKNOWLEDGE FROM UDA1342TS																
	DEVICE ADDRESS	R/ \overline{W}		REGISTER ADDRESS		DATA ⁽¹⁾													
S	0011 01X	0	A	0XXX XXXX	A	MSD1	A	LSD1	A	MSD2	A	LSD2	A	MSDn	A	LSDn	A	P	
	8 bits			8 bits		8 bits		8 bits		8 bits		8 bits		8 bits		8 bits			

Note

1. Auto increment of the register address is carried out if repeated groups of 2 bytes are transmitted.

8.16.5 READ CYCLE

The read cycle is used to read data from the internal registers of the UDA1342TS to the microcontroller. The I²C-bus format for a read cycle is shown in Table 18.

The format of the read cycle is as follows:

1. The microcontroller starts with a START condition S.
2. The first byte (8 bits) contains the device address 001 01X and a write command (bit $R/\bar{W} = 0$).
3. This is followed by an acknowledge (A) from the UDA1342TS.
4. The microcontroller then writes the register address where reading of the register content of the UDA1342TS must start.
5. The UDA1342TS acknowledges this register address.
6. Then the microcontroller generates a repeated START (Sr).
7. Again the device address 0011 01X is given, but this time followed by a read command (bit $R/\bar{W} = 1$).
8. The UDA1342TS sends the two-byte data with the Most Significant Data (MSD) byte first and then the Least Significant Data (LSD) byte, where each byte is acknowledged by the microcontroller (master).
9. The microcontroller stops this cycle by generating a negative acknowledge (NA).
10. The UDA1342TS then frees the I²C-bus and the microcontroller can generate a STOP condition (P).

Table 18 Master transmitter reads from UDA1342TS registers

			ACKNOWLEDGE FROM UDA1342TS						ACKNOWLEDGE FROM MASTER													
	DEVICE ADDRESS	R/ \bar{W}		REGISTER ADDRESS			DEVICE ADDRESS	R/ \bar{W}		DATA ⁽¹⁾												
S	0011 01X	0	A	0XXX XXXX	A	Sr	0011 01X	1	A	MSD1	A	LSD1	A	MSD2	A	LSD2	A	MSDn	A	LSDn	NA	P
	8 bits			8 bits			8 bits			8 bits		8 bits		8 bits		8 bits		8 bits		8 bits		

Note

1. Auto increment of the register address is carried out if repeated groups of 2 bytes are transmitted.

Audio CODEC

UDA1342TS

9 REGISTER MAPPING

The addresses of the control registers with default values at Power-on reset are shown in Table 19. Functions of the registers are shown in Tables 20 to 45.

Table 19 Register map

ADDRESS	FUNCTION	D15	D14	D13	D12	D11	D10	D9	D8	D7	D6	D5	D4	D3	D2	D1	D0
00H	system	RST	QS	MDC	DC	AM2	AM1	AM0	PAD	0	SC1	SC0	IF2	IF1	IF0	DP	PDA
		–	0	0	1	1	0	1	0	0	0	0	0	0	0	0	1
01H	sub system	–	–	–	–	–	–	–	–	OS1	OS0	MPS	MIX	SD1	SD0	MP1	MP0
		–	–	–	–	–	–	–	–	0	0	0	0	0	0	0	0
02H to 0FH	reserved	–	–	–	–	–	–	–	–	–	–	–	–	–	–	–	–
10H	DAC features	M1	M0	BB3	BB2	BB1	BB0	TR1	TR0	SDS	MTB	MTA	MT	QM	DE2	DE1	DE0
		0	0	0	0	0	0	0	0	0	0	0	0	0	0	0	0
11H	DAC master volume	VL7	VL6	VL5	VL4	VL3	VL2	VL1	VL0	VR7	VR6	VR5	VR4	VR3	VR2	VR1	VR0
		0	0	0	0	0	0	0	0	0	0	0	0	0	0	0	0
12H	DAC mixer volume	VB7	VB6	VB5	VB4	VB3	VB2	VB1	VB0	VA7	VA6	VA5	VA4	VA3	VA2	VA1	VA0
		0	0	0	0	0	0	0	0	0	0	0	0	0	0	0	0
13H to 1FH	reserved	–	–	–	–	–	–	–	–	–	–	–	–	–	–	–	–
20H	ADC input and mixer gain channel 1	0	0	0	0	IA3	IA2	IA1	IA0	MA7	MA6	MA5	MA4	MA3	MA2	MA1	MA0
		0	0	0	0	0	0	0	0	0	0	0	0	0	0	0	0
21H	ADC input and mixer gain channel 2	0	0	0	0	IB3	IB2	IB1	IB0	MB7	MB6	MB5	MB4	MB3	MB2	MB1	MB0
		0	0	0	0	0	0	0	0	0	0	0	0	0	0	0	0
22H to 2FH	reserved	–	–	–	–	–	–	–	–	–	–	–	–	–	–	–	–
30H	evaluation	0	0	0	0	0	0	0	0	0	0	0	0	0	0	0	0
31H to FFH	reserved	–	–	–	–	–	–	–	–	–	–	–	–	–	–	–	–

Audio CODEC

UDA1342TS

9.1 Reset

A 1-bit value to initialize the L3-bus and I²C-bus registers except the system register (00H) with default settings by setting bit RST = 1.

Table 20 Reset bit

RST	FUNCTION
0	no reset
1	reset registers to default

9.2 Quick mode switch

A 1-bit value to enable the quick mode change of the ADC. The soft mode change works only between modes if bit AM2 = 1.

Table 21 Quick mode switch

QS	FUNCTION
0	soft mode change
1	quick mode change

9.3 Bypass mixer DC filter

A 1-bit value to disable the DC filter of the ADC mixer. This DC filter is in front of the mixer to prevent clipping inside the mixer due to DC signals.

Table 22 Mixer DC filtering

MDC	FUNCTION
0	enable mixer DC filtering
1	disable mixer DC filtering

9.4 DC filter

A 1-bit value to enable the DC filter of the ADC output. This DC filter is inside the decimation filter.

Table 23 DC-filtering

DC	FUNCTION
0	disable output DC filtering
1	enable output DC filtering

9.5 ADC mode

A 3-bit value to select the mode of the ADC.

Table 24 ADC mode

AM2	AM1	AM0	FUNCTION
0	0	0	ADC power-off
0	0	1	input 1 select (input 2 off)
0	1	0	input 2 select (input 1 off)
0	1	1	not used
1	0	0	channel swap and signal inversion
1	0	1	input 1 select (double differential mode)
1	1	0	input 2 select (double differential mode)
1	1	1	mixing mode

9.6 ADC polarity

A 1-bit value to control the ADC polarity.

Table 25 Polarity control of the ADC

PAD	FUNCTION
0	non-inverting
1	inverting

9.7 System clock frequency

A 2-bit value to select the external clock frequency.

Table 26 System clock frequency settings

SC1	SC0	FUNCTION
0	0	256f _s
0	1	384f _s
1	0	512f _s
1	1	768f _s

Audio CODEC

UDA1342TS

9.8 Data format

A 3-bit value to select the data format.

Table 27 Data format selection

IF2	IF1	IF0	FUNCTION
0	0	0	I ² S-bus
0	0	1	LSB-justified 16 bits
0	1	0	LSB-justified 20 bits
0	1	1	LSB-justified 24 bits
1	0	0	MSB-justified
1	0	1	LSB-justified 16 bits input and MSB-justified output
1	1	0	LSB-justified 20 bits input and MSB-justified output
1	1	1	LSB-justified 24 bits input and MSB-justified output

9.9 DAC power control

A 1-bit value to disable the DAC to reduce power consumption. The DAC power-off is not recommended when the DAC outputs are DC loaded.

Table 28 DAC power control

DP	FUNCTION
0	DAC power-off
1	DAC power-on

9.10 Input oversampling rate

A 2-bit value to select the oversampling rate of the input signal (see Table 32). In the quad speed input rate, care must be taken that the input signal is smaller than -5.67 dB (FS).

Table 32 Input oversampling rate

OS1	OS0	MODE	SAMPLING FREQUENCY	ADC	DAC FEATURES
0	0	single speed	16 to 110 kHz	supported	all digital filters and all features, including mixing are available
0	1	double speed	32 to 220 kHz	not supported	first digital filter is bypassed, only master volume and master mute features are available
1	0	quad speed	64 to 440 kHz	not supported	no mixing nor any sound feature is supported
1	1	reserved	–	–	–

9.11 DAC polarity

A 1-bit value to control the DAC polarity.

Table 29 Polarity control of DAC

PDA	FUNCTION
0	non-inverting
1	inverting

9.12 DAC mixing position switch

A 1-bit value to select the mixing position of the ADC signal in the DAC.

Table 30 DAC mixing position switch

MPS	FUNCTION
0	before sound features
1	after sound features

9.13 DAC mixer

A 1-bit value to enable the digital mixer of the DAC.

Table 31 DAC mixer

MIX	FUNCTION
0	disable mixer
1	enable mixer

Audio CODEC

UDA1342TS

9.14 Silence detection period

A 2-bit value to define the silence period for the silence detector.

Table 33 Silence detection period

SD1	SD0	FUNCTION
0	0	3200 samples
0	1	4800 samples
1	0	9600 samples
1	1	19200 samples

9.15 Multi purpose output

A 2-bit value to select the output signal on pin STATUS.

Table 34 Multi purpose output selection

MP1	MP0	FUNCTION
0	0	no output
0	1	overflow (ADC) detection
1	0	reserved
1	1	digital silence detection

9.16 Mode

A 2-bit value to program the mode of the sound processing filters of bass boost and treble.

Table 35 Flat/min./max. switch position

M1	M0	FUNCTION
0	0	flat
0	1	min.
1	0	min.
1	1	max.

9.17 Bass boost

A 4-bit value to program the bass boost settings. The used set depends on the setting of bits M1 and M0.

At $f_s = 44.1$ kHz the -3 dB point for minimum setting is 250 Hz and the -3 dB point for maximum setting is 300 Hz. The default value is 0000.

Table 36 Bass boost settings

BB3	BB2	BB1	BB0	BASS BOOST (dB)		
				FLAT	MIN.	MAX.
0	0	0	0	0	0	0
0	0	0	1	0	2	2
0	0	1	0	0	4	4
0	0	1	1	0	6	6
0	1	0	0	0	8	8
0	1	0	1	0	10	10
0	1	1	0	0	12	12
0	1	1	1	0	14	14
1	0	0	0	0	16	16
1	0	0	1	0	18	18
1	0	1	0	0	18	20
1	0	1	1	0	18	22
1	1	0	0	0	18	24
1	1	0	1	0	18	24
1	1	1	0	0	18	24
1	1	1	1	0	18	24

9.18 Treble

A 2-bit value to program the treble setting. The used set depends on the setting of bits M1 and M0. At $f_s = 44.1$ kHz the -3 dB point for minimum setting is 3.0 kHz and the -3 dB point for maximum setting is 1.5 kHz. The default value is 00.

Table 37 Treble settings

TR1	TR0	TREBLE (dB)		
		FLAT	MIN.	MAX.
0	0	0	0	0
0	1	0	2	2
1	0	0	4	4
1	1	0	6	6

Audio CODEC

UDA1342TS

9.19 Silence detector switch

A 1-bit value to enable the silence detector.

Table 38 Silence detector switch

SDS	FUNCTION
0	disable silence detector
1	enable silence detector

9.20 Mute

Three 1-bit values to enable the digital mute. Bit MT is the master mute, using bit MTA the signal from the digital interface can be soft muted when the DAC mixer is enabled and using bit MTB the signal from ADC can be soft muted.

Table 39 Mute

MT MTA MTB	FUNCTION
0	no muting
1	muting

9.21 Quick mute mode

A 1-bit value to enable the quick mute function of the master mute.

Table 40 Quick mute mode settings

QM	FUNCTION
0	soft mute mode
1	quick mute mode

9.22 De-emphasis

A 3-bit value to enable the digital de-emphasis filter.

Table 41 De-emphasis settings

DE2	DE1	DE0	FUNCTION
0	0	0	no de-emphasis
0	0	1	de-emphasis at $f_s = 32$ kHz
0	1	0	de-emphasis at $f_s = 44.1$ kHz
0	1	1	de-emphasis at $f_s = 48$ kHz
1	0	0	de-emphasis at $f_s = 96$ kHz

9.23 ADC input amplifier gain

Two 4-bit values to program the gain of the input amplifiers. Bits IA applies for input amplifier A and bits IB to input amplifier B.

Table 42 ADC input amplifier gain settings

IA3 IB3	IA2 IB2	IA1 IB1	IA0 IB0	AMPLIFIER GAIN (dB)
0	0	0	0	0
0	0	0	1	3
0	0	1	0	6
0	0	1	1	9
0	1	0	0	12
0	1	0	1	15
0	1	1	0	18
0	1	1	1	21
1	0	0	0	24

Audio CODEC

UDA1342TS

9.24 DAC volume control

Four 8-bit values to program the volume attenuations. The range is from 0 to –66 dB and $-\infty$ dB in steps of 0.25 dB. Bits VL and VR are master volumes for the left and right channels.

Table 43 DAC volume settings

VL7 VR7	VL6 VR6	VL5 VR5	VL4 VR4	VL3 VR3	VL2 VR2	VL1 VR1	VL0 VR0	VOLUME (dB)
0	0	0	0	0	0	0	0	0
0	0	0	0	0	0	0	1	–0.25
0	0	0	0	0	0	1	0	–0.50
0	0	0	0	0	0	1	1	–0.75
0	0	0	0	0	1	0	0	–1.00
:	:	:	:	:	:	:	:	:
1	1	0	0	0	1	0	0	–49.0
1	1	0	0	0	1	0	1	–49.25
1	1	0	0	0	1	1	0	–49.5
1	1	0	0	0	1	1	1	–49.75
1	1	0	0	1	0	0	0	–50.0
1	1	0	0	1	1	0	0	–52.0
1	1	0	1	0	0	0	0	–54.0
1	1	0	1	0	1	0	0	–57.0
1	1	0	1	1	0	0	0	–60.0
1	1	0	1	1	1	0	0	–66.0
1	1	1	0	0	0	0	0	$-\infty$
:	:	:	:	:	:	:	:	:
1	1	1	1	1	1	1	1	$-\infty$

9.25 DAC mixer volume control

Four 8-bit values to program the volume attenuations. The range is from 0 to –60 dB and $-\infty$ dB in steps of 0.25 dB. When the DAC mixer is enabled, the signal from the digital interface can be controlled by bits VA and the signal from the ADC can be controlled by bits VB.

Table 44 DAC volume settings

VA7 VB7	VA6 VB6	VA5 VB5	VA4 VB4	VA3 VB3	VA2 VB2	VA1 VB1	VA0 VB0	VOLUME (dB)
0	0	0	0	0	0	0	0	0
0	0	0	0	0	0	0	1	–0.25
0	0	0	0	0	0	1	0	–0.50
0	0	0	0	0	0	1	1	–0.75
0	0	0	0	0	1	0	0	–1.00
:	:	:	:	:	:	:	:	:
1	0	1	0	1	1	0	0	–43.0
1	0	1	0	1	1	0	1	–43.25

Audio CODEC

UDA1342TS

VA7 VB7	VA6 VB6	VA5 VB5	VA4 VB4	VA3 VB3	VA2 VB2	VA1 VB1	VA0 VB0	VOLUME (dB)
1	0	1	0	1	1	1	0	-43.5
1	0	1	0	1	1	1	1	-43.75
1	0	1	1	0	0	0	0	-44.0
1	0	1	1	0	1	0	0	-46.0
1	0	1	1	1	0	0	0	-48.0
1	0	1	1	1	1	0	0	-51.0
1	1	0	0	0	0	0	0	-54.0
1	1	0	0	0	1	0	0	-60.0
1	1	0	0	1	0	0	0	-∞
:	:	:	:	:	:	:	:	:
1	1	1	1	1	1	1	1	-∞

9.26 ADC mixer gain control

Two 8-bit values to program the channel 1 and 2 mixing, when the mixer mode is selected. Bits MA applies to channel 1 and bits MB to channel 2. The range is from +24 to -63.5 dB and -∞ dB in steps of 0.5 dB.

Table 45 ADC mixer gain settings

MA7 MB7	MA6 MB6	MA5 MB5	MA4 MB4	MA3 MB3	MA2 MB2	MA1 MB1	MA0 MB0	MIXER GAIN (dB)
0	0	1	1	0	0	0	0	+24.0
0	0	1	0	1	1	1	1	+23.5
0	0	1	0	1	1	1	0	+23.0
:	:	:	:	:	:	:	:	:
0	0	0	0	0	0	1	0	+1.0
0	0	0	0	0	0	0	1	+0.5
0	0	0	0	0	0	0	0	0
1	1	1	1	1	1	1	1	-0.5
:	:	:	:	:	:	:	:	:
1	0	0	0	0	1	0	0	-62.0
1	0	0	0	0	0	1	1	-62.5
1	0	0	0	0	0	1	0	-63.0
1	0	0	0	0	0	0	1	-63.5
1	0	0	0	0	0	0	0	-∞

Audio CODEC

UDA1342TS

10 LIMITING VALUES

In accordance with the Absolute Maximum Rating System (IEC 60134).

SYMBOL	PARAMETER	CONDITIONS	MIN.	MAX.	UNIT
V_{DD}	supply voltage	note 1	–	4	V
$T_{xtal(max)}$	maximum crystal temperature		–	150	°C
T_{stg}	storage temperature		–65	+125	°C
T_{amb}	ambient temperature		–40	+85	°C
V_{es}	electrostatic handling voltage	note 2	–1100	+1100	V
		note 3	–250	+250	V
$I_{lu(prot)}$	latch-up protection current	$T_{amb} = 125\text{ °C}$; $V_{DD} = 3.6\text{ V}$	–	200	mA
$I_{sc(DAC)}$	short-circuit current of DAC	$T_{amb} = 0\text{ °C}$; $V_{DD} = 3\text{ V}$; note 4			
		output short-circuited to $V_{SSA(DAC)}$	–	450	mA
		output short-circuited to $V_{DDA(DAC)}$	–	325	mA

Notes

- All supply connections must be made to the same power supply.
- Equivalent to discharging a 100 pF capacitor via a 1.5 k Ω series resistor.
- Equivalent to discharging a 200 pF capacitor via a 0.75 μ H series inductor.
- DAC operation after short-circuiting cannot be warranted.

11 HANDLING

Inputs and outputs are protected against electrostatic discharge in normal handling. However, to be totally safe, it is desirable to take normal precautions appropriate to handling MOS devices.

12 QUALITY SPECIFICATION

In accordance with “SNW-FQ-611-E”.

13 THERMAL CHARACTERISTICS

SYMBOL	PARAMETER	CONDITIONS	VALUE	UNIT
$R_{th(j-a)}$	thermal resistance from junction to ambient	in free air	90	K/W

14 DC CHARACTERISTICS

$V_{DDD} = V_{DDA(ADC)} = V_{DDA(DAC)} = 3.0\text{ V}$; $T_{amb} = 25\text{ °C}$; $R_L = 5\text{ k}\Omega$; all voltages measured with respect to ground; unless otherwise specified.

SYMBOL	PARAMETER	CONDITIONS	MIN.	TYP.	MAX.	UNIT
Supplies; note 1						
$V_{DDA(ADC)}$	ADC analog supply voltage		2.7	3.0	3.6	V
$V_{DDA(DAC)}$	DAC analog supply voltage		2.7	3.0	3.6	V
V_{DDD}	digital supply voltage		2.7	3.0	3.6	V

Audio CODEC

UDA1342TS

SYMBOL	PARAMETER	CONDITIONS	MIN.	TYP.	MAX.	UNIT
I _{DDA(ADC)}	ADC analog supply current	1 ADC + 1 PGA enabled	–	10	–	mA
		2 ADCs + 2 PGAs enabled	–	20	–	mA
		all ADCs + all PGAs power-down	–	200	–	μA
I _{DDA(DAC)}	DAC analog supply current	operating	–	6.0	–	mA
		DAC power-down	–	250	–	μA
I _{DDD}	digital supply current	operating	–	9.0	–	mA
		ADC power-down	–	4.5	–	mA
		DAC power-down	–	5.5	–	mA
Digital input pins (5 V tolerant TTL compatible)						
V _{IH}	HIGH-level input voltage		2.0	–	5.5	V
V _{IL}	LOW-level input voltage		–0.5	–	+0.8	V
I _{LI}	input leakage current		–	–	1	μA
C _i	input capacitance		–	–	10	pF
Digital output pins						
V _{OH}	HIGH-level output voltage	I _{OH} = –2 mA	0.85V _{DDD}	–	–	V
V _{OL}	LOW-level output voltage	I _{OL} = 2 mA	–	–	0.4	V
Reference voltage						
V _{ref}	reference voltage	with respect to V _{SSA(ADC)} ; note 2	0.45V _{DDA}	0.5V _{DDA}	0.55V _{DDA}	V
R _{O(Vref)}	output resistance on pin V _{ref}		–	5	–	kΩ
Analog-to-digital converter						
V _{ADCP}	positive reference voltage of the ADC		–	V _{DDA(ADC)}	–	V
V _{ADCN}	negative reference voltage of the ADC		–	0.0	–	V
R _i	input resistance		–	10	–	kΩ
C _i	input capacitance		–	24	–	pF
Digital-to-analog converter						
I _{o(max)}	maximum output current	(THD + N)/S < 0.1%	–	tbF	–	mA
R _L	load resistance		3	–	–	kΩ
C _L	load capacitance	note 3	–	–	50	pF

Notes

1. All supply connections must be made to the same power supply unit.
2. V_{DDA} = V_{DDA(DAC)} = V_{DDA(ADC)}.
3. When higher capacitive loads must be driven, a 100 Ω resistor must be connected in series with the DAC output in order to prevent oscillations in the output operational amplifier.

Audio CODEC

UDA1342TS

15 AC CHARACTERISTICS

$V_{DD} = V_{DDA(ADC)} = V_{DDA(DAC)} = 3.0\text{ V}$; $f_i = 1\text{ kHz}$ at -1 dB ; $T_{amb} = 25\text{ °C}$; $R_L = 5\text{ k}\Omega$; all voltages measured with respect to ground; unless otherwise specified.

SYMBOL	PARAMETER	CONDITIONS	MIN.	TYP.	MAX.	UNIT	
Analog-to-digital converter							
$V_{i(rms)}$	input voltage (RMS value)	0 dB setting	–	900	–	mV	
		3 dB setting	–	640	–	mV	
		6 dB setting	–	450	–	mV	
		9 dB setting	–	320	–	mV	
		12 dB setting	–	225	–	mV	
		15 dB setting	–	160	–	mV	
		18 dB setting	–	122.5	–	mV	
		21 dB setting	–	80	–	mV	
		24 dB setting	–	61.25	–	mV	
ΔV_i	unbalance between channels		–	<0.1	–	dB	
$(THD + N)/S_{48}$	total harmonic distortion-plus-noise to signal ratio at $f_s = 48\text{ kHz}$	normal mode; at -1 dB					
		0 dB setting	–	–90	–	dB	
		3 dB setting	–	tbf	–	dB	
		6 dB setting	–	tbf	–	dB	
		9 dB setting	–	tbf	–	dB	
		12 dB setting	–	tbf	–	dB	
		15 dB setting	–	tbf	–	dB	
		18 dB setting	–	tbf	–	dB	
		21 dB setting	–	tbf	–	dB	
		24 dB setting	–	tbf	–	dB	
		normal mode; at -60 dB ; A-weighted					
		0 dB setting	–	–40	–	dB	
		3 dB setting	–	tbf	–	dB	
		6 dB setting	–	tbf	–	dB	
		9 dB setting	–	tbf	–	dB	
		12 dB setting	–	tbf	–	dB	
		15 dB setting	–	tbf	–	dB	
		18 dB setting	–	tbf	–	dB	
		21 dB setting	–	tbf	–	dB	
		24 dB setting	–	tbf	–	dB	
		double differential mode					
		at 0 dB gain	–	–93	–	dB	
		at 0 dB gain; -60 dB input; A-weighted	–	–41	–	dB	

Audio CODEC

UDA1342TS

SYMBOL	PARAMETER	CONDITIONS	MIN.	TYP.	MAX.	UNIT
(THD + N)/S ₉₆	total harmonic distortion-plus-noise to signal ratio at f _s = 96 kHz	normal mode	–	–84	–	dB
		at 0 dB gain at –60 dB; A-weighted	–	–40	–	dB
S/N ₄₈	signal-to-noise ratio at f _s = 48 kHz	V _i = 0 V; A-weighted normal mode	–	100	–	dB
		double differential mode	–	101	–	dB
S/N ₉₆	signal-to-noise ratio at f _s = 96 kHz	V _i = 0 V; A-weighted; normal mode	–	99	–	dB
α _{CS}	channel separation		–	100	–	dB
PSRR	power supply rejection ratio	f _{ripple} = 1 kHz; V _{ripple} = 30 mV (p-p)	–	30	–	dB
Digital-to-analog converter						
V _{o(rms)}	output voltage (RMS value)	at 0 dB (FS) digital input	–	0.9	–	V
ΔV _o	unbalance between channels		–	<0.1	–	dB
(THD+N)/S ₄₈	total harmonic distortion-plus-noise to signal ratio at f _s = 48 kHz	at 0 dB	–	–90	–	dB
		at –60 dB; A-weighted	–	–40	–	dB
(THD+N)/S ₉₆	total harmonic distortion-plus-noise to signal ratio at f _s = 96 kHz	at 0 dB	–	–83	–	dB
		at –60 dB; A-weighted	–	–39	–	dB
S/N ₄₈	signal-to-noise ratio at f _s = 48 kHz	code = 0; A-weighted	–	100	–	dB
S/N ₉₆	signal-to-noise at f _s = 96 kHz	code = 0; A-weighted	–	99	–	dB
α _{CS}	channel separation		–	100	–	dB
PSRR	power supply rejection ratio	f _{ripple} = 1 kHz; V _{ripple} = 30 mV (p-p)	–	60	–	dB

Audio CODEC

UDA1342TS

16 TIMING

$V_{DD} = V_{DDA(ADC)} = V_{DDA(DAC)} = 2.7$ to 3.6 V; $T_{amb} = -20$ to $+85$ °C; all voltages referenced to ground; unless otherwise specified.

SYMBOL	PARAMETER	CONDITIONS	MIN.	TYP.	MAX.	UNIT
System clock timing; note 1 (see Fig.11)						
T_{sys}	system clock cycle time	$f_{sys} = 256f_s$	35	81	250	ns
		$f_{sys} = 384f_s$	23	54	170	ns
		$f_{sys} = 512f_s$	17	41	130	ns
		$f_{sys} = 768f_s$	17	27	90	ns
t_{CWL}	system clock LOW time	$f_{sys} < 19.2$ MHz	$0.3T_{sys}$	–	$0.7T_{sys}$	ns
		$f_{sys} \geq 19.2$ MHz	$0.4T_{sys}$	–	$0.6T_{sys}$	ns
t_{CWH}	system clock HIGH time	$f_{sys} < 19.2$ MHz	$0.3T_{sys}$	–	$0.7T_{sys}$	ns
		$f_{sys} \geq 19.2$ MHz	$0.4T_{sys}$	–	$0.6T_{sys}$	ns
Serial interface input/output data timing (see Fig.12)						
f_{BCK}	bit clock frequency		–	–	$128f_s$	Hz
$T_{cy(BCK)}$	bit clock cycle time	$T_{cy(s)} =$ sample frequency cycle time	–	–	$\frac{1}{128}T_{cy(s)}$	s
t_{BCKH}	bit clock HIGH time		30	–	–	ns
t_{BCKL}	bit clock LOW time		30	–	–	ns
t_r	rise time		–	–	20	ns
t_f	fall time		–	–	20	ns
$t_{su(WS)}$	word select set-up time		10	–	–	ns
$t_{h(WS)}$	word select hold time		10	–	–	ns
$t_{su(DATAI)}$	data input set-up time		10	–	–	ns
$t_{h(DATAI)}$	data input hold time		10	–	–	ns
$t_{h(DATAO)}$	data output hold time		0	–	–	ns
$t_d(DATAO-BCK)$	data output to bit clock delay		–	–	30	ns
$t_d(DATAO-WS)$	data output to word select delay		–	–	30	ns
L3-bus interface timing (see Figs 13 and 14)						
t_r	rise time	note 2	–	–	10	ns/V
t_f	fall time	note 2	–	–	10	ns/V
$T_{cy(CLK)L3}$	L3CLOCK cycle time	note 3	500	–	–	ns
$t_{CLK(L3)H}$	L3CLOCK HIGH time		250	–	–	ns
$t_{CLK(L3)L}$	L3CLOCK LOW time		250	–	–	ns
$t_{su(L3)A}$	L3MODE set-up time in address mode		190	–	–	ns
$t_{h(L3)A}$	L3MODE hold time in address mode		190	–	–	ns
$t_{su(L3)D}$	L3MODE set-up time in data transfer mode		190	–	–	ns
$t_{h(L3)D}$	L3MODE hold time in data transfer mode		190	–	–	ns

Audio CODEC

UDA1342TS

SYMBOL	PARAMETER	CONDITIONS	MIN.	TYP.	MAX.	UNIT
$t_{\text{stp(L3)}}$	L3MODE stop time in data transfer mode		190	–	–	ns
$t_{\text{su(L3)DA}}$	L3DATA set-up time in address and data transfer mode		190	–	–	ns
$t_{\text{h(L3)DA}}$	L3DATA hold time in address and data transfer mode		30	–	–	ns
$t_{\text{su(L3)R}}$	L3DATA set-up time for read data		50	–	–	ns
$t_{\text{h(L3)R}}$	L3DATA hold time for read data		360	–	–	ns
$t_{\text{en(L3)R}}$	L3DATA enable time for read data		380	–	–	ns
$t_{\text{dis(L3)R}}$	L3DATA disable time for read data		50	–	–	ns
I²C-bus interface timing (see Fig.15)						
f_{SCL}	SCL clock frequency		0	–	400	kHz
t_{LOW}	SCL LOW time		1.3	–	–	μs
t_{HIGH}	SCL HIGH time		0.6	–	–	μs
t_{r}	rise time SDA and SCL	note 4	$20 + 0.1C_{\text{b}}$	–	300	ns
t_{f}	fall time SDA and SCL	note 4	$20 + 0.1C_{\text{b}}$	–	300	ns
$t_{\text{HD;STA}}$	hold time START condition	note 5	0.6	–	–	μs
$t_{\text{SU;STA}}$	set-up time repeated START		0.6	–	–	μs
$t_{\text{SU;STO}}$	set-up time STOP condition		0.6	–	–	μs
t_{BUF}	bus free time between a STOP and START condition		1.3	–	–	μs
$t_{\text{SU;DAT}}$	data set-up time		100	–	–	ns
$t_{\text{HD;DAT}}$	data hold time		0	–	–	μs
t_{SP}	pulse width of spikes	note 6	0	–	50	ns
C_{b}	capacitive load for each bus line		–	–	400	pF

Notes

1. The typical value of the timing is specified at 48 kHz sampling frequency.
2. In order to prevent digital noise interfering with the L3-bus communication, it is best to have the rise and fall times as small as possible.
3. When the sampling frequency is below 32 kHz, the L3CLOCK cycle must be limited to $\frac{1}{64f_{\text{s}}}$ cycle.
4. C_{b} is the total capacitance of one bus line in pF. The maximum capacitive load for each bus line is 400 pF.
5. After this period, the first clock pulse is generated.
6. To be suppressed by the input filter.

Audio CODEC

UDA1342TS

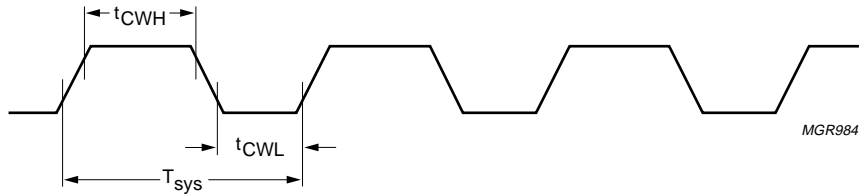

Fig.11 Timing of system clock.

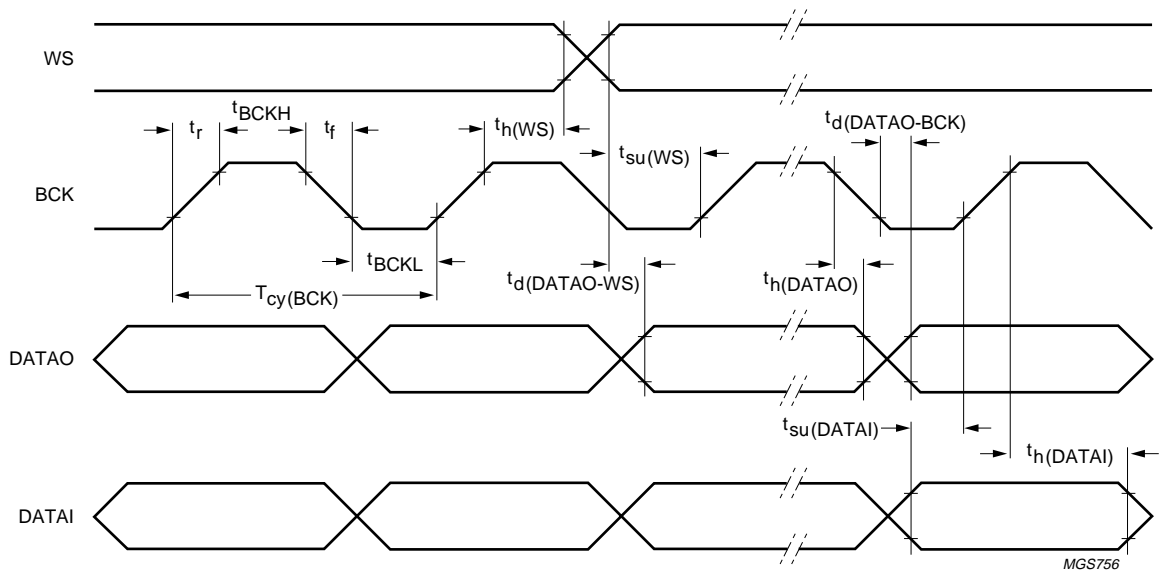
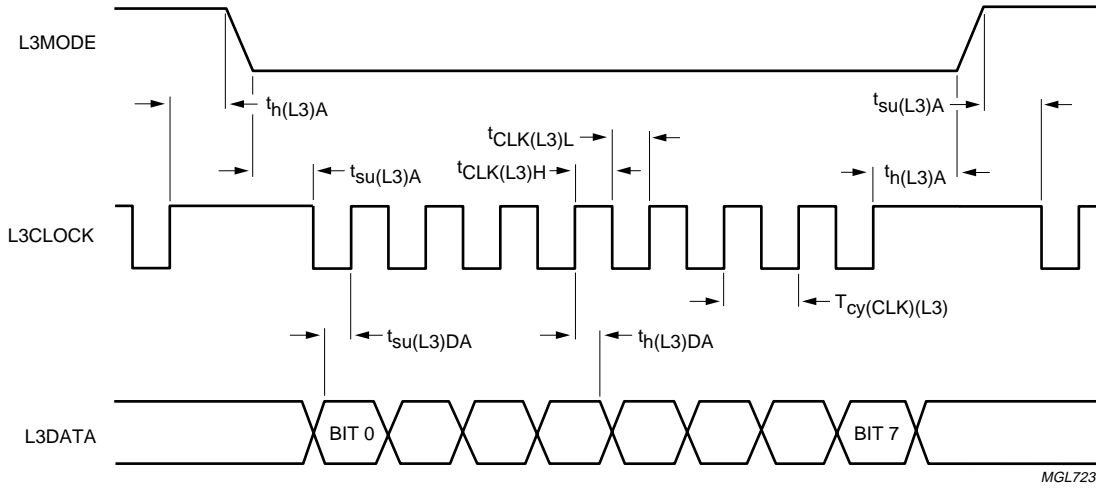

Fig.12 Serial interface input data timing.

Audio CODEC

UDA1342TS



MGL723

Fig.13 Timing of address mode.

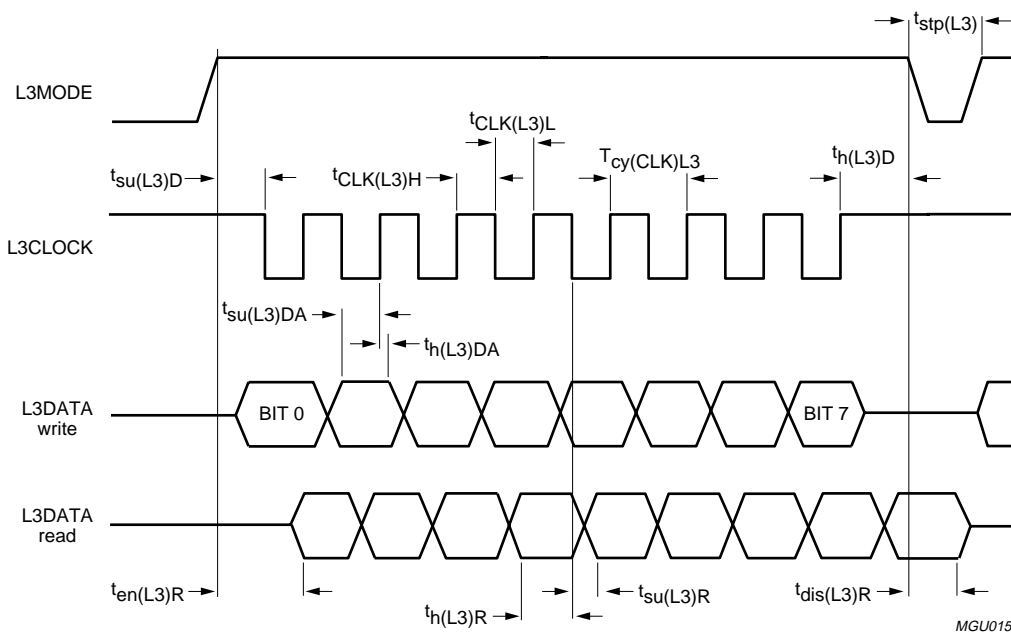

MGU015

Fig.14 Timing of data transfer mode for write and read.

Audio CODEC

UDA1342TS

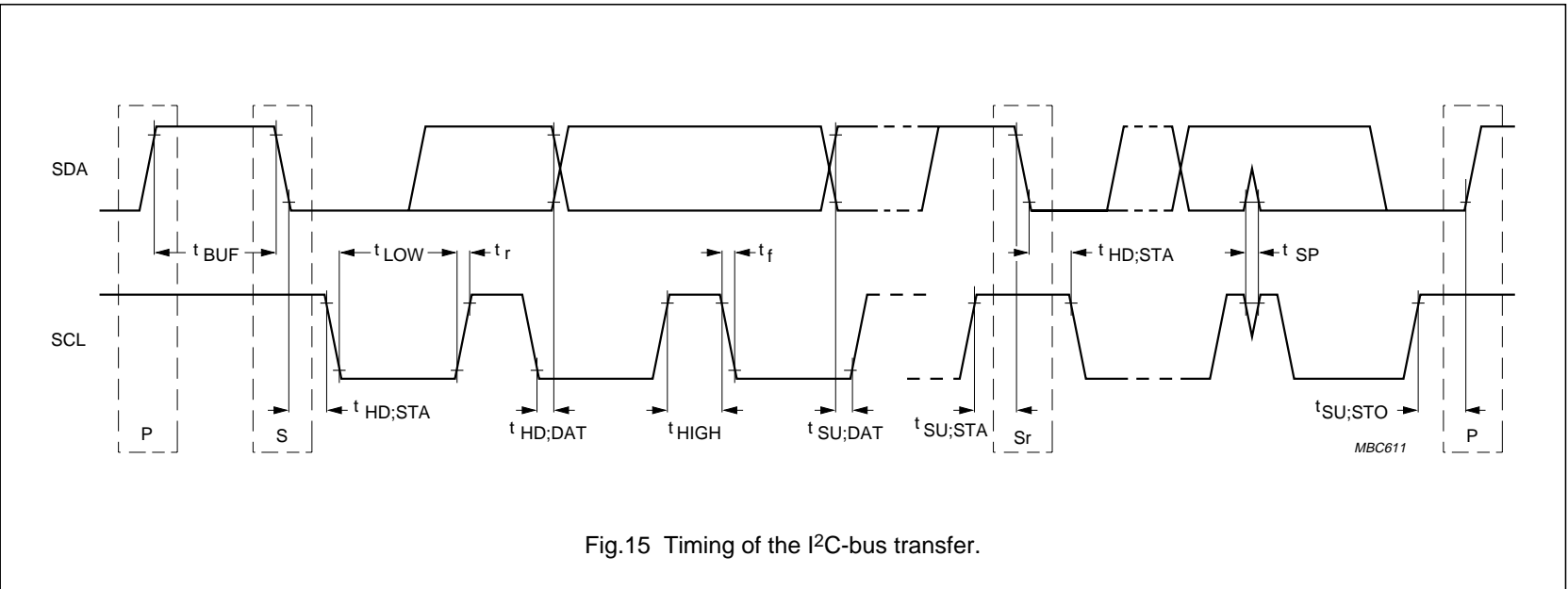

Fig.15 Timing of the I²C-bus transfer.

Audio CODEC

UDA1342TS

17 APPLICATION INFORMATION

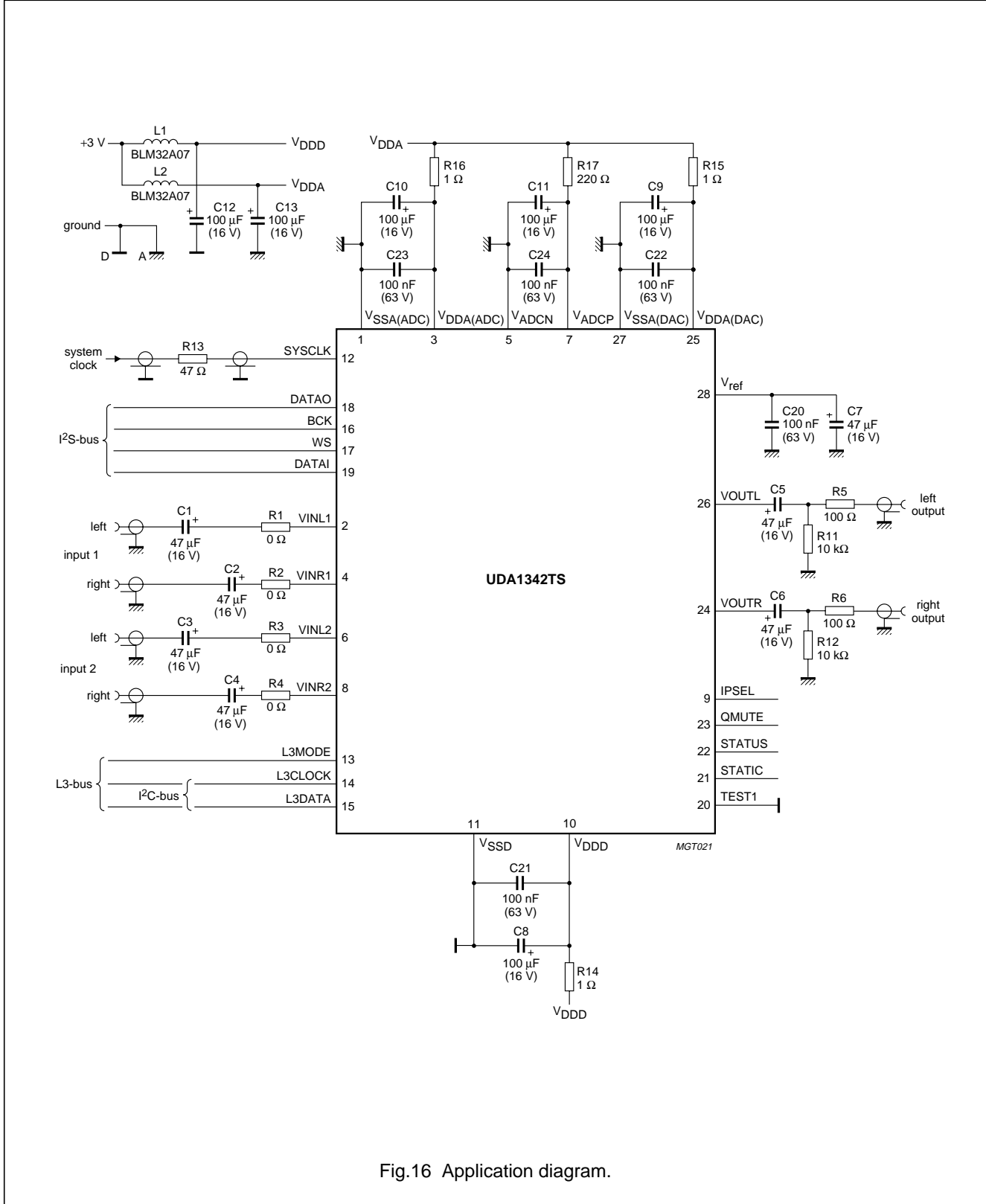

Fig.16 Application diagram.

Audio CODEC

UDA1342TS

18 PACKAGE OUTLINE

SSOP28: plastic shrink small outline package; 28 leads; body width 5.3 mm

SOT341-1

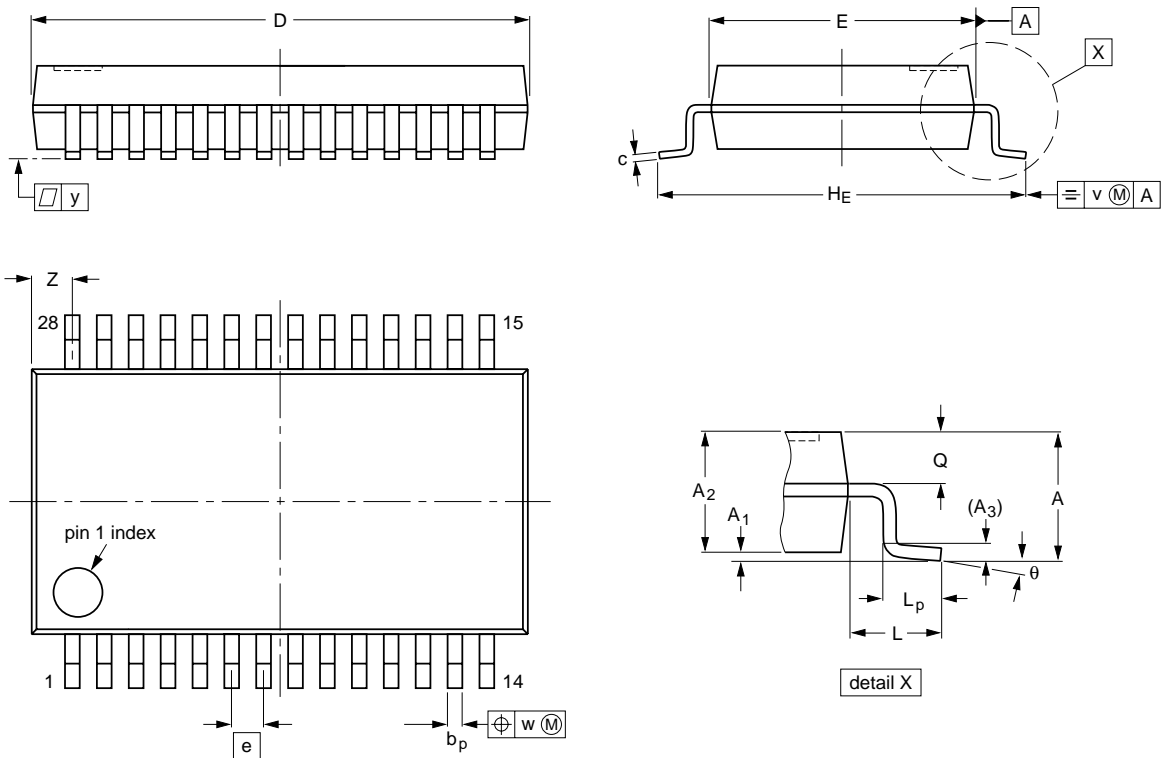

DIMENSIONS (mm are the original dimensions)

UNIT	A max.	A ₁	A ₂	A ₃	b _p	c	D ⁽¹⁾	E ⁽¹⁾	e	H _E	L	L _p	Q	v	w	y	z ⁽¹⁾	θ
mm	2.0	0.21 0.05	1.80 1.65	0.25	0.38 0.25	0.20 0.09	10.4 10.0	5.4 5.2	0.65	7.9 7.6	1.25	1.03 0.63	0.9 0.7	0.2	0.13	0.1	1.1 0.7	8° 0°

Note

1. Plastic or metal protrusions of 0.20 mm maximum per side are not included.

OUTLINE VERSION	REFERENCES				EUROPEAN PROJECTION	ISSUE DATE
	IEC	JEDEC	EIAJ			
SOT341-1		MO-150				95-02-04 99-12-27

Audio CODEC

UDA1342TS

19 SOLDERING**19.1 Introduction to soldering surface mount packages**

This text gives a very brief insight to a complex technology. A more in-depth account of soldering ICs can be found in our *"Data Handbook IC26; Integrated Circuit Packages"* (document order number 9398 652 90011).

There is no soldering method that is ideal for all surface mount IC packages. Wave soldering is not always suitable for surface mount ICs, or for printed-circuit boards with high population densities. In these situations reflow soldering is often used.

19.2 Reflow soldering

Reflow soldering requires solder paste (a suspension of fine solder particles, flux and binding agent) to be applied to the printed-circuit board by screen printing, stencilling or pressure-syringe dispensing before package placement.

Several methods exist for reflowing; for example, infrared/convection heating in a conveyor type oven. Throughput times (preheating, soldering and cooling) vary between 100 and 200 seconds depending on heating method.

Typical reflow peak temperatures range from 215 to 250 °C. The top-surface temperature of the packages should preferably be kept below 230 °C.

19.3 Wave soldering

Conventional single wave soldering is not recommended for surface mount devices (SMDs) or printed-circuit boards with a high component density, as solder bridging and non-wetting can present major problems.

To overcome these problems the double-wave soldering method was specifically developed.

If wave soldering is used the following conditions must be observed for optimal results:

- Use a double-wave soldering method comprising a turbulent wave with high upward pressure followed by a smooth laminar wave.
- For packages with leads on two sides and a pitch (e):
 - larger than or equal to 1.27 mm, the footprint longitudinal axis is **preferred** to be parallel to the transport direction of the printed-circuit board;
 - smaller than 1.27 mm, the footprint longitudinal axis **must** be parallel to the transport direction of the printed-circuit board.

The footprint must incorporate solder thieves at the downstream end.

- For packages with leads on four sides, the footprint must be placed at a 45° angle to the transport direction of the printed-circuit board. The footprint must incorporate solder thieves downstream and at the side corners.

During placement and before soldering, the package must be fixed with a droplet of adhesive. The adhesive can be applied by screen printing, pin transfer or syringe dispensing. The package can be soldered after the adhesive is cured.

Typical dwell time is 4 seconds at 250 °C.

A mildly-activated flux will eliminate the need for removal of corrosive residues in most applications.

19.4 Manual soldering

Fix the component by first soldering two diagonally-opposite end leads. Use a low voltage (24 V or less) soldering iron applied to the flat part of the lead. Contact time must be limited to 10 seconds at up to 300 °C.

When using a dedicated tool, all other leads can be soldered in one operation within 2 to 5 seconds between 270 and 320 °C.

Audio CODEC

UDA1342TS

19.5 Suitability of surface mount IC packages for wave and reflow soldering methods

PACKAGE	SOLDERING METHOD	
	WAVE	REFLOW ⁽¹⁾
BGA, LFBGA, SQFP, TFBGA	not suitable	suitable
HBCC, HLQFP, HSQFP, HSOP, HTQFP, HTSSOP, SMS	not suitable ⁽²⁾	suitable
PLCC ⁽³⁾ , SO, SOJ	suitable	suitable
LQFP, QFP, TQFP	not recommended ⁽³⁾⁽⁴⁾	suitable
SSOP, TSSOP, VSO	not recommended ⁽⁵⁾	suitable

Notes

1. All surface mount (SMD) packages are moisture sensitive. Depending upon the moisture content, the maximum temperature (with respect to time) and body size of the package, there is a risk that internal or external package cracks may occur due to vaporization of the moisture in them (the so called popcorn effect). For details, refer to the Drypack information in the *“Data Handbook IC26; Integrated Circuit Packages; Section: Packing Methods”*.
2. These packages are not suitable for wave soldering as a solder joint between the printed-circuit board and heatsink (at bottom version) can not be achieved, and as solder may stick to the heatsink (on top version).
3. If wave soldering is considered, then the package must be placed at a 45° angle to the solder wave direction. The package footprint must incorporate solder thieves downstream and at the side corners.
4. Wave soldering is only suitable for LQFP, TQFP and QFP packages with a pitch (e) equal to or larger than 0.8 mm; it is definitely not suitable for packages with a pitch (e) equal to or smaller than 0.65 mm.
5. Wave soldering is only suitable for SSOP and TSSOP packages with a pitch (e) equal to or larger than 0.65 mm; it is definitely not suitable for packages with a pitch (e) equal to or smaller than 0.5 mm.

Audio CODEC

UDA1342TS

20 DATA SHEET STATUS

DATA SHEET STATUS	PRODUCT STATUS	DEFINITIONS ⁽¹⁾
Objective specification	Development	This data sheet contains the design target or goal specifications for product development. Specification may change in any manner without notice.
Preliminary specification	Qualification	This data sheet contains preliminary data, and supplementary data will be published at a later date. Philips Semiconductors reserves the right to make changes at any time without notice in order to improve design and supply the best possible product.
Product specification	Production	This data sheet contains final specifications. Philips Semiconductors reserves the right to make changes at any time without notice in order to improve design and supply the best possible product.

Note

1. Please consult the most recently issued data sheet before initiating or completing a design.

21 DEFINITIONS

Short-form specification — The data in a short-form specification is extracted from a full data sheet with the same type number and title. For detailed information see the relevant data sheet or data handbook.

Limiting values definition — Limiting values given are in accordance with the Absolute Maximum Rating System (IEC 60134). Stress above one or more of the limiting values may cause permanent damage to the device. These are stress ratings only and operation of the device at these or at any other conditions above those given in the Characteristics sections of the specification is not implied. Exposure to limiting values for extended periods may affect device reliability.

Application information — Applications that are described herein for any of these products are for illustrative purposes only. Philips Semiconductors make no representation or warranty that such applications will be suitable for the specified use without further testing or modification.

22 DISCLAIMERS

Life support applications — These products are not designed for use in life support appliances, devices, or systems where malfunction of these products can reasonably be expected to result in personal injury. Philips Semiconductors customers using or selling these products for use in such applications do so at their own risk and agree to fully indemnify Philips Semiconductors for any damages resulting from such application.

Right to make changes — Philips Semiconductors reserves the right to make changes, without notice, in the products, including circuits, standard cells, and/or software, described or contained herein in order to improve design and/or performance. Philips Semiconductors assumes no responsibility or liability for the use of any of these products, conveys no licence or title under any patent, copyright, or mask work right to these products, and makes no representations or warranties that these products are free from patent, copyright, or mask work right infringement, unless otherwise specified.

23 PURCHASE OF PHILIPS I²C COMPONENTS

Purchase of Philips I²C components conveys a license under the Philips' I²C patent to use the components in the I²C system provided the system conforms to the I²C specification defined by Philips. This specification can be ordered using the code 9398 393 40011.

Audio CODEC

UDA1342TS

NOTES

Audio CODEC

UDA1342TS

NOTES

Philips Semiconductors – a worldwide company

Argentina: see South America

Australia: 3 Figtree Drive, HOMEBUSH, NSW 2140,
Tel. +61 2 9704 8141, Fax. +61 2 9704 8139

Austria: Computerstr. 6, A-1101 WIEN, P.O. Box 213,
Tel. +43 1 60 101 1248, Fax. +43 1 60 101 1210

Belarus: Hotel Minsk Business Center, Bld. 3, r. 1211, Volodarski Str. 6,
220050 MINSK, Tel. +375 172 20 0733, Fax. +375 172 20 0773

Belgium: see The Netherlands

Brazil: see South America

Bulgaria: Philips Bulgaria Ltd., Energoproject, 15th floor,
51 James Bourchier Blvd., 1407 SOFIA,
Tel. +359 2 68 9211, Fax. +359 2 68 9102

Canada: PHILIPS SEMICONDUCTORS/COMPONENTS,
Tel. +1 800 234 7381, Fax. +1 800 943 0087

China/Hong Kong: 501 Hong Kong Industrial Technology Centre,
72 Tat Chee Avenue, Kowloon Tong, HONG KONG,
Tel. +852 2319 7888, Fax. +852 2319 7700

Colombia: see South America

Czech Republic: see Austria

Denmark: Sydhavnsgade 23, 1780 COPENHAGEN V,
Tel. +45 33 29 3333, Fax. +45 33 29 3905

Finland: Sinikalliontie 3, FIN-02630 ESPOO,
Tel. +358 9 615 800, Fax. +358 9 6158 0920

France: 51 Rue Carnot, BP317, 92156 SURESNES Cedex,
Tel. +33 1 4099 6161, Fax. +33 1 4099 6427

Germany: Hammerbrookstraße 69, D-20097 HAMBURG,
Tel. +49 40 2353 60, Fax. +49 40 2353 6300

Hungary: see Austria

India: Philips INDIA Ltd, Band Box Building, 2nd floor,
254-D, Dr. Annie Besant Road, Worli, MUMBAI 400 025,
Tel. +91 22 493 8541, Fax. +91 22 493 0966

Indonesia: PT Philips Development Corporation, Semiconductors Division,
Gedung Philips, Jl. Buncit Raya Kav.99-100, JAKARTA 12510,
Tel. +62 21 794 0040 ext. 2501, Fax. +62 21 794 0080

Ireland: Newstead, Clonskeagh, DUBLIN 14,
Tel. +353 1 7640 000, Fax. +353 1 7640 200

Israel: RAPAC Electronics, 7 Kehilat Saloniki St, PO Box 18053,
TEL AVIV 61180, Tel. +972 3 645 0444, Fax. +972 3 649 1007

Italy: PHILIPS SEMICONDUCTORS, Via Casati, 23 - 20052 MONZA (MI),
Tel. +39 039 203 6838, Fax +39 039 203 6800

Japan: Philips Bldg 13-37, Kohnan 2-chome, Minato-ku,
TOKYO 108-8507, Tel. +81 3 3740 5130, Fax. +81 3 3740 5057

Korea: Philips House, 260-199 Itaewon-dong, Yongsan-ku, SEOUL,
Tel. +82 2 709 1412, Fax. +82 2 709 1415

Malaysia: No. 76 Jalan Universiti, 46200 PETALING JAYA, SELANGOR,
Tel. +60 3 750 5214, Fax. +60 3 757 4880

Mexico: 5900 Gateway East, Suite 200, EL PASO, TEXAS 79905,
Tel. +9-5 800 234 7381, Fax +9-5 800 943 0087

Middle East: see Italy

Netherlands: Postbus 90050, 5600 PB EINDHOVEN, Bldg. VB,
Tel. +31 40 27 82785, Fax. +31 40 27 88399

New Zealand: 2 Wagener Place, C.P.O. Box 1041, AUCKLAND,
Tel. +64 9 849 4160, Fax. +64 9 849 7811

Norway: Box 1, Manglerud 0612, OSLO,
Tel. +47 22 74 8000, Fax. +47 22 74 8341

Pakistan: see Singapore

Philippines: Philips Semiconductors Philippines Inc.,
106 Valero St. Salcedo Village, P.O. Box 2108 MCC, MAKATI,
Metro MANILA, Tel. +63 2 816 6380, Fax. +63 2 817 3474

Poland: Al.Jerozolimskie 195 B, 02-222 WARSAW,
Tel. +48 22 5710 000, Fax. +48 22 5710 001

Portugal: see Spain

Romania: see Italy

Russia: Philips Russia, Ul. Usatcheva 35A, 119048 MOSCOW,
Tel. +7 095 755 6918, Fax. +7 095 755 6919

Singapore: Lorong 1, Toa Payoh, SINGAPORE 319762,
Tel. +65 350 2538, Fax. +65 251 6500

Slovakia: see Austria

Slovenia: see Italy

South Africa: S.A. PHILIPS Pty Ltd., 195-215 Main Road Martindale,
2092 JOHANNESBURG, P.O. Box 58088 Newville 2114,
Tel. +27 11 471 5401, Fax. +27 11 471 5398

South America: Al. Vicente Pinzon, 173, 6th floor,
04547-130 SÃO PAULO, SP, Brazil,
Tel. +55 11 821 2333, Fax. +55 11 821 2382

Spain: Balmes 22, 08007 BARCELONA,
Tel. +34 93 301 6312, Fax. +34 93 301 4107

Sweden: Kottbygatan 7, Akalla, S-16485 STOCKHOLM,
Tel. +46 8 5985 2000, Fax. +46 8 5985 2745

Switzerland: Allmendstrasse 140, CH-8027 ZÜRICH,
Tel. +41 1 488 2741 Fax. +41 1 488 3263

Taiwan: Philips Semiconductors, 6F, No. 96, Chien Kuo N. Rd., Sec. 1,
TAIPEI, Taiwan Tel. +886 2 2134 2886, Fax. +886 2 2134 2874

Thailand: PHILIPS ELECTRONICS (THAILAND) Ltd.,
209/2 Sanpavuth-Bangna Road Prakanong, BANGKOK 10260,
Tel. +66 2 745 4090, Fax. +66 2 398 0793

Turkey: Yukari Dudullu, Org. San. Blg., 2.Cad. Nr. 28 81260 Umraniye,
ISTANBUL, Tel. +90 216 522 1500, Fax. +90 216 522 1813

Ukraine: PHILIPS UKRAINE, 4 Patrice Lumumba str., Building B, Floor 7,
252042 KIEV, Tel. +380 44 264 2776, Fax. +380 44 268 0461

United Kingdom: Philips Semiconductors Ltd., 276 Bath Road, Hayes,
MIDDLESEX UB3 5BX, Tel. +44 208 730 5000, Fax. +44 208 754 8421

United States: 811 East Arques Avenue, SUNNYVALE, CA 94088-3409,
Tel. +1 800 234 7381, Fax. +1 800 943 0087

Uruguay: see South America

Vietnam: see Singapore

Yugoslavia: PHILIPS, Trg N. Pasica 5/v, 11000 BEOGRAD,
Tel. +381 11 3341 299, Fax.+381 11 3342 553

For all other countries apply to: Philips Semiconductors,
International Marketing & Sales Communications, Building BE-p, P.O. Box 218,
5600 MD EINDHOVEN, The Netherlands, Fax. +31 40 27 24825

Internet: <http://www.semiconductors.philips.com>

© Philips Electronics N.V. 2000

SCA 69

All rights are reserved. Reproduction in whole or in part is prohibited without the prior written consent of the copyright owner.

The information presented in this document does not form part of any quotation or contract, is believed to be accurate and reliable and may be changed without notice. No liability will be accepted by the publisher for any consequence of its use. Publication thereof does not convey nor imply any license under patent- or other industrial or intellectual property rights.

Printed in The Netherlands

753503/25/01/pp44

Date of release: 2000 Mar 29

Document order number: 9397 750 06651

Let's make things better.

Philips
Semiconductors



PHILIPS