

FEATURES

- > 3.2Gbps operation
- Low noise CML Data Outputs
- Chatter-Free LOS generation
- Open Collector TTL LOS output
- TTL /EN Input
- Differential PECL inputs for data
- Single 3.3V or 5V power supply
- Designed for use with SY88922V and SY88905
- Available in a tiny 10-pin (3mm) MSOP

PIN CONFIGURATION

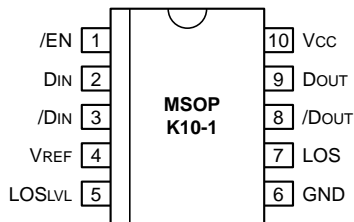

APPLICATIONS

- 1.25Gbps and 2.1Gbps Gigabit Ethernet
- 531Mbps, 1062Mbps and 2.5Gbps SONET/SDH Fibre Channel
- 622Mbps
- Gigabit interface converter (GBIC)
- Small Form Factor Transceivers
- Parallel 10G Ethernet

DESCRIPTION

The SY88993AV limiting post amplifier with its high and wide bandwidth is ideal for use as a post amplifier in fiber-optic receivers with data rates up to 3.2Gbps. Signals as small as 4mVp-p can be amplified to drive devices with CML inputs or AC coupled PECL inputs. The SY88993AV generates a chatter-free Loss of Signal (LOS) open collector TTL output.

The SY88993AV incorporates a programmable level detect function to identify when the input signal has been lost. This information can be fed back to the /EN input of the device to maintain stability under loss of signal conditions. Using LOS_{LVL} pin the sensitivity of the level detect can be adjusted. The LOS_{LVL} voltage can be set by connecting a resistor divider between V_{CC} and V_{REF}, Figure 3.

BLOCK DIAGRAM

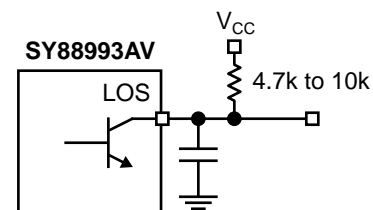
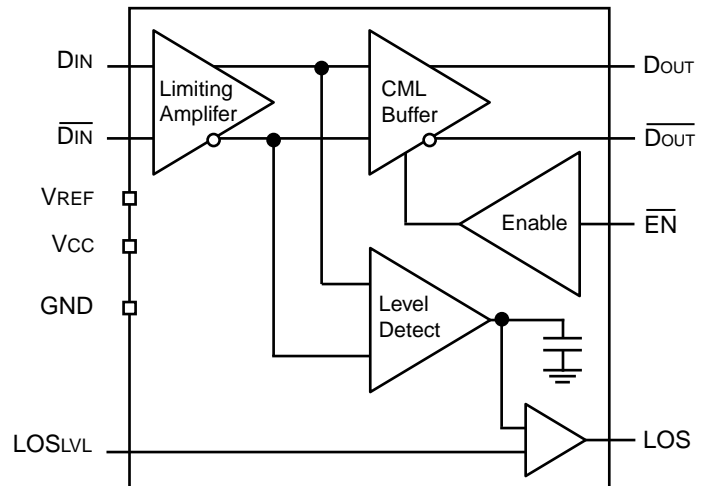

PIN NAMES

Pin	Type	Function
D _{IN}	Data Input	Data Input
/D _{IN}	Data Input	Inverting Data Input
LOS _{LVL}	Input	Loss of Signal Level Set
/EN	TTL Input	Output Enable (Active Low)
LOS	TTL Output (Open Collector)	Loss of Signal Indicator (Active High)
GND	Ground	Ground
D _{OUT}	CML Output	Data Output
/D _{OUT}	CML Output	Inverting Data Output
V _{CC}	Power Supply	Positive Power Supply
V _{REF}	Output	Reference Voltage Output for LOS Level Set (see Fig. 3)

GENERAL DESCRIPTION**General**

The SY88993AV is an integrated limiting amplifier intended for high-frequency fiber-optic applications. The circuit connects to typical transimpedance amplifiers found within a fiber-optics link. The linear signal output from a transimpedance amplifier can contain significant amounts of noise, and may vary in amplitude over time. The SY88993AV limiting amplifier quantizes the signal and outputs a voltage-limited waveform.

The /EN pin allows the user to disable the output signal without removing the input signal.

ABSOLUTE MAXIMUM RATINGS⁽¹⁾

Symbol	Rating	Value	Unit
V _{CC}	Power Supply Voltage	0 to +7.0	V
D _{IN} , /D _{IN}	Input Voltage	0 to V _{CC}	V
T _A	Operating Temperature Range	-40 to +85	°C
T _{store}	Storage Temperature Range	-55 to +125	°C

NOTE:

1. Permanent device damage may occur if ABSOLUTE MAXIMUM RATINGS are exceeded. This is a stress rating only and functional operation is not implied at conditions other than those detailed in the operational sections of this data sheet. Exposure to ABSOLUTE MAXIMUM RATING conditions for extended periods may affect device reliability.

DC ELECTRICAL CHARACTERISTICS
 $V_{CC} = +3.3V \pm 10\%$ or $+5V \pm 10\%$, $R_{LOAD} = 50\Omega$ to V_{CC}

Symbol	Parameter	TA = -40°C		TA = 0°C		TA = +25°C			TA = +85°C		Unit	
		Min.	Max.	Min.	Max.	Min.	Typ.	Max.	Min.	Max.		
I _{CC}	Power Supply Current ⁽¹⁾	5.0V	—	55	—	55	—	43	55	—	65	mA
		3.3V	—	50	—	50	—	40	50	—	60	mA
I _{IL}	/EN Input LOW Current	-0.3 ⁽⁴⁾	—	-0.3 ⁽⁴⁾	—	-0.3 ⁽⁴⁾	—	—	—	-0.3 ⁽⁴⁾	—	mA
I _{IH}	/EN Input HIGH Current	—	20 ⁽⁵⁾	—	20 ⁽⁵⁾	—	—	20 ⁽⁵⁾	—	20 ⁽⁵⁾	—	μA
		—	100 ⁽⁶⁾	—	100 ⁽⁶⁾	—	—	100 ⁽⁶⁾	—	100 ⁽⁶⁾	—	μA
I _{OH}	LOS Output Leakage ⁽²⁾	—	100	—	100	—	—	100	—	100	—	μA
V _{OFFSET}	Differential Output Offset	—	±80	—	±80	—	±9	±80	—	±80	—	mV
V _{CMR}	Common Mode Range	GND±2	V _{CC} -0.2	GND±2	V _{CC} -0.2	GND±2	—	V _{CC} -0.2	GND±2	V _{CC} -0.2	—	V
LOS _{LVL}	LOS _{LVL} Level	V _{REF}	V _{CC}	V _{REF}	V _{CC}	V _{REF}	—	V _{CC}	V _{REF}	V _{CC}	—	V
V _{OL}	LOS Output Low Level ⁽³⁾	—	0.5	—	0.5	—	—	0.5	—	0.5	—	V
V _{REF}	Reference Voltage	V _{CC} -1.38	V _{CC} -1.26	V _{CC} -1.38	V _{CC} -1.26	V _{CC} -1.38	V _{CC} -1.32	V _{CC} -1.26	V _{CC} -1.38	V _{CC} -1.26	—	V
V _{IH}	/EN Input HIGH Voltage	2.0	—	2.0	—	2.0	—	—	2.0	—	—	V
V _{IL}	/EN Input LOW Voltage	—	—	0.8	—	0.8	—	—	0.8	—	—	V

NOTES:

1. No output load. $V_{CC} = 5V \pm 10\%$ or $3.3V \pm 10\%$
2. $V_{OH} = 5.5V$.
3. $I_{OL} = +2mA$.
4. $V_{IN} = 0.5V$
5. $V_{IN} = 2.7V$
6. $V_{IN} = V_{CC}$

AC ELECTRICAL CHARACTERISTICS

$V_{CC} = +3.3V \pm 10\%$ or $+5V \pm 10\%$, $R_{LOAD} = 50\Omega$ to V_{CC}

Symbol	Parameter	TA = -40°C		TA = 0°C		TA = +25°C			TA = +85°C		Unit
		Min.	Max.	Min.	Max.	Min.	Typ.	Max.	Min.	Max.	
HYS	LOS Hysteresis	2	8	2	8	2	4.6	8	2	8	dB
PSRR	Power Supply ⁽¹⁾ Rejection Ratio	—	—	—	—	—	35	—	—	—	dB
t _{OFFL}	LOS Release Time ⁽²⁾ Minimum Input	—	0.5	—	0.5	—	0.1	0.5	—	0.5	μs
t _{OFFH}	LOS Release Time ⁽²⁾ Maximum Input	—	0.5	—	0.5	—	0.1	0.5	—	0.5	μs
t _{ONL}	LOS Assert Time ⁽²⁾	—	0.5	—	0.5	—	0.2	0.5	—	0.5	μs
t _r , t _f	Differential Output ⁽³⁾ Rise/Fall Time (20%-80%)	—	120	—	120	—	60	120	—	120	ps
V _{ID}	Input Voltage Range	4	1800	4	1800	4	—	1800	4	1800	mVp-p
V _{OD}	Differential Output Voltage Swing ⁽⁴⁾	—	600	—	600	—	800 ⁽⁵⁾	1200	600	—	mVp-p
V _{SR}	LOS Sensitivity Range	4	50	4	50	4	—	50	4	50	mVp-p

Output Spec (D_{OUT} and /D_{OUT})

V _{OH}	HIGH Level Output Voltage	V _{CC} -20	V _{CC}	V _{CC} -20	V _{CC}	V _{CC} -20	V _{CC} -5	V _{CC}	V _{CC} -20	V _{CC}	mV
V _{OL}	LOW Level Output ⁽⁶⁾ β	—	V _{CC} -300	—	V _{CC} -300	—	V _{CC} -400	V _{CC} -300	—	V _{CC} -300	mV
Z _O	Single-Ended Output ⁽⁷⁾ Impedance	40	60	40	60	40	50	60	40	60	Ω

Input Spec (D_{IN} and /D_{IN})

A _{V(Diff)}	Differential Voltage Gain	—	—	—	—	—	39	—	—	—	dB
B _{-3dB}	3dB Bandwidth	—	—	—	—	—	2.5	—	—	—	GHz
S ₂₁	Single-Ended Small Signal-Gain	26	—	26	—	26	33	—	26	—	dB

NOTES:

1. Input referred noise = RMS output noise/low frequency gain. Input referred, 55MHz.
2. Input is a 200MHz square wave, t_r < 300ps, 1.8Vp-p.
3. With input signal V_{ID} > 50mVp-p with 50Ω load.
4. Input is a 200MHz square wave, t_r < 300ps, 50Ω load.
5. V_{ID} > 5mVp-p.
6. Output levels are based on 50Ω impedance. If the load impedance is different, the output level will be changed.
7. See output structure.

PERFORMANCE CURVE

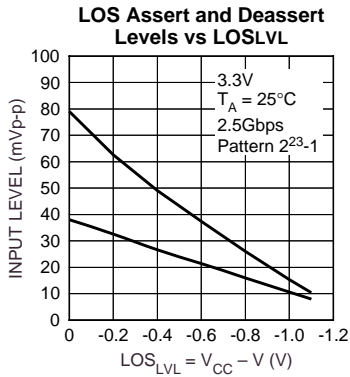

Figure 4.

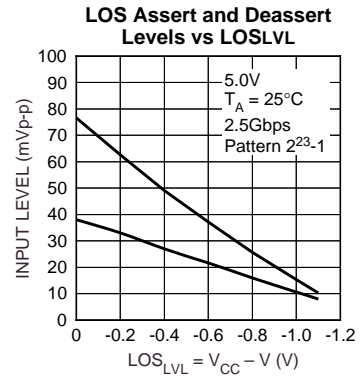

Figure 5.

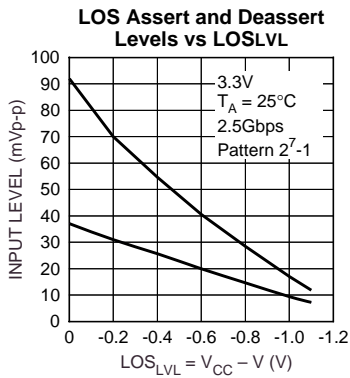

Figure 6.

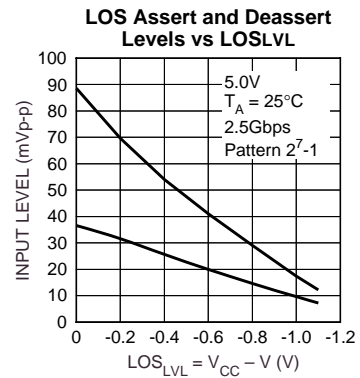

Figure 7.

APPLICATION NOTE

Output Termination

The SY88993AV outputs must be terminated with a 50Ω load to VCC.

Layout and PCB Design

Since the SY88993AV is a high-frequency component, performance can largely be determined by board layout and design. A common problem with high-gain amplifiers is feedback from the large swing outputs to the input via power supply.

The SY88993AV ground pin should be connected to the circuit board ground. Use multiple PCB vias close to the part to connect to ground. Avoid long, inductive runs which can degrade performance.

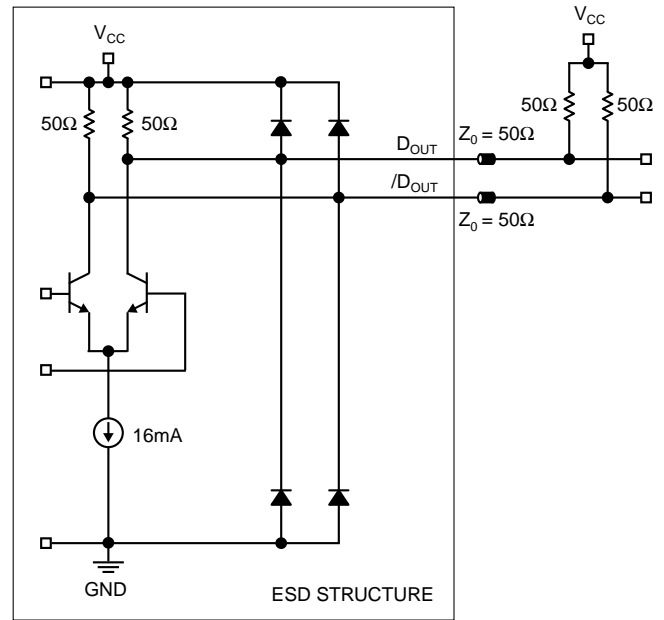

Figure 2. Differential Output Configuration

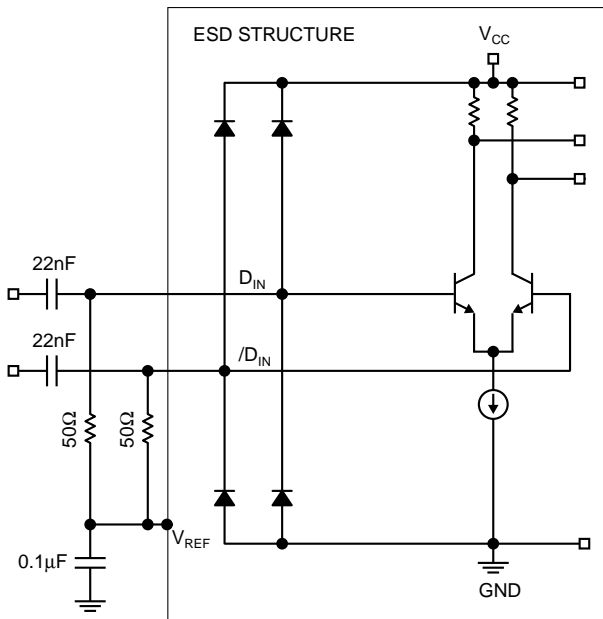
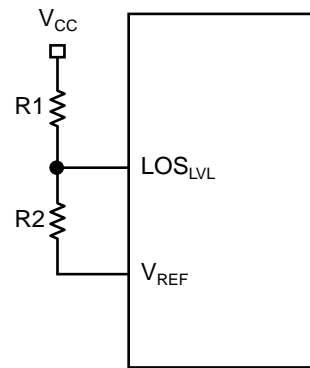

Figure 1. Differential Input Configuration



NOTES:

1. Resistor Divider = $R2 / (R1 + R2)$
2. $R1 + R2 \geq 5k\Omega$

Figure 3. LOS_{LVL} Circuit

PRODUCT ORDERING CODE

Ordering Code	Package Type	Operating Range
SY88993AVKC	K10-1	Commercial

APPLICATION EXAMPLE FOR 3-CHIP SET SOLUTION

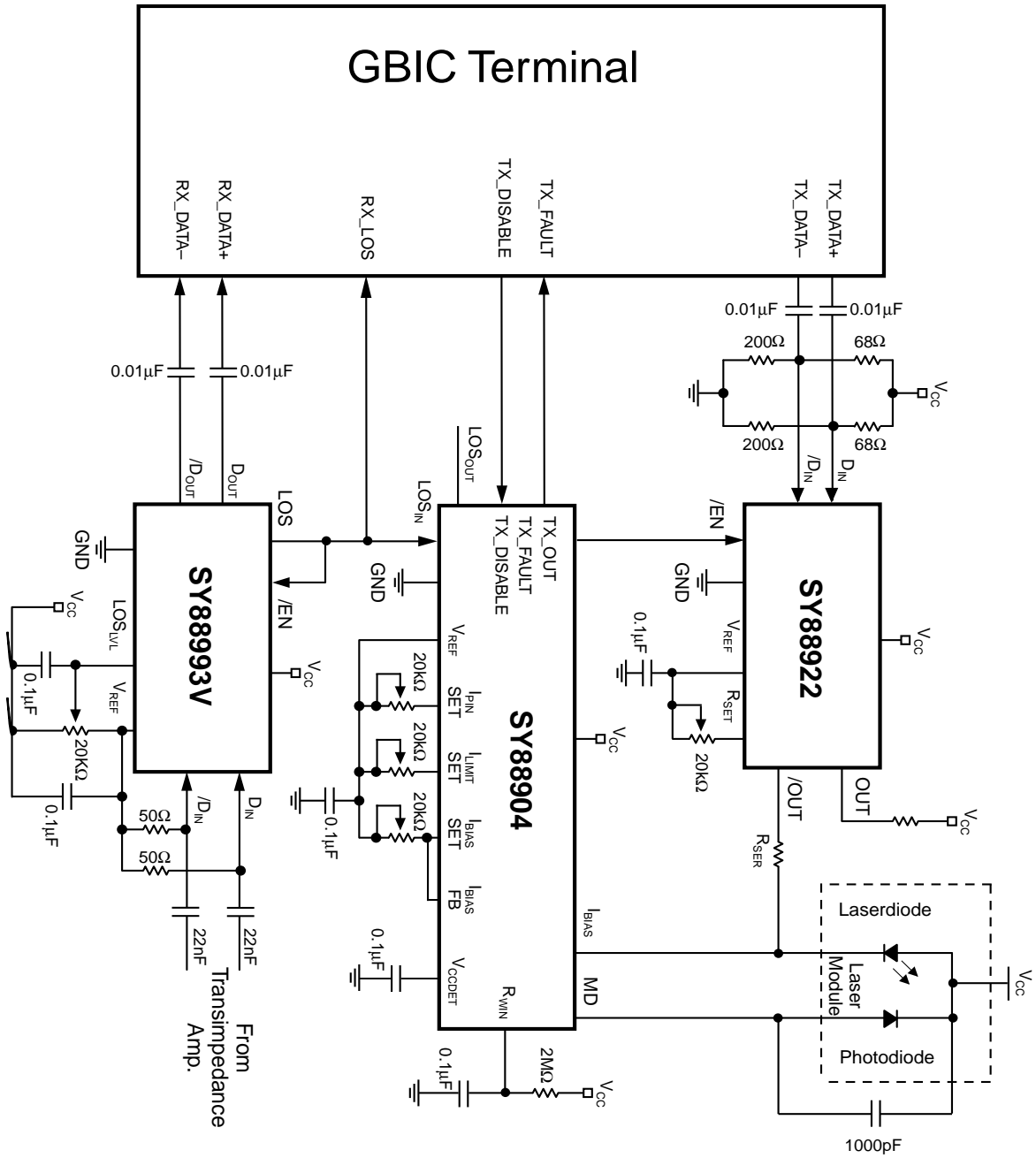

10 LEAD MSOP (K10-1)

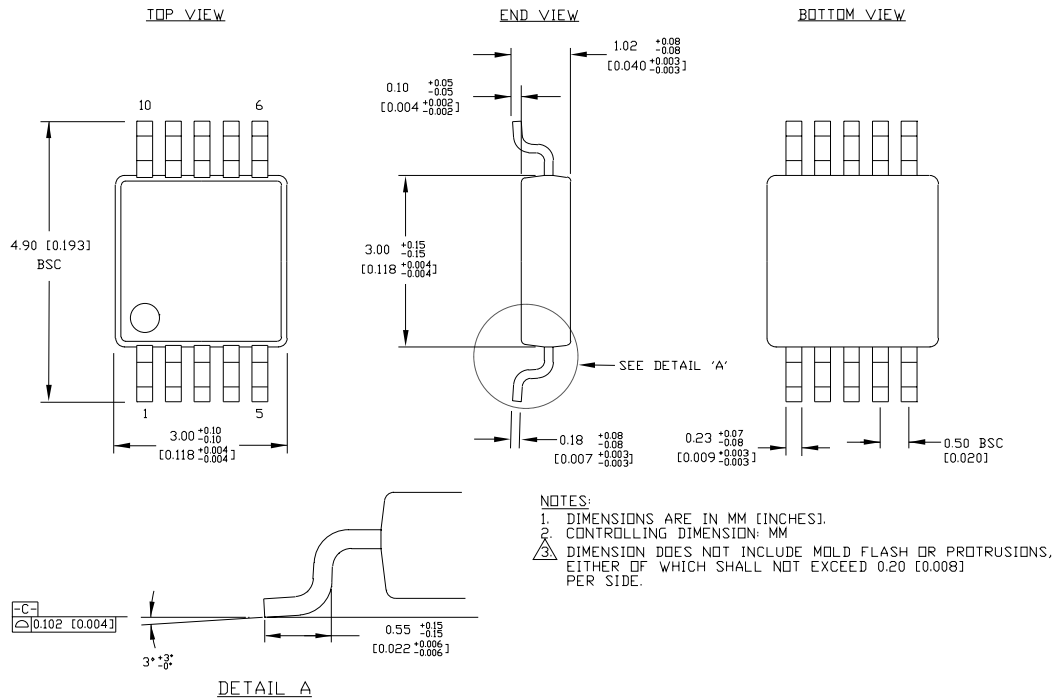

Rev. 00

MICREL-SYNERGY 3250 SCOTT BOULEVARD SANTA CLARA CA 95054 USA

TEL + 1 (408) 980-9191 FAX + 1 (408) 914-7878 WEB <http://www.micrel.com>

This information is believed to be accurate and reliable, however no responsibility is assumed by Micrel for its use nor for any infringement of patents or other rights of third parties resulting from its use. No license is granted by implication or otherwise under any patent or patent right of Micrel Inc.

© 2000 Micrel Incorporated
