

3-INPUT/2-INPUT VIDEO SWITCH

■ GENERAL DESCRIPTION

The NJM2513 is a switching IC for switching over from one audio or video input signal to another. Internalizing 3 input-1 output, and 2 input-1 output and then each set can be operated independently. Side of 2 input-1 output are "Clamp type", and they can be operated while setting DC level fixed in position of the video signal. It is a higher efficiency video switch, featuring the operating voltage 4.75 to 13V, the frequency feature 10MHz, and then the Crosstalk 75dB (at 4.43MHz).

■ PACKAGE OUTLINE

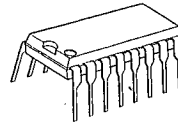

NJM2513D

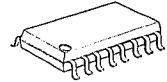

NJM2513M

■ FEATURES

- Operating Voltage (+4.75V ~ +13V)
- 3 Input-1 Output/2 Input-1 output
- Crosstalk 75dB(at 4.43MHz)
- Wide Bandwidth Frequency 10MHz(2V_{P-P} Input)
- Package Outline DIP16, DMP16
- Bipolar Technology

■ RECOMMENDED OPERATING CONDITION

- Operating Voltage V⁺ 4.75~13.0V

■ APPLICATIONS

- VCR, Video Camera, AV-TV, Video Disk Player.

■ BLOCK DIAGRAM

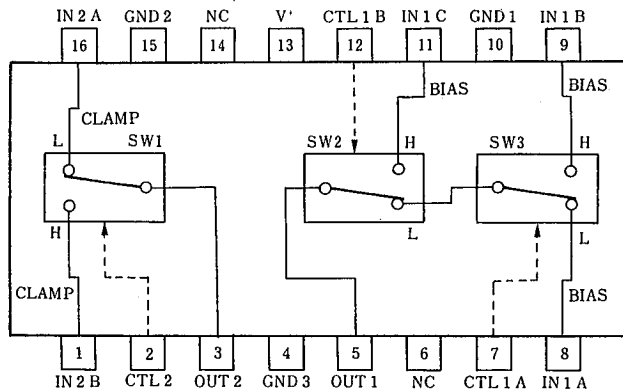

NJM2513D
NJM2513M

■ MAXIMUM RATINGS

($T_a=25^\circ\text{C}$)

PARAMETER	SYMBOL	RATINGS	UNIT
Supply Voltage	V^*	14	V
Power Dissipation	P_d	(DIP16) 700 (DMP16) 350	mW
Operating Temperature Range	T_{opr}	$-40 \sim +85$	$^\circ\text{C}$
Storage Temperature Range	T_{stg}	$-40 \sim +125$	$^\circ\text{C}$

■ ELECTRICAL CHARACTERISTICS

($V^*=5\text{V}$, $T_a=25^\circ\text{C}$)

PARAMETER	SYMBOL	TEST CONDITION	MIN.	TYP.	MAX.	UNIT
Operating Current (1)	I_{cc1}	$V^*=5\text{V}$ (Note1)	6.7	9.7	12.7	mA
Operating Current (2)	I_{cc2}	$V^*=9\text{V}$ (Note1)	8.6	12.3	16.0	mA
Voltage Gain	G_v	$V_i = 100\text{kHz}$, $2V_{p-p}$, V_o/V_i	-0.6	-0.1	+0.4	dB
Frequency Gain	G_F	$V_i = 2V_{p-p}$, $V_o(10\text{MHz})/V_o(100\text{kHz})$	-1.0	0	+1.0	dB
Differential Gain	DG	$V_i = 2V_{p-p}$, Standard Staircase Signal	—	0.3	—	%
Differential Phase	DP	$V_i = 2V_{p-p}$, Standard Staircase Signal	—	0.3	—	deg
OutPut offset Voltage (1)	V_{os1}	(Note2)	-15	0	+15	mV
OutPut offset Voltage (2)	V_{os2}	(Note3)	-25	0	+25	mV
Crosstalk	CT	$V_i = 2V_{p-p}$, 4.43MHz, V_o/V_i	—	-75	—	dB
Switch Change Over Voltage	V_{cH}	All inside Switches ON	2.5	—	—	V
Switch Change Over Voltage	V_{cL}	All inside Switches OFF	—	—	1.0	V

(Note1) $S1=S2=S3=S4=S5=S6=S7=1$

(Note2) $S1=S2=S3=S4=S5=1$, $S8=2$, $S7=1$, $S6=1 \rightarrow 2$ Measure the output DC voltage difference

(Note3) $S1=S2=S3=S4=S5=1$, $S8=1$, $S7=1$, $S6=1 \rightarrow 2$ ($S6=1$, $S7=1 \rightarrow 2$) Measure the output DC voltage difference

■ TEST CIRCUIT

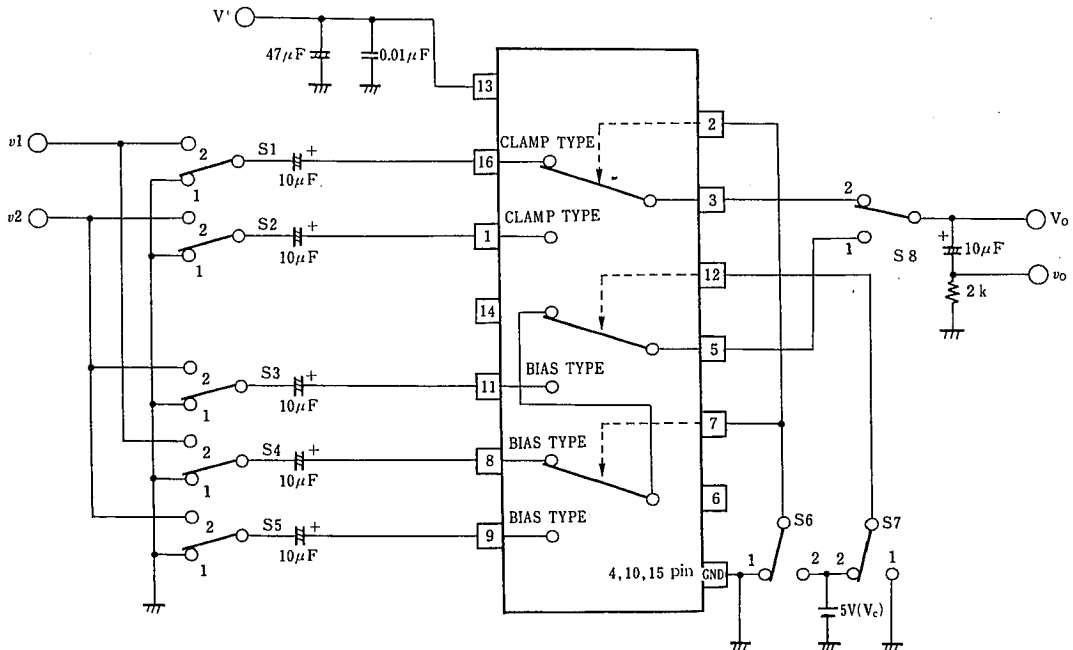

This IC requires $1\text{M}\Omega$ resistance between INPUT and GND pin for clamp type input since the minute current causes an unstable pin voltage.

■ TERMINAL EXPLANATION

PIN NO.	PIN NAME	VOLTAGE	INSIDE EQUIVALENT CIRCUIT
8 9 11	IN 1 A IN 1 B IN 1 C (Input)	2.5V $\left(\frac{1}{2}V^+\right)$	
16 1	IN 2 A IN 2 B (Input)	1.5V $\left(\frac{3}{10}V^+\right)$	
7 12 2	CTL 1 A CTL 1 B CTL 2 (Switching)		
5	OUT 1 (Output)	1.8V $\left(\frac{1}{2}V^+ - 0.7\right)$	
3	OUT 2 (Output)	0.8V $\left(\frac{3}{10}V^+ - 0.7\right)$	
13	V+	5V	
15 4 10	GND 1 GND 2 GND 3		

5

MEMO

[CAUTION]

The specifications on this databook are only given for information, without any guarantee as regards either mistakes or omissions. The application circuits in this databook are described only to show representative usages of the product and not intended for the guarantee or permission of any right including the industrial rights.