

FEATURES

- On-Chip and Remote Temperature Sensing
- Offset Registers for System Calibration
- 0.125°C Resolution/1°C Accuracy on Remote Channel
- 1°C Resolution/3°C Accuracy on Local Channel
- Fast (Up to 64 Measurements per Second)
- 2-Wire SMBus Serial Interface
- Supports SMBus Alert
- Programmable Over/Under Temperature Limits
- Programmable Fault Queue
- Over-Temperature Fail-Safe $\overline{\text{THERM}}$ Output
- Programmable $\overline{\text{THERM}}$ Limits
- Programmable $\overline{\text{THERM}}$ Hysteresis
- 170 μA Operating Current
- 5.5 μA Standby Current
- 3 V to 5.5 V Supply
- Small 8-Lead SO and Micro_SO Package

APPLICATIONS

- Desktop Computers
- Notebook Computers
- Smart Batteries
- Industrial Controllers
- Telecomms Equipment
- Instrumentation
- Embedded Systems

PRODUCT DESCRIPTION

The ADM1032 is a dual-channel digital thermometer and under/over temperature alarm, intended for use in personal computers and thermal management systems. The higher 1°C accuracy offered allows systems designers to safely reduce temperature guardbanding and increase system performance. The device can measure the temperature of a microprocessor using a diode-connected NPN or PNP transistor, which may be provided on-chip or can be a low-cost discrete device such as the 2N3906. A novel measurement technique cancels out the absolute value of the transistor's base emitter voltage, so that no calibration is required. The second measurement channel measures the output of an on-chip temperature sensor, to monitor the temperature of the device and its environment.

The ADM1032 communicates over a two-wire serial interface compatible with System Management Bus (SMBus) standards. Under and over temperature limits can be programmed into the device over the serial bus, and an $\overline{\text{ALERT}}$ output signals when the on-chip or remote temperature measurement is out of range. This output can be used as an interrupt, or as an SMBus alert. The $\overline{\text{THERM}}$ output is a comparator output that allows CPU clock throttling or on/off control of a cooling fan.

FUNCTIONAL BLOCK DIAGRAM

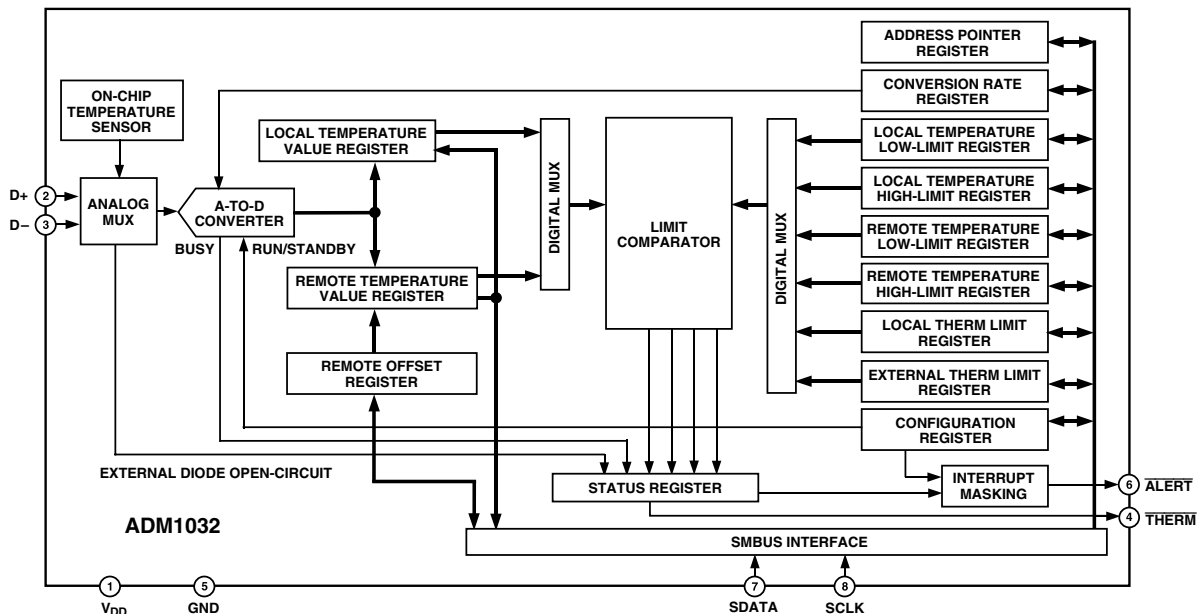

Pentium is a registered trademark of Intel Corporation.

*Patents 5,982,221, 6,097,239, 6,133,753, 6,169,442, 5,867,012.

REV. 0

Information furnished by Analog Devices is believed to be accurate and reliable. However, no responsibility is assumed by Analog Devices for its use, nor for any infringements of patents or other rights of third parties that may result from its use. No license is granted by implication or otherwise under any patent or patent rights of Analog Devices.

ADM1032—SPECIFICATIONS ($T_A = T_{MIN}$ to T_{MAX} , $V_{DD} = V_{MIN}$ to V_{MAX} , unless otherwise noted.)

Parameter	Min	Typ	Max	Unit	Test Conditions/Comments
POWER SUPPLY					
Supply Voltage, V_{DD}	3.0	3.30	5.5	V	
Average Operating Supply Current, I_{CC}		170	215	μ A	0.0625 Conversions/Sec Rate ¹
		5.5	10	μ A	Standby Mode
Undervoltage Lockout Threshold	2.35	2.55	2.8	V	V_{DD} Input, Disables ADC, Rising Edge
Power-On Reset Threshold	1		2.4	V	
TEMPERATURE-TO-DIGITAL CONVERTER					
Local Sensor Accuracy		± 1	± 3	$^{\circ}$ C	$0 \leq T_A \leq 100^{\circ}$ C, $V_{CC} = 3$ V to 3.6 V
Resolution		1		$^{\circ}$ C	
Remote Diode Sensor Accuracy			± 1	$^{\circ}$ C	60° C $\leq T_D \leq 100^{\circ}$ C, $V_{CC} = 3$ V to 3.6 V
			± 3	$^{\circ}$ C	0° C $\leq T_D \leq 120^{\circ}$ C
Resolution		0.125		$^{\circ}$ C	
Remote Sensor Source Current		230		μ A	High Level, Note 2
		13		μ A	Low Level, Note 2
Conversion Time	35.7		142.8	ms	From Stop Bit to Conversion Complete (Both Channels) One-Shot Mode with Averaging Switched On
	5.7		22.8	ms	One-Shot Mode with Averaging Off (i.e., Conversion Rate = 32 or 64 Conversions per Second)
OPEN-DRAIN DIGITAL OUTPUTS (THERM, ALERT)					
Output Low Voltage, V_{OL}			0.4	V	$I_{OUT} = -6.0$ mA ²
High Level Output Leakage Current, I_{OH}		0.1	1	μ A	$V_{OUT} = V_{DD}$ ²
SMBus INTERFACE²					
Logic Input High Voltage, V_{IH}	2.1			V	$V_{DD} = 3$ V to 5.5 V
SCLK, SDATA					
Logic Input Low Voltage, V_{IL}			0.8	V	$V_{DD} = 3$ V to 5.5 V
Hysteresis		500		mV	
SCLK, SDATA					
SMBus Output Low Sink Current	6			mA	SDATA Forced to 0.6 V
ALERT Output Low Sink Current	1			mA	ALERT Forced to 0.4 V
Logic Input Current, I_{IH} , I_{IL}	-1		+1	μ A	
SMBus Input Capacitance, SCLK, SDATA		5		pF	
SMBus Clock Frequency			100	kHz	
SMBus Timeout		25	64	ms	Note 3
SMBus Clock Low Time, t_{LOW}	4.7			μ s	t_{LOW} between 10% Points
SMBus Clock High Time, t_{HIGH}	4			μ s	t_{HIGH} between 90% Points
SMBus Start Condition Setup Time, $t_{SU:STA}$	4.7			μ s	
SMBus Start Condition Hold Time, $t_{HD:STA}$	4			μ s	Time from 10% of SDATA to 90% of SCLK
SMBus Stop Condition Setup Time, $t_{SU:STO}$	4			μ s	Time from 90% of SCLK to 10% of SDATA
SMBus Data Valid to SCLK Rising Edge Time, $t_{SU:DAT}$	250			ns	Time for 10% or 90% of SDATA to 10% of SCLK
SMBus Data Hold Time, $t_{HD:DAT}$	300			μ s	
SMBus Bus Free Time, t_{BUF}	4.7			μ s	Between Start/Stop Condition
SCLK Falling Edge to SDATA Valid Time, $t_{VD, DAT}$			1	μ s	Master Clocking in Data
SCLK, SDATA Rise Time, t_R			1	μ s	
SCLK, SDATA Fall Time, t_F			300	ns	

NOTES

¹See Table VI for information on other conversion rates.

²Guaranteed by Design, not production tested.

³The SMBus timeout is a programmable feature. By default it is not enabled. Details on how to enable it are available in the SMBus section of this data sheet.

Specifications subject to change without notice.

ABSOLUTE MAXIMUM RATINGS*

Positive Supply Voltage (V_{DD}) to GND	-0.3 V, +5.5 V
D+	-0.3 V to $V_{DD} + 0.3$ V
D-	-0.3 V to +0.6 V
SCLK, SDATA, $\overline{\text{ALERT}}$	-0.3 V to +5.5 V
$\overline{\text{THERM}}$	-0.3 V to $V_{DD} + 0.3$ V
Input Current, SDATA, $\overline{\text{THERM}}$	-1, +50 mA
Input Current, D-	± 1 mA
ESD Rating, All Pins (Human Body Model)	>1000 V
Maximum Junction Temperature (T_J max)	150°C
Storage Temperature Range	-65°C to +150°C
IR Reflow Peak Temp	220°C
Lead Temp (Soldering 10 sec)	300°C

*Stresses above those listed under Absolute Maximum Ratings may cause permanent damage to the device. This is a stress rating only; functional operation of the device at these or any other conditions above those indicated in the operational section of this specification is not implied. Exposure to absolute maximum rating conditions for extended periods may affect device reliability.

THERMAL CHARACTERISTICS

8-Lead SO Package	$\theta_{JA} = 121^\circ\text{C/W}$
8-Lead Micro_SO Package	$\theta_{JA} = 142^\circ\text{C/W}$

PIN CONFIGURATION

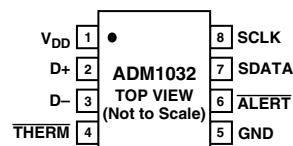

ORDERING GUIDE

Model	Temperature Range	Package Description	Package Option	Branding Information	SMBus Addr
ADM1032AR	0°C to 120°C	8-Lead SO Package	SO-8	1032AR	4C
ADM1032ARM	0°C to 120°C	8-Lead Micro_SO Package	RM-8	T2A	4C

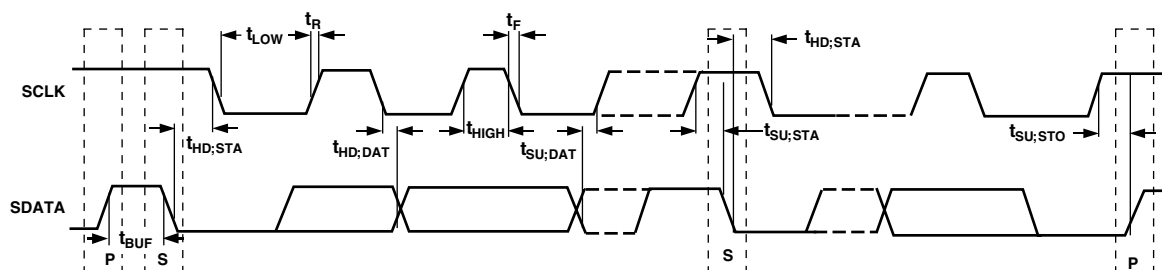
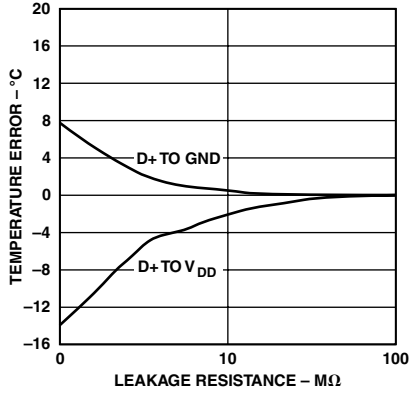

Figure 1. Diagram for Serial Bus Timing

PIN FUNCTION DESCRIPTIONS

Pin No.	Mnemonic	Description
1	V_{DD}	Positive Supply, 3 V to 5.5 V.
2	D+	Positive Connection to Remote Temperature Sensor.
3	D-	Negative Connection to Remote Temperature Sensor.
4	$\overline{\text{THERM}}$	Open-drain output that can be used to turn a fan on/off or throttle a CPU clock in the event of an over-temperature condition. Requires pull-up to V_{DD} .
5	GND	Supply Ground Connection
6	$\overline{\text{ALERT}}$	Open-Drain Logic Output Used as Interrupt or SMBus Alert.
7	SDATA	Logic Input/Output, SMBus Serial Data. Open-Drain Output. Requires pull-up resistor.
8	SCLK	Logic Input, SMBus Serial Clock. Requires pull-up resistor.

ADM1032—Typical Performance Characteristics



TPC 1. Temperature Error vs. Leakage Resistance

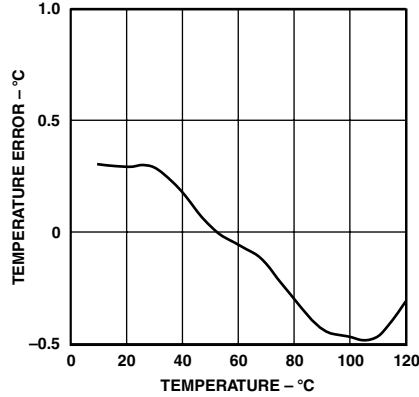

TPC 2. Temperature Error vs. Actual Temperature Using 2N3906

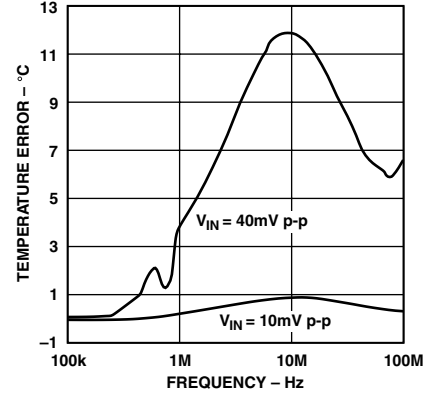

TPC 3. Temperature Error vs. Differential Mode Noise Frequency

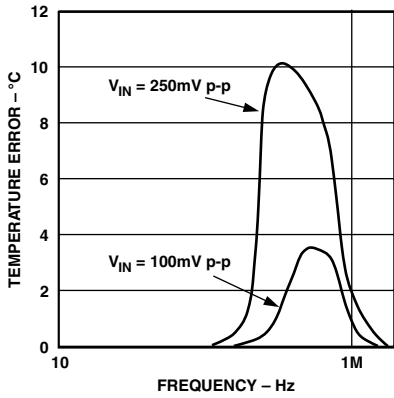

TPC 4. Temperature Error vs. Power Supply Noise Frequency

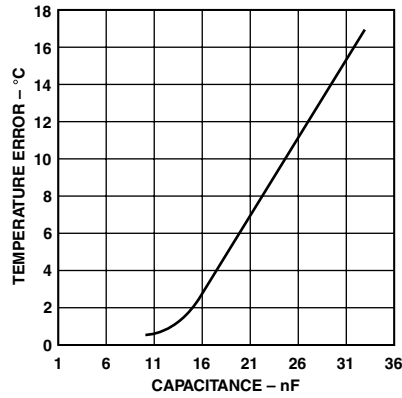

TPC 5. Temperature Error vs. Capacitance between D+ and D-

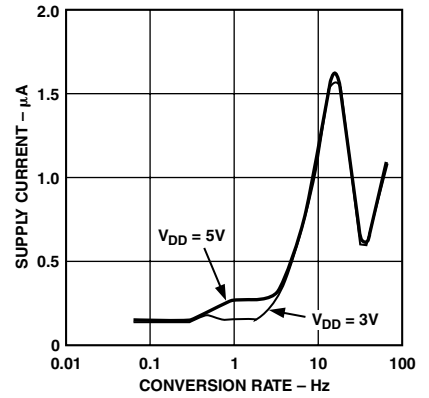

TPC 6. Operating Supply Current vs. Conversion Rate

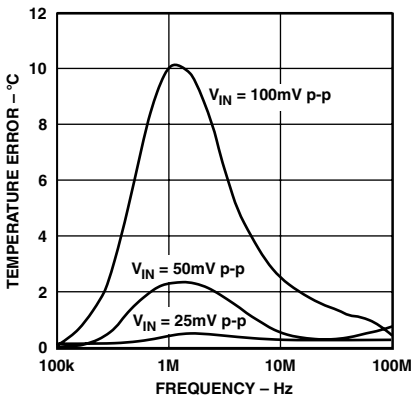

TPC 7. Temperature Error vs. Common-Mode Noise Frequency

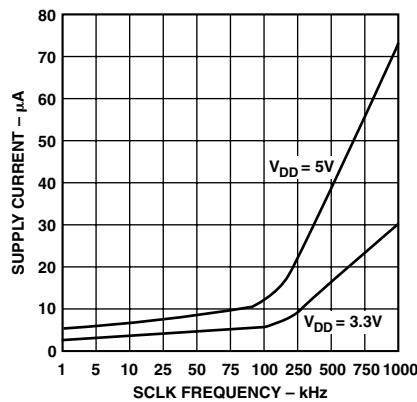

TPC 8. Standby Supply Current vs. Clock Frequency

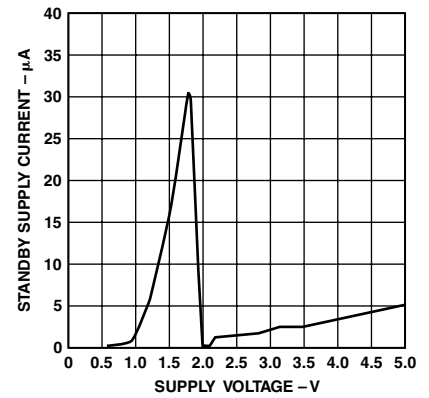

TPC 9. Standby Supply Current vs. Supply Voltage

FUNCTIONAL DESCRIPTION

The ADM1032 is a local and remote temperature sensor and over-temperature alarm. When the ADM1032 is operating normally, the on-board A-to-D converter operates in a free-running mode. The analog input multiplexer alternately selects either the on-chip temperature sensor to measure its local temperature, or the remote temperature sensor. These signals are digitized by the ADC and the results stored in the Local and Remote Temperature Value Registers.

The measurement results are compared with local and remote, high, low and $\overline{\text{THERM}}$ temperature limits, stored in nine on-chip registers. Out-of-limit comparisons generate flags that are stored in the Status Register, and one or more out-of-limit results will cause the $\overline{\text{ALERT}}$ output to pull low. Exceeding $\overline{\text{THERM}}$ temperature limits cause the $\overline{\text{THERM}}$ output to assert low.

The limit registers can be programmed, and the device controlled and configured, via the serial System Management Bus (SMBus). The contents of any register can also be read back via the SMBus.

Control and configuration functions consist of:

- Switching the device between normal operation and standby mode.
- Masking or enabling the $\overline{\text{ALERT}}$ output.
- Selecting the conversion rate.

MEASUREMENT METHOD

A simple method of measuring temperature is to exploit the negative temperature coefficient of a diode, or the base-emitter voltage of a transistor, operated at constant current. Unfortunately, this technique requires calibration to null out the effect of the absolute value of V_{BE} , which varies from device to device.

The technique used in the ADM1032 is to measure the change in V_{BE} when the device is operated at two different currents.

This is given by:

$$\Delta V_{BE} = (n_f) \frac{KT}{q} \times \ln(N)$$

where:

K is Boltzmann's constant (1.38×10^{-23}).

q is charge on the electron (1.6×10^{-19} Coulombs).

T is absolute temperature in Kelvins.

N is ratio of the two currents.

n_f is the ideality factor of the thermal diode.

The ADM1032 is trimmed for an ideality factor of 1.008.

Figure 2 shows the input signal conditioning used to measure the output of an external temperature sensor. This figure shows the external sensor as a substrate transistor, provided for temperature monitoring on some microprocessors, but it could equally well be a discrete transistor. If a discrete transistor is used, the collector will not be grounded, and should be linked to the base. To prevent ground noise interfering with the measurement, the more negative terminal of the sensor is not referenced to ground, but is biased above ground by an internal diode at the D- input. If the sensor is operating in a noisy environment, C1 may optionally be added as a noise filter. Its value is typically 2200 pF, but should be no more than 3000 pF. See the section on Layout Considerations for more information on C1.

To measure ΔV_{BE} , the sensor is switched between operating currents of I and $N \times I$. The resulting waveform is passed through a 65 kHz low-pass filter to remove noise, thence to a chopper-stabilized amplifier that performs the functions of amplification and rectification of the waveform to produce a dc voltage proportional to ΔV_{BE} . This voltage is measured by the ADC to give a temperature output in two's complement format. To further reduce the effects of noise, digital filtering is performed by averaging the results of 16 measurement cycles.

Signal conditioning and measurement of the internal temperature sensor is performed in a similar manner.

TEMPERATURE DATA FORMAT

One LSB of the ADC corresponds to 0.125°C , so the ADC can measure from 0°C to 127.875°C . The temperature data format is shown in Tables I and II.

The results of the local and remote temperature measurements are stored in the Local and Remote Temperature Value Registers, and are compared with limits programmed into the Local and Remote High and Low Limit Registers.

Table I. Temperature Data Format (Local Temperature and Remote Temperature High Byte)

Temperature	Digital Output
0°C	0 000 0000
1°C	0 000 0001
10°C	0 000 1010
25°C	0 001 1001
50°C	0 011 0010
75°C	0 100 1011
100°C	0 110 0100
125°C	0 111 1101
127°C	0 111 1111

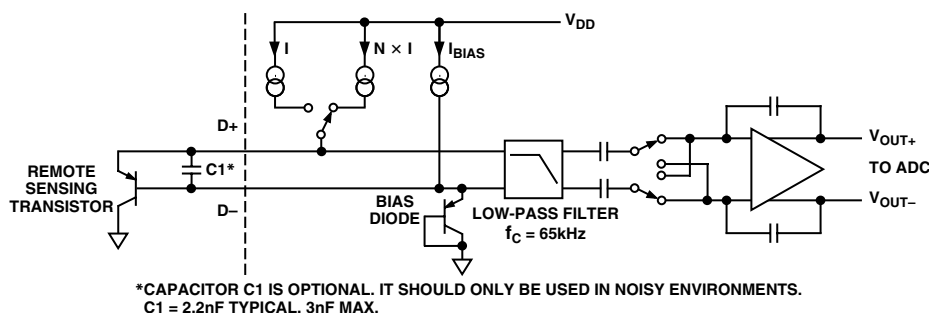

Figure 2. Input Signal Conditioning

ADM1032

Table II. Extended Temperature Resolution (Remote Temperature Low Byte)

Extended Resolution	Remote Temperature Low Byte
0.000°C	0 000 0000
0.125°C	0 010 0000
0.250°C	0 100 0000
0.375°C	0 110 0000
0.500°C	1 000 0000
0.625°C	1 010 0000
0.750°C	1 100 0000
0.875°C	1 110 0000

ADM1032 REGISTERS

The ADM1032 contains registers that are used to store the results of remote and local temperature measurements, high and low temperature limits, and to configure and control the device. A description of these registers follows, and further details are given in Tables III to VII.

Address Pointer Register

The Address Pointer Register itself does not have, or require, an address, as it is the register to which the first data byte of every Write operation is written automatically. This data byte is an address pointer that sets up one of the other registers for the second byte of the Write operation, or for a subsequent read operation.

The power-on default value of the Address Pointer Register is 00h, so if a read operation is performed immediately after power-on without first writing to the Address Pointer, the value of the local temperature will be returned, since its register address is 00h.

Value Registers

The ADM1032 has three registers to store the results of Local and Remote temperature measurements. These registers are written to by the ADC only and can be read over the SMBus.

Offset Register

Series resistance on the D+ and D- lines in processor packages and clock noise can introduce offset errors into the remote temperature measurement. To achieve the specified accuracy on this channel these offsets must be removed.

The offset value is stored as an 11-bit, two's complement value in registers 11h (high byte) and 12h (low byte, left justified).

The value of the offset is negative if the MSB of register 11h is 1 and it is positive if the MSB of register 12h is 0. The value is added to the measured value of remote temperature.

The offset register powers up with a default value of 0°C, and will have no effect if nothing is written to them.

Table III. Sample Offset Register Codes

Offset Value	11h	12h
-4°C	1 111 1100	0 000 0000
-1°C	1 111 1111	0 000 0000
-0.125°C	1 111 1111	1 110 0000
0°C	0 000 0000	0 000 0000
+0.125°C	0 000 0000	0 010 0000
+1°C	0 000 0001	0 000 0000
+4°C	0 000 0100	0 000 0000

Status Register

Bit 7 of the Status Register indicates that the ADC is busy converting when it is high. Bits 6 to 3, 1, and 0 are flags that indicate the results of the limit comparisons. Bit 2 is set when the remote sensor is open circuit.

If the local and/or remote temperature measurement is above the corresponding high temperature limit, or below or equal to, the corresponding low temperature limit, one or more of these flags will be set. These five flags (Bits 6 to 2) NOR'd together, so that if any of them is high, the $\overline{\text{ALERT}}$ interrupt latch will be set and the $\overline{\text{ALERT}}$ output will go low. Reading the Status Register will clear the five flag bits, provided the error conditions that caused the flags to be set have gone away. While a limit comparator is tripped due to a value register containing an out-of-limit measurement, or the sensor is open circuit, the corresponding flag bit cannot be reset. A flag bit can only be reset if the corresponding value register contains an in-limit measurement or the sensor is good.

The $\overline{\text{ALERT}}$ interrupt latch is not reset by reading the Status Register, but will be reset when the $\overline{\text{ALERT}}$ output has been serviced by the master reading the device address, provided the error condition has gone away and the Status Register flag bits have been reset.

When Flags 1 and 0 are set, the $\overline{\text{THERM}}$ output goes low to indicate that the temperature measurements are outside the programmed limits. $\overline{\text{THERM}}$ output does not need to be reset, unlike the $\overline{\text{ALERT}}$ output. Once the measurements are within the limits, the corresponding Status register bits are reset and the $\overline{\text{THERM}}$ output goes high.

Table IV. Status Register Bit Assignments

Bit	Name	Function
7	BUSY	1 When ADC Converting
6	LHIGH*	1 When Local High-Temp Limit Tripped
5	LLOW*	1 When Local Low-Temp Limit Tripped
4	RHIGH*	1 When Remote High-Temp Limit Tripped
3	RLOW*	1 When Remote Low-Temp Limit Tripped
2	OPEN*	1 When Remote Sensor Open-Circuit
1	RTHRM	1 When Remote Therm Limit Tripped
0	LTHRM	1 When Local Therm Limit Tripped

*These flags stay high until the status register is read or they are reset by POR.

Configuration Register

Two bits of the Configuration Register are used. If Bit 6 is 0, which is the power-on default, the device is in operating mode with the ADC converting. If Bit 6 is set to 1, the device is in standby mode and the ADC does not convert. The SMBus does, however, remain active in Standby Mode so values can be read from or written to the SMBus. The $\overline{\text{ALERT}}$ and $\overline{\text{THERM}}$ O/Ps are also active in Standby Mode.

Bit 7 of the configuration register is used to mask the alert output. If Bit 7 is 0, which is the power-on default, the output is enabled. If Bit 7 is set to 1, the output is disabled.

Table V. Configuration Register Bit Assignments

Bit	Name	Function	Power-On Default
7	MASK1	0 = $\overline{\text{ALERT}}$ Enabled 1 = $\overline{\text{ALERT}}$ Masked	0
6	RUN/STOP	0 = Run 1 = Standby	0
5–0		Reserved	0

Conversion Rate Register

The lowest four bits of this register are used to program the conversion rate by dividing the internal oscillator clock by 1, 2, 4, 8, 16, 32, 64, 128, 256, 512, or 1024 to give conversion times from 15.5 ms (code 0Ah) to 16 seconds (code 00h). This register can be written to and read back over the SMBus. The higher four bits of this register are unused and must be set to zero. Use of slower conversion times greatly reduces the device power consumption, as shown in Table VI.

Table VI. Conversion Rate Register Codes

Data	Conversion/sec	Average Supply Current mA Typ at $V_{DD} = 5.5\text{ V}$
00h	0.0625	0.17
01h	0.125	0.20
02h	0.25	0.21
03h	0.5	0.24
04h	1	0.29
05h	2	0.40
06h	4	0.61
07h	8	1.1
08h	16	1.9
09h	32	0.73
0Ah	64	1.23
0B to FFh	Reserved	

Limit Registers

The ADM1032 has nine Limit Registers to store local and remote, high, low, and $\overline{\text{THERM}}$ temperature limits. These registers can be written to and read back over the SMBus.

The high limit registers perform a $>$ comparison while the low limit registers perform a \leq comparison. For example, if the high limit register is programmed with 80°C, then measuring 81°C will result in an alarm condition. If the Low Limit Register is programmed with 0°C, measuring 0°C or lower will result in Alarm condition. Exceeding either the Local or Remote $\overline{\text{THERM}}$ limit asserts $\overline{\text{THERM}}$ low. A default hysteresis value of 10°C is provided, which applies to both channels. This hysteresis may be reprogrammed to any value after power up (Reg 0x21h).

One-Shot Register

The One-Shot Register is used to initiate a single conversion and comparison cycle when the ADM1032 is in standby mode, after which the device returns to standby. This is not a data register as such, and it is the write operation that causes the one-shot conversion. The data written to this address is irrelevant and is not stored. The conversion time on a single shot is 96 ms when the conversion rate is 16 conversions per second or less. At 32 conversions per second the conversion time is 15.3 ms. This is because averaging is disabled at the faster conversion rates (32 and 64 conversions per second).

Consecutive $\overline{\text{ALERT}}$ Register

This value written to this register determines how many out-of-limit measurements must occur before an $\overline{\text{ALERT}}$ is generated. The default value is that one out-of-limit measurement generates an $\overline{\text{ALERT}}$. The max value that can be chosen is 4. The purpose of this register is to allow the user to perform some filtering of the output. This is particularly useful at the faster two conversion rates where no averaging takes place.

Table VII.

Register Value	Number of “Out-of-Limit” Measurements Required
yxxx 000x	1
yxxx 001x	2
yxxx 011x	3
yxxx 111x	4

NOTES

x = Don't care bit.

y = SMBus timeout bit. Default = 0. See SMBus section for more information.

SERIAL BUS INTERFACE

Control of the ADM1032 is carried out via the serial bus. The ADM1032 is connected to this bus as a slave device, under the control of a master device.

There is a programmable SMBus timeout. When this is enabled the SMBus will timeout after typically 25 ms of no activity. However, this feature is not enabled by default. To enable it, set Bit 7 of the Consecutive Alert Register (Addr = 22h).

The ADM1032 supports Packet Error Checking (PEC) and its use is optional. It is triggered by supplying the extra clock for the PEC byte. The PEC byte is calculated using CRC-8. The Frame Check Sequence (FCS) conforms to CRC-8 by the polynomial:

$$C(x) = x^8 + x^2 + x^1 + 1$$

Consult SMBus 1.1 specification for more information (www.smbus.org).

ADDRESSING THE DEVICE

In general, every SMBus device has a 7-bit device address (except for some devices that have extended, 10-bit addresses). When the master device sends a device address over the bus, the slave device with that address will respond. The ADM1032 is available with one device address, which is Hex 4C (1001 100).

The serial bus protocol operates as follows:

1. The master initiates data transfer by establishing a START condition, defined as a high-to-low transition on the serial data line SDATA, while the serial clock line SCLK remains high. This indicates that an address/data stream will follow. All slave peripherals connected to the serial bus respond to the START condition, and shift in the next eight bits, consisting of a 7-bit address (MSB first) plus an $\overline{\text{R/W}}$ bit, which determines the direction of the data transfer, i.e., whether data will be written to or read from the slave device.

The peripheral whose address corresponds to the transmitted address responds by pulling the data line low during the low period before the ninth clock pulse, known as the Acknowledge Bit. All other devices on the bus now remain idle while the selected device waits for data to be read from or written

Table VIII. List of ADM1032 Registers

Read Address (Hex)	Write Address (Hex)	Name	Power-On Default
Not Applicable	Not Applicable	Address Pointer	Undefined
00	Not Applicable	Local Temperature Value	0000 0000 (00h)
01	Not Applicable	External Temperature Value High Byte	0000 0000 (00h)
02	Not Applicable	Status	Undefined
03	09	Configuration	0000 0000 (00h)
04	0A	Conversion Rate	0000 1000 (08h)
05	0B	Local Temperature High Limit	0101 0101 (55h) (85°C)
06	0C	Local Temperature Low Limit	0000 0000 (00h) (0°C)
07	0D	External Temperature High Limit High Byte	0101 0101 (55h) (85°C)
08	0E	External Temperature Low Limit High Byte	0000 0000 (00h) (0°C)
Not Applicable	0F	One-Shot	
10	Not Applicable	External Temperature Value Low Byte	0000 0000
11	11	External Temperature Offset High Byte	0000 0000
12	12	External Temperature Offset Low Byte	0000 0000
13	13	External Temperature High Limit Low Byte	0000 0000
14	14	External Temperature Low Limit Low Byte	0000 0000
19	19	External $\overline{\text{THERM}}$ Limit	0101 0101 (55h) (85°C)
20	20	Local $\overline{\text{THERM}}$ Limit	0101 0101 (55h) (85°C)
21	21	$\overline{\text{THERM}}$ Hysteresis	0000 1010 (0Ah) (10°C)
22	22	Consecutive ALERT	0000 0001 (01h)
FE	Not Applicable	Manufacturer ID	0100 0001 (41h)
FF	Not Applicable	Die Revision Code	Undefined

Writing to address 0F causes the ADM1032 to perform a single measurement. It is not a data register as such and it does not matter what data is written to it.

to it. If the $\overline{\text{R/W}}$ bit is a 0, the master will write to the slave device. If the $\overline{\text{R/W}}$ bit is a 1, the master will read from the slave device.

- Data is sent over the serial bus in sequences of nine clock pulses, eight bits of data followed by an Acknowledge Bit from the slave device. Transitions on the data line must occur during the low period of the clock signal and remain stable during the high period, as a low-to-high transition when the clock is high may be interpreted as a STOP signal. The number of data bytes that can be transmitted over the serial bus in a single Read or Write operation is limited only by what the master and slave devices can handle.
- When all data bytes have been read or written, stop conditions are established. In Write mode, the master will pull the data line high during the tenth clock pulse to assert a STOP condition. In Read mode, the master device will override the acknowledge bit by pulling the data line high during the low period before the ninth clock pulse. This is known as No Acknowledge. The master will then take the data line low during the low period before the tenth clock pulse, then high during the tenth clock pulse to assert a STOP condition.

Any number of bytes of data may be transferred over the serial bus in one operation, but it is not possible to mix read and write in one operation because the type of operation is determined at the beginning and cannot subsequently be changed without starting a new operation.

In the case of the ADM1032, write operations contain either one or two bytes, while read operations contain one byte, and perform the following functions:

To write data to one of the device data registers or read data from it, the Address Pointer Register must be set so that the correct data register is addressed, then data can be written into that register or read from it. The first byte of a write operation always contains a valid address that is stored in the Address Pointer Register. If data is to be written to the device, the write operation contains a second data byte that is written to the register selected by the address pointer register.

This is illustrated in Figure 3a. The device address is sent over the bus followed by $\overline{\text{R/W}}$ set to 0. This is followed by two data bytes. The first data byte is the address of the internal data register to be written to, which is stored in the Address Pointer Register. The second data byte is the data to be written to the internal data register.

When reading data from a register there are two possibilities:

- If the ADM1032's Address Pointer Register value is unknown or not the desired value, it is first necessary to set it to the correct value before data can be read from the desired data register. This is done by performing a write to the ADM1032 as before, but only the data byte containing the register read address is sent, as data is not to be written to the register. This is shown in Figure 3b.

A read operation is then performed consisting of the serial bus address, $\overline{\text{R/W}}$ bit set to 1, followed by the data byte read from the data register. This is shown in Figure 3c.

- If the Address Pointer Register is known to be already at the desired address, data can be read from the corresponding data register without first writing to the Address Pointer Register and Figure 3b can be omitted.

1. Although it is possible to read a data byte from a data register without first writing to the Address Pointer Register, if the Address Pointer Register is already at the correct value, it is not possible to write data to a register without writing to the Address Pointer Register, because the first data byte of a write is always written to the Address Pointer Register.
2. Don't forget that some of the ADM1032 registers have different addresses for read and write operations. The write address of a register must be written to the Address Pointer if data is to be written to that register, but it is not possible to read data from that address. The read address of a register must be written to the Address Pointer before data can be read from that register.

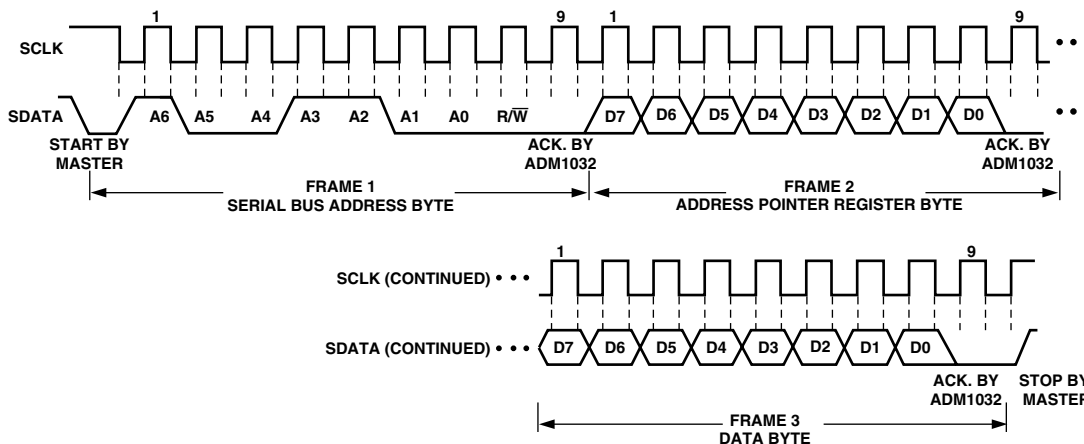

Figure 3a. Writing a Register Address to the Address Pointer Register, then Writing Data to the Selected Register

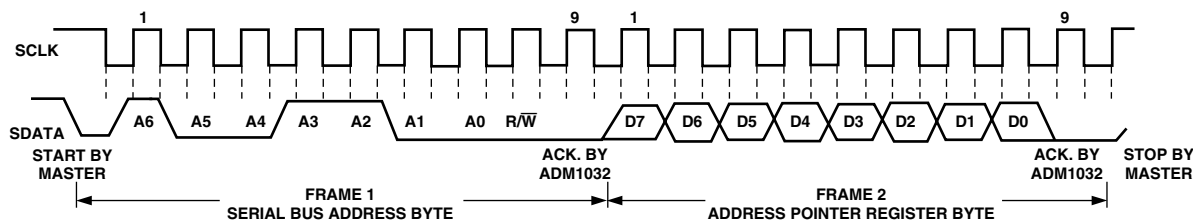

Figure 3b. Writing to the Address Pointer Register Only

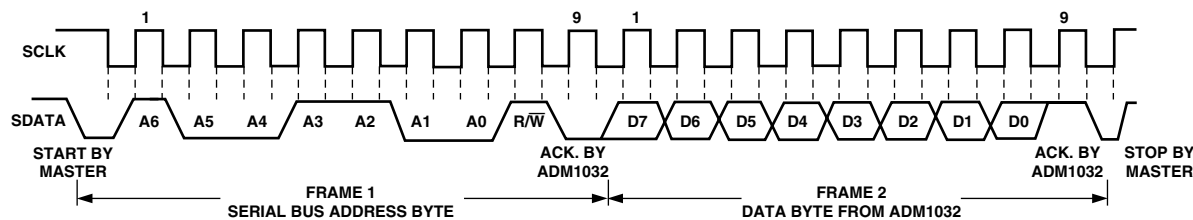

Figure 3c. Reading Data from a Previously Selected Register

ALERT OUTPUT

The $\overline{\text{ALERT}}$ output goes low whenever an out-of-limit measurement is detected, or if the remote temperature sensor is open-circuit. It is an open drain and requires a pull-up to V_{DD} . Several $\overline{\text{ALERT}}$ outputs can be wire-ORed together, so that the common line will go low if one or more of the $\overline{\text{ALERT}}$ outputs goes low.

The $\overline{\text{ALERT}}$ output can be used as an interrupt signal to a processor, or it may be used as an $\overline{\text{SMBALERT}}$. Slave devices on the SMBus can normally not signal to the master that they want to talk, but the $\overline{\text{SMBALERT}}$ function allows them to do so.

One or more $\overline{\text{ALERT}}$ outputs can be connected to a common $\overline{\text{SMBALERT}}$ line connected to the master. When the $\overline{\text{SMBALERT}}$ line is pulled low by one of the devices, the following procedure occurs as illustrated in Figure 4.

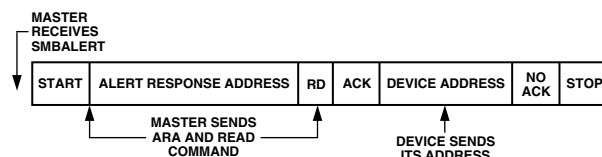

Figure 4. Use of $\overline{\text{SMBALERT}}$

ADM1032

1. $\overline{\text{SMBALERT}}$ pulled low.
2. Master initiates a read operation and sends the Alert Response Address (ARA = 0001 100). This is a general call address that must not be used as a specific device address.
3. The device whose $\overline{\text{ALERT}}$ output is low responds to the Alert Response Address and the master reads its device address. As the device address is seven bits, an LSB of '1' is added. The address of the device is now known and it can be interrogated in the usual way.
4. If more than one device's $\overline{\text{ALERT}}$ output is low, the one with the lowest device address, will have priority, in accordance with normal SMBus arbitration.
5. Once the ADM1032 has responded to the Alert Response Address, it will reset its $\overline{\text{ALERT}}$ output, provided that the error condition that caused the $\overline{\text{ALERT}}$ no longer exists. If the $\overline{\text{SMBALERT}}$ line remains low, the master will send ARA again, and so on until all devices whose $\overline{\text{ALERT}}$ outputs were low have responded.

LOW-POWER STANDBY MODE

The ADM1032 can be put into a low-power standby mode by setting bit 6 of the Configuration Register. When Bit 6 is low, the ADM1032 operates normally. When Bit 6 is high, the ADC is inhibited, and any conversion in progress is terminated without writing the result to the corresponding value register.

The SMBus is still enabled. Power consumption in the standby mode is reduced to less than 10 μA if there is no SMBus activity, or 100 μA if there are clock and data signals on the bus.

When the device is in standby mode, it is still possible to initiate a one-shot conversion of both channels by writing XXh to the One-Shot Register (address 0Fh), after which the device will return to standby. It is also possible to write new values to the limit register while it is in standby. If the values stored in the temperature value registers are now outside the new limits, an $\overline{\text{ALERT}}$ is generated even though the ADM1032 is still in standby.

THE ADM1032 INTERRUPT SYSTEM

The ADM1032 has two interrupt outputs, $\overline{\text{ALERT}}$ and $\overline{\text{THERM}}$. These have different functions. $\overline{\text{ALERT}}$ responds to violations of software-programmed temperature limits and is maskable. $\overline{\text{THERM}}$ is intended as a "fail-safe" interrupt output that cannot be masked.

If the temperature goes equal to or below the lower temperature limit, the $\overline{\text{ALERT}}$ pin will be asserted low to indicate an out-of-limit condition. If the temperature is within the programmed low and high temperature limits, no interrupt will be generated.

If the temperature exceeds the high temperature limit, the $\overline{\text{ALERT}}$ pin will be asserted low to indicate an over temperature condition. A local and remote $\overline{\text{THERM}}$ limit, may be programmed into the device to set the temperature limit above which the over temperature $\overline{\text{THERM}}$ pin will be asserted low. This temperature limit should be equal to or greater than the high temperature limit programmed.

The behavior of the high limit and $\overline{\text{THERM}}$ limit is as follows:

1. If either temperature measured exceeds the high temperature limit, the $\overline{\text{ALERT}}$ output will assert low.
2. If the local or remote temperature continues to increase and either one exceeds the $\overline{\text{THERM}}$ limit, the $\overline{\text{THERM}}$ output asserts low. This can be used to throttle the CPU clock or switch on a fan.

A $\overline{\text{THERM}}$ Hysteresis Value is provided to prevent a cooling fan cycling on and off. The power-on default value is 10°C but this may be reprogrammed to any value after power-up. This hysteresis value applies to both the local and remote channels

Using these two limits in this way allows the user to gain maximum performance from the system by only slowing it down, should it be at a critical temperature.

The $\overline{\text{THERM}}$ signal is open drain and requires a pull-up to V_{DD} . The $\overline{\text{THERM}}$ signal must always be pulled up to the same power supply as the ADM1032, unlike the SMBus signals (SDATA, SCLK, and $\overline{\text{ALERT}}$) which may be pulled to a different power rail, usually that of the SMBus controller.

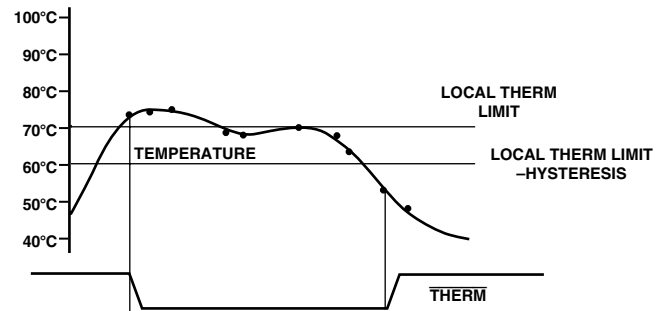

Figure 5. Operation of the $\overline{\text{THERM}}$ Output

Table IX. $\overline{\text{THERM}}$ HYSTERESIS Sample Values

$\overline{\text{THERM}}$ HYSTERESIS	Binary Representation
0°C	0 000 0000
1°C	0 000 0001
10°C	0 000 1010

SENSOR FAULT DETECTION

At the D+ input the ADM1032 has a fault detector that detects if the external sensor diode is open-circuited. This is a simple voltage comparator that trips if the voltage at D+ exceeds $V_{\text{DD}} - 1\text{V}$ (typical). The output of this comparator is checked when a conversion is initiated, and sets Bit 2 of the Status Register if a fault is detected.

If the remote sensor voltage falls below the normal measuring range, for example due to the diode being short-circuited, the ADC will output -128 (1000 0000). Since the normal operating temperature range of the device only extends down to 0°C, this output code should never be seen in normal operation, so it can be interpreted as a fault condition. Since it will be outside the power-on default low temperature limit (0°C) and any low limit that would normally be programmed, a short-circuit sensor will cause an SMBus alert.

In this respect the ADM1032 differs from and improves upon, competitive devices that output zero if the external sensor goes short-circuit. These devices can misinterpret a genuine 0°C measurement as a fault condition.

When the D+ and D- lines are shorted together, an $\overline{\text{ALERT}}$ will always be generated. This is because the remote value register reports a temperature value of -128°C. Since the ADM1032 performs a less-than or equal-to comparison with the low limit, an $\overline{\text{ALERT}}$ is generated even when the low limit is set to its minimum of -128°C.

APPLICATIONS INFORMATION

FACTORS AFFECTING ACCURACY

Remote Sensing Diode

The ADM1032 is designed to work with substrate transistors built into processors' CPUs or with discrete transistors. Substrate transistors will generally be PNP types with the collector connected to the substrate. Discrete types can be either PNP or NPN transistor connected as a diode (base shorted to collector). If an NPN transistor is used, the collector and base are connected to D+ and the emitter to D-. If a PNP transistor is used, the collector and base are connected to D- and the emitter to D+. Substrate transistors are found in a number of CPUs. To reduce the error due to variations in these substrate and discrete transistors, a number of factors should be taken into consideration:

1. The ideality factor, n_f , of the transistor. The ideality factor is a measure of the deviation of the thermal diode from ideal behavior. The ADM1032 is trimmed for an n_f value of 1.008. The following equation may be used to calculate the error introduced at a temperature $T^\circ\text{C}$ when using a transistor whose n_f does not equal 1.008. Consult the processor datasheet for n_f values.

$$\Delta T = \frac{(n_{\text{natural}} - 1.008)}{1.008} \times (273.15 \text{ Kelvin} + T)$$

This value can be written to the offset register and is automatically added to or subtracted from the temperature measurement.

2. Some CPU manufacturers specify the high and low current levels of the substrate transistors. The high current level of the ADM1032, I_{HIGH} , is 230 μA and the low level current, I_{LOW} , is 13 μA . If the ADM1032 current levels do not match the levels of the CPU manufacturers, then it may become necessary to remove an offset. The CPU's datasheet will advise whether this offset needs to be removed and how to calculate it. This offset may be programmed to the offset register. It is important to note that if accounting for two or more offsets is needed, then the algebraic sum of these offsets must be programmed to the Offset Register.

If a discrete transistor is being used with the ADM1032 the best accuracy will be obtained by choosing devices according to the following criteria:

- Base-emitter voltage greater than 0.25 V at 6 mA, at the highest operating temperature.
- Base-emitter voltage less than 0.95 V at 100 mA, at the lowest operating temperature.
- Base resistance less than 100 Ω .
- Small variation in h_{FE} (say 50 to 150) that indicates tight control of V_{BE} characteristics.

Transistors such as 2N3904, 2N3906, or equivalents in SOT-23 packages are suitable devices to use.

THERMAL INERTIA AND SELF-HEATING

Accuracy depends on the temperature of the remote-sensing diode and/or the internal temperature sensor being at the same temperature as that being measured, and a number of factors can affect this. Ideally, the sensor should be in good thermal contact with the part of the system being measured, for example the processor. If it is not, the thermal inertia caused by the mass of the sensor will cause a lag in the response of the sensor to a

temperature change. In the case of the remote sensor this should not be a problem, as it will either be a substrate transistor in the processor, or can be a small package device such as SOT-23 placed in close proximity to it.

The on-chip sensor, however, will often be remote from the processor, and will only be monitoring the general ambient temperature around the package. The thermal time constant of the SO-8 package in still air is about 140 seconds, and if the ambient air temperature quickly changed by 100 degrees, it would take about 12 minutes (5 time constants) for the junction temperature of the ADM1032 to settle within 1 degree of this. In practice, the ADM1032 package will be in electrical, and hence thermal, contact with a printed circuit board, and may also be in a forced airflow. How accurately the temperature of the board and/or the forced airflow reflect the temperature to be measured will also affect the accuracy.

Self-heating due to the power dissipated in the ADM1032 or the remote sensor, causes the chip temperature of the device or remote sensor to rise above ambient. However, the current forced through the remote sensor is so small that self-heating is negligible. In the case of the ADM1032, the worst-case condition occurs when the device is converting at 16 conversions per second while sinking the maximum current of 1 mA at the ALERT and THERM output. In this case, the total power dissipation in the device is about 11 mW. The thermal resistance, θ_{JA} , of the SO-8 package is about 121 $^\circ\text{C}/\text{W}$.

In practice, the package will have electrical and hence thermal connection to the printed circuit board, so the temperature rise due to self-heating will be negligible.

LAYOUT CONSIDERATIONS

Digital boards can be electrically noisy environments, and the ADM1032 is measuring very small voltages from the remote sensor, so care must be taken to minimize noise induced at the sensor inputs. The following precautions should be taken:

1. Place the ADM1032 as close as possible to the remote sensing diode. Provided that the worst noise sources, i.e., clock generators, data/address buses, and CRTs, are avoided, this distance can be 4 to 8 inches.
2. Route the D+ and D- tracks close together, in parallel, with grounded guard tracks on each side. Provide a ground plane under the tracks if possible.
3. Use wide tracks to minimize inductance and reduce noise pickup. 10 mil track minimum width and spacing is recommended.



Figure 6. Arrangement of Signal Tracks

4. Try to minimize the number of copper/solder joints, which can cause thermocouple effects. Where copper/solder joints are used, make sure that they are in both the D+ and D- path and at the same temperature.

ADM1032

Thermocouple effects should not be a major problem as 1°C corresponds to about 200 μV, and thermocouple voltages are about 3 μV/°C of temperature difference. Unless there are two thermocouples with a big temperature differential between them, thermocouple voltages should be much less than 200 μV.

- Place a 0.1 μF bypass capacitor close to the V_{DD} pin. In very noisy environments place a 2200 pF input filter capacitors across D+, D- close to the ADM1032.
- If the distance to the remote sensor is more than 8 inches, the use of twisted pair cable is recommended. This will work up to about 6 to 12 feet.
- For really long distances (up to 100 feet) use shielded twisted pair such as Belden #8451 microphone cable. Connect the twisted pair to D+ and D- and the shield to GND close to the ADM1032. Leave the remote end of the shield unconnected to avoid ground loops.

Because the measurement technique uses switched current sources, excessive cable and/or filter capacitance can affect the measurement. When using long cables, the filter capacitor may be reduced or removed.

Cable resistance can also introduce errors. 1 Ω series resistance introduces about 1°C error.

APPLICATION CIRCUIT

Figure 7 shows a typical application circuit for the ADM1032, using a discrete sensor transistor connected via a shielded, twisted pair cable. The pull-ups on SCLK, SDATA, and ALERT are required only if they are not already provided elsewhere in the system.

The SCLK, and SDATA pins of the ADM1032 can be interfaced directly to the SMBus of an I/O controller such as the Intel 820 chipset.

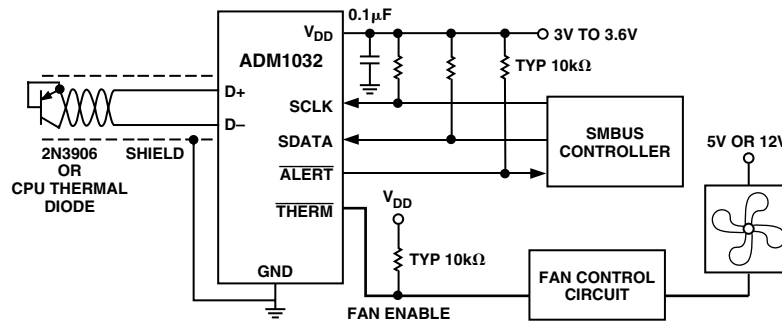
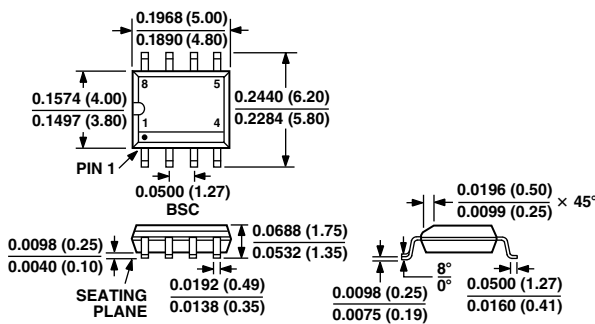

Figure 7. Typical Application Circuit

OUTLINE DIMENSIONS

Dimensions shown in inches and (mm).

8-Lead SO (R-8)



8-Lead Micro_SO (RM-8)

